

**Firestone**

Airstroke® actuators/Airmount® isolators

# AIRSTROKE®

ACTUATORS



# AIRMOUNT®

ISOLATORS



## Engineering Manual & Design Guide

**Firestone**

World's Number 1   
Air Spring.

FIRESTONE INDUSTRIAL PRODUCTS COMPANY

# TABLE OF CONTENTS

<b>Table of Contents and Introduction</b> .....	2	<b>Airmount Vibration Isolation</b>	
<b>Advantages of Airstroke Actuators</b> .....	3	Selection Procedure and Isolation Formula .....	21-22
<b>Advantages of Airmount Isolators</b> .....	4	Dynamic Spring Rate Formula .....	22
<b>Air Spring Bellows Construction</b> .....	5	Natural Frequency Formula .....	22
<b>End Closure Options</b>		Center of Gravity .....	23
Crimped bead plates .....	6	Lateral Rates and Stability .....	23
Crimped bead plates mounting hardware .....	7	Triple Convuluted and Reversible	
Steel bead rings .....	8	Sleeve Type Parts .....	24
Aluminum bead rings .....	9	Design Envelope .....	24
The four types of bead rings and		Safety Stops .....	24
mounting hardware .....	10	Initial Installation .....	24
Rolled plates .....	11	Startup and Shutdown/Resonance	
<b>How to use the Static Data Chart</b>		and Amplification .....	24
For Airstroke Actuation .....	12&13	Isolating an Unbalanced Mass .....	24
For Airmount Isolation .....	13	Low Pressure Operation .....	24
<b>Internal Rubber Bumpers</b> .....	13	Effect of an Auxiliary Reservoir .....	24
<b>Basic Parameters Applicable to Both Airstroke</b>		Damping .....	25
<b>Actuators and Airmount Isolators</b>		Plumbing Systems .....	25
Media .....	14	Isolation Chart .....	26
Pressure .....	14	Airmount Isolation Problem Solvers .....	27-28
Temperature .....	14	<b>Miscellaneous Applications</b>	
Contaminants .....	14	Shock Impact Isolation .....	29
Storage .....	14	Protective Boot and Flexible Connector .....	29
<b>Airstroke Actuation</b>		Vacuum Pump .....	29
Selection .....	15	Inflatable Chuck .....	29
Down and Up Stops .....	15	Cam Follower .....	29
Return .....	15	Miscellaneous Problem Solvers .....	30-31
Guiding .....	15	<b>Airstroke/Airmount Selection Guide</b> .....	32-33
Angular Capability .....	15	<b>Individual Air Spring Data Pages</b> .....	34-98
Horizontal Misalignment .....	16	<b>Index &amp; Work Sheets</b>	
Design Envelope .....	16	Order Number to Style Number	
Stacking .....	16	to Page Number .....	100-101
Fail-Safe Devices .....	16	Airstroke Design Parameter Worksheet .....	103
Vacuum .....	16	Airmount Design Parameter Worksheet .....	105
Inflation Pressure Chart .....	17	Style Number to Page Number .....	107
Airstroke Actuator Problem Solvers .....	18,19 & 20		

## INTRODUCTION

Firestone developed the air spring in the late 1930's as a more efficient spring (vibration isolator) for use in vehicle suspensions. Airide® springs, as they were named, provided the means for a suspension to reduce the amount of road shock and vibration transmitted into the vehicle. Millions of miles of actual use have proven the dependability and effectiveness of the air suspension concept using Airide® springs by Firestone.

Airstroke® actuators, Airmount® isolators, and Airide® springs are Firestone registered trademark names *for one product*: the air spring. The use of the air spring (actuator, industrial isolator and vehicular isolator, respectively) determines which name is applied to it. All of the parts in this catalogue may be used as Airstroke actuators (except the 1X84D-1 and 2M1A) or Airmount isolators, with two exceptions: Triple convuluted and reversible sleeve type air springs (except the 1M1A-0) should not be used as Airmount isolators without consulting Firestone.

Individual Airstroke actuators and Airmount isolators are capable of generating a force or supporting a load of up to 100,000 pounds, and a stroke capability of up to 14 inches is possible. Included in this engineering manual are detailed operating characteristics for many of the standard Firestone air springs, along with technical details and procedures for using these products.

### PLEASE NOTE:

The information contained in this publication is intended to provide a general guide to the characteristics and applications of these products. The material, herein, was developed through engineering design and development, testing and actual applications and is believed to be reliable and accurate. Firestone, however, makes no warranty, express or implied, of this information. Anyone making use of this material does so at his own risk and assumes all liability resulting from such use. It is suggested that competent professional assistance be employed for specific applications.

# ADVANTAGES OF FIRESTONE AIRSTROKE® ACTUATORS

*Why use an Airstroke actuator (rather than air or hydraulic cylinder) for actuation?*

## **LOW COST**

Generally, initial cost is one-half or less than conventional pneumatic or hydraulic cylinders of the same force capabilities. This initial cost advantage is many times greater in the larger sizes.

## **WIDE SIZE RANGE**

Airstroke actuators are available in sizes ranging from 2.2 inches to 37 inches in diameter. The force capability is 100,000 pounds. Strokes of up to 14 inches are possible.

## **DURABLE FOR LONG LIFE**

Airstroke actuators are a further application of Firestone's time proven Airide springs for truck and bus suspensions. The long life and durability necessary for millions of miles of heavy duty suspension use under adverse environmental conditions are also important factors in machine design.

## **NO MAINTENANCE OR LUBRICATION REQUIRED**

## **NO INTERNAL ROD OR PISTON**

Airstroke actuators have no internal rod, piston, or sliding seals as do conventional cylinders. This allows for the design of Airstroke actuators into applications where dirt or grit would destroy the seals on conventional cylinders.

## **FRICTION FREE FOR IMMEDIATE RESPONSE**

Since Airstroke actuators have no sliding seals, there is no breakaway friction as with conventional cylinders

## **FLEXIBLE MEDIA**

An Airstroke actuator can do its work with either a liquid or gas (Please see page 14 for acceptable media choices.)

## **ANGULAR CAPABILITY**

An Airstroke possesses the unique capability of stroking through an arc without a clevis. Angular motion of up to 30 degrees is possible, along with the design advantage of generally less complex linkages.

## **SIDE LOADING CAPABILITY**

Airstroke actuators, within certain limits, are not affected by side loads as are conventional cylinders. This misalignment capability eliminates potential rod bending, scoring, and excessive seal wear common to conventional cylinders.

## **COMPACT STARTING HEIGHT**

Airstroke actuators have a low profile compared to conventional cylinders. Our smallest Airstroke actuator (2.2 inch/dia.) collapses to just 1.1 inches in height, while our largest triple convoluted Airstroke (37 inch/dia.) will collapse to a very compact 5.5 inches.

## **FACTORY SEALED AND TESTED**

Most Airstroke actuators feature Firestone's proven concept of crimped end plates. The crimped design allows for preshipment testing and quicker installation on equipment.

PLEASE REFER TO PAGE 15 FOR A THOROUGH DISCUSSION OF ACTUATION.

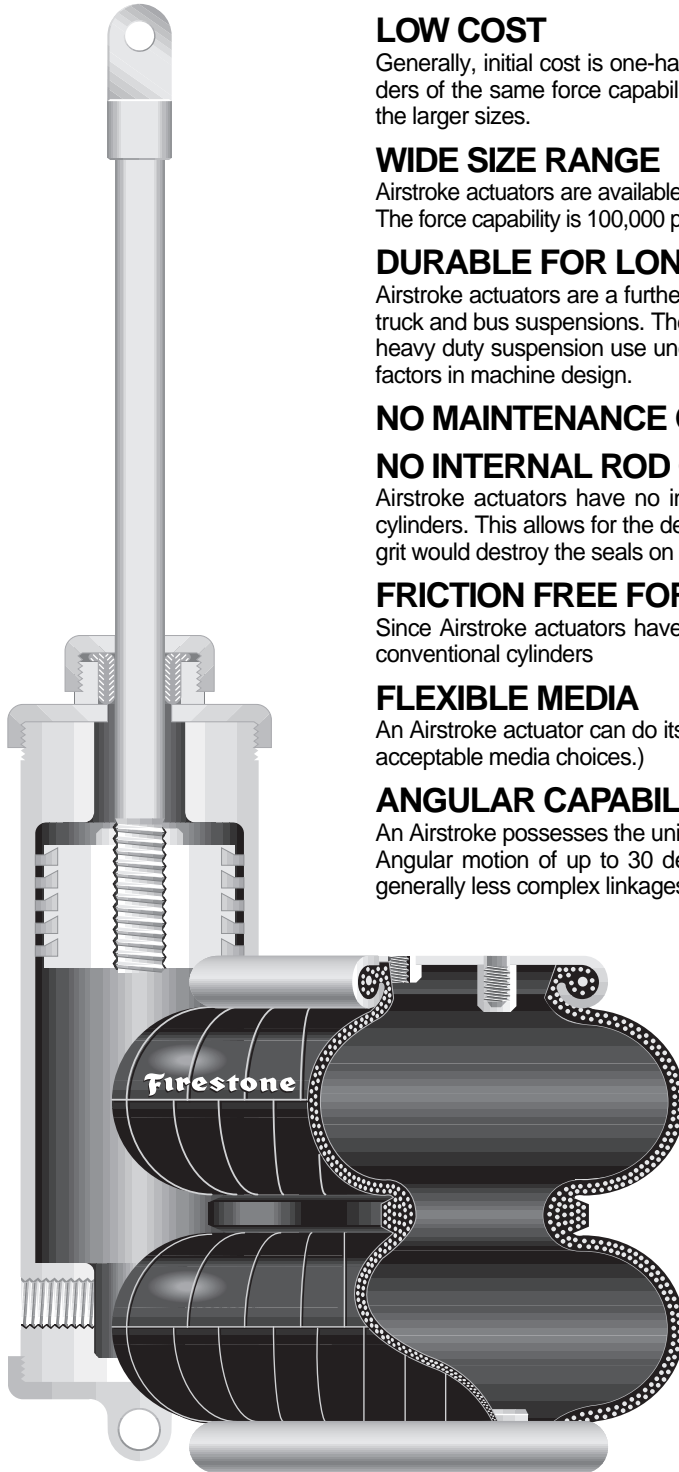

# ADVANTAGES OF FIRESTONE AIRMOUNT® ISOLATORS

*Why use an Airmount isolator rather than a coil spring or other type of isolator?*

## **UNSURPASSED ISOLATION CAPABILITY**

Airmount isolators can provide the highest degree of isolation of any type vibration isolator. System natural frequencies as low as 60 cycles per minute (1 Hertz) are available. The addition of an auxiliary reservoir can provide even lower system frequencies. In order to achieve similar results from a conventional coil spring isolator, a real deflection of 9 inches would be required.

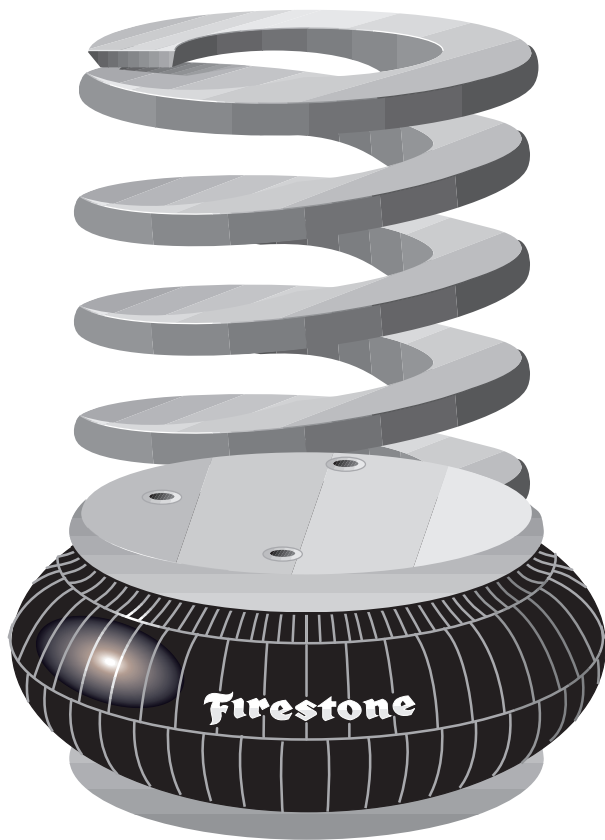

## **CONSTANT ISOLATION EFFICIENCY**

Airmount isolators are unique in that the system's natural frequency does not change significantly with changes in load. This unique feature, combined with accurate height control, will allow the use of the same Airmount isolator at each mounting point of an unevenly loaded machine.

## **ACCURATE HEIGHT CONTROL**

Airmount isolators provide accurate height control through regulation of internal air pressure. This feature eliminates the fatigue and permanent set found in the use of other types of vibration isolators.

## **WIDE SIZE RANGE**

Airmount isolators are capable of isolating loads of 100 pounds per mounting point to over 100,000 pounds per mounting point.

## **COMPACT INSTALLED HEIGHT**

Airmount isolators can carry the loads and provide the isolation described above at installed heights as low as 2.5 inches. Coil springs providing equal isolation would require a free height of 5 to 25 inches.

## **EXTENDED EQUIPMENT LIFE**

Airmount isolators extend equipment life through their superior isolation capabilities.

## **EFFECTIVE NOISE REDUCTION**

Airmount isolators reduce structurally transmitted noise. Airmount isolators are also quiet in themselves, since there is no spring chatter as found in conventional coil springs.

## **VERSATILE**

Airmount isolators can be used not only to protect structural members from vibrating machinery, but are also widely used to protect delicate equipment from structurally transmitted vibration.

PLEASE REFER TO PAGE 21 FOR A THOROUGH DISCUSSION OF VIBRATION ISOLATION.

# AIR SPRING BELLOWS CONSTRUCTION

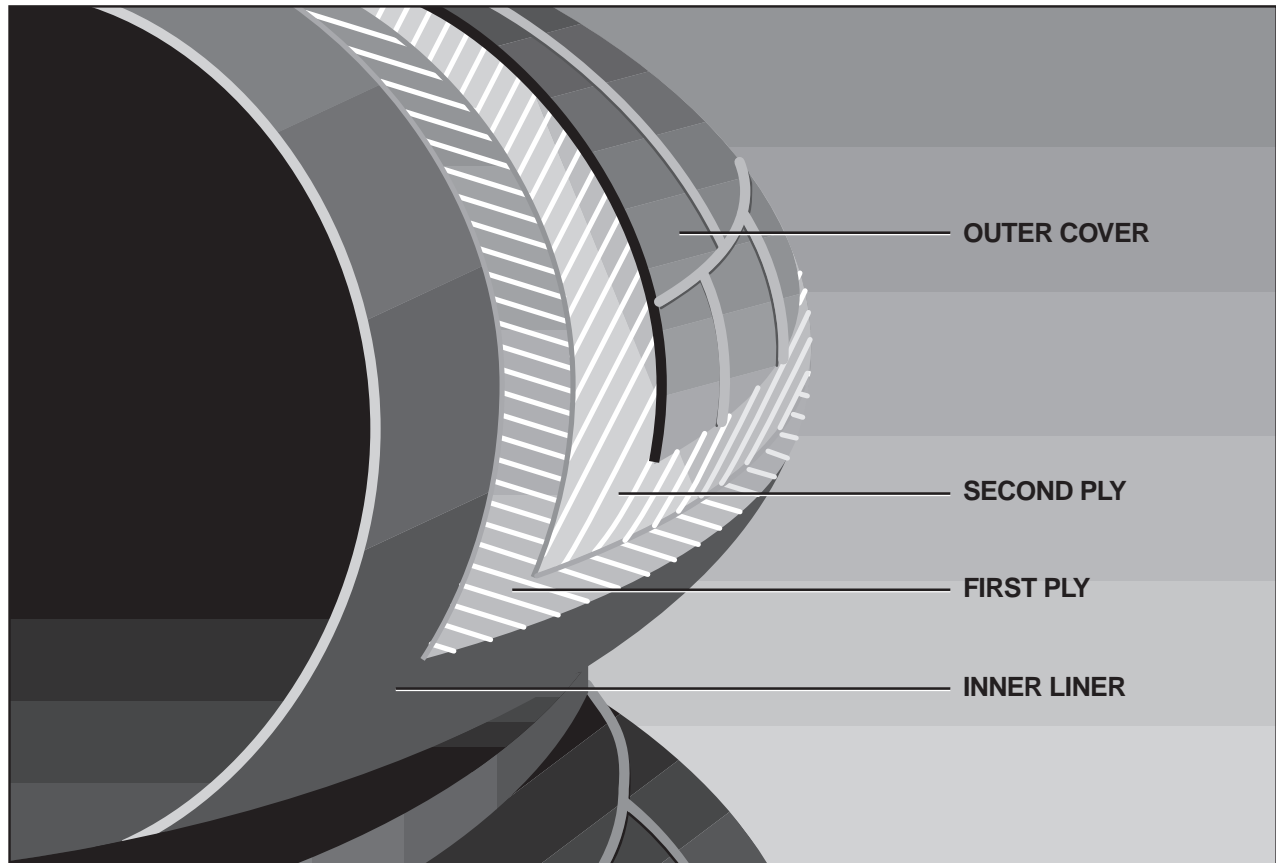

An air spring is a carefully designed rubber/fabric bellows which contains a column of compressed air. The rubber bellows itself does not provide force or support load. This is done by the column of air.

Firestone air springs are highly engineered elastomeric bellows with specially designed metal end closures. Our standard two ply air spring bellows is actually made up of four layers:

- a. An inner liner of calendered rubber.
- b. One ply of fabric reinforced rubber.
- c. A second ply of fabric-reinforced rubber (with the cords at a specific bias angle to the first ply).
- d. An outer cover of calendered rubber.

Many of our air springs are also available in high strength construction for higher pressures (see page 14 for more detailed information). In this case, there are four plies of fabric-reinforced rubber, with an inner liner and outer cover.

The two ply air spring is standard. Where high strength construction is available, it is so noted in the selection guide (page 32), on the individual Data sheets, and in the index (page 107). If the high strength style number is omitted, then it is not currently available in that particular part.

Each air spring bellows is identified by a style number. This style number is molded into the bellows during the curing (or vulcanization) process. Examples would be 16, 22, 313, 1T15M-6, etc... This identifies *only* the rubber/fabric bellows and *not the complete assembly*. There are several different end closure options available for most air springs; therefore, please always specify both the style number and the complete **assembly order number (AON)**. An example would be: Style #22, assembly order number W01-M58-6180. Both numbers are given on the individual data sheets.

# END CLOSURE OPTIONS

Each individual air spring data sheet shows a cross sectional view of the most popular end closure option for that part. For convoluted air springs 16 inches in diameter and less, and for the reversible sleeve air springs, the *Crimped Bead Plate*

*attachment is shown.* For convoluted air springs 17 inches in diameter and larger, a *Bead Ring attachment is shown.* An air spring of each variety, with proper terminology for each, is shown on the following pages.

## CRIMPED BEAD PLATES

### CONVOLUTED AIR SPRINGS

(#22 is shown)

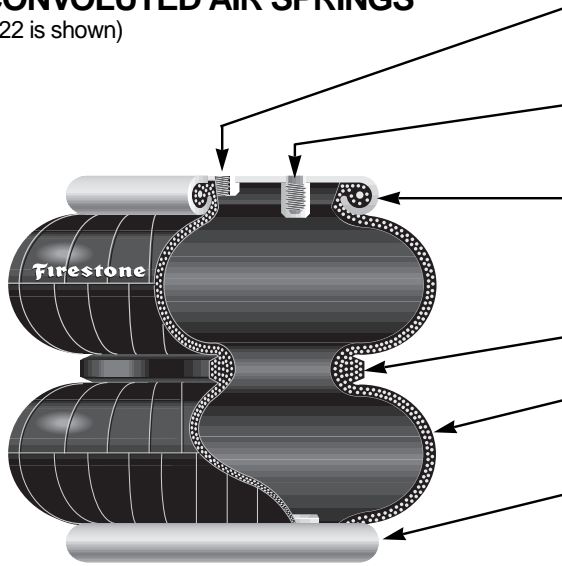

#### AIR INLET

1/4" NPT is standard. 3/4" NPT is also available for most parts. (See the data sheet order block on each specific part).

#### BLIND NUT

3/8-16 UNC thread x 5/8" deep (two or four per each plate depending on part size). Used for mounting the part.

#### UPPER BEAD PLATE

(9 gauge carbon steel, .149"). Permanently crimped to bellows to form an airtight assembly which allows for leak testing before the unit leaves the factory. Zinc/chromate plated for rust protection.

#### GIRDLE HOOP

Wire wound type shown, molded into the bellows.

#### BELLOWS

Wall gauge is approximately 1/4". See page 5 for detailed information.

#### LOWER BEAD PLATE

Usually the same as upper bead plate, except without air inlet.

### REVERSIBLE SLEEVE AIR SPRINGS

(1T15M-6 is shown)

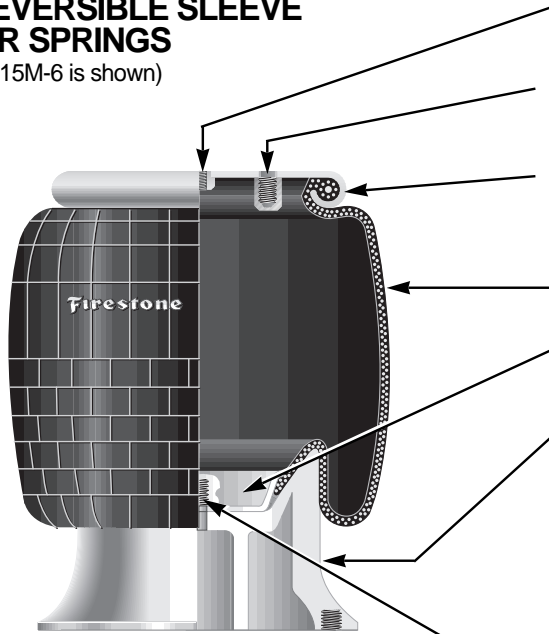

**AIR INLET** 1/4" NPT is standard. 3/4" NPT is also available for most parts. (See the data sheet order block on each specific part).

**BLIND NUT** 3/8-16 UNC thread x 5/8" deep (two or four per each plate depending on part size). Used for mounting the part.

**BEAD PLATE** (9 gauge carbon steel, .149"). Permanently crimped to bellows to form an airtight assembly which allows for leak testing before the unit leaves the factory. Zinc/chromate plated for rust protection.

**BELLOWS** Wall gauge is approximately 1/4". See page 5 for detailed information.

**BELLOWS END CLOSURE**—(steel) Permanently molded into the bellows (Except for styles 1T19L-7, 1T19L-11).

**PISTON** May be made of aluminum, steel, plastic or hard rubber. Held to the bellows by a bolt which screws into the bumper stud. For mounting, a long bolt may be used coming up through the mounting surface. Or, a short bolt may be used to attach the piston to the lower end closure and then use the threaded holes in the piston to secure the assembly to the mounting surface. (A piston long bolt is usually not included).

**BUMPER STUD** A permanent part of the bellows end closure (and bellows). It has two functions:

1. The optional rubber bumper snaps over the outside.
2. The inside is a threaded hole (see data sheets for thread dimension and depth) used to secure the piston to the bellows.

**THREADED HOLE** May be used for attachment to mounting surface. Not included in some pistons (See individual data sheets for specific part configuration.)

# CRIMPED BEAD PLATE MOUNTING HARDWARE

**CRIMPED BEAD PLATE AIR SPRINGS** Use the blind nuts for attachment. This is accomplished by bringing bolts (two or four depending upon air spring size) through the

customer supplied mounting plate and tightening into the blind nut. If this bolt is too long, it may fracture the bottom out of the blind nut.

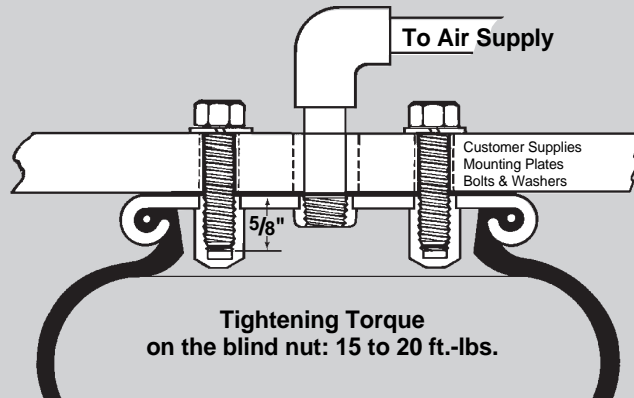
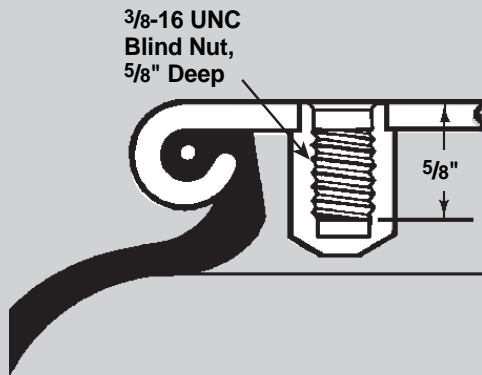

## STUD ADAPTER

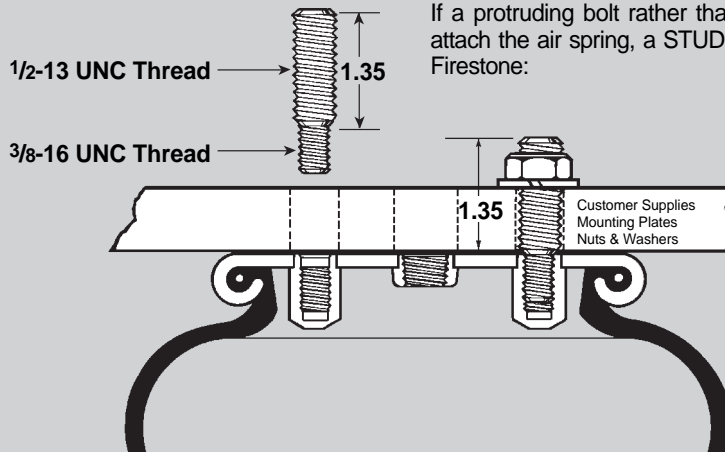

If a protruding bolt rather than a blind nut is preferred to attach the air spring, a STUD ADAPTER is available from Firestone:

**TANK VALVE** One method for inflating air springs (primarily used in Airmount isolator applications) is with a tank valve: An air hose chuck is used (as inflating a

tire with an air line). Care must be taken to periodically check the pressure within the air spring, because air will slowly permeate through the rubber/fabric bellows (See page 25).

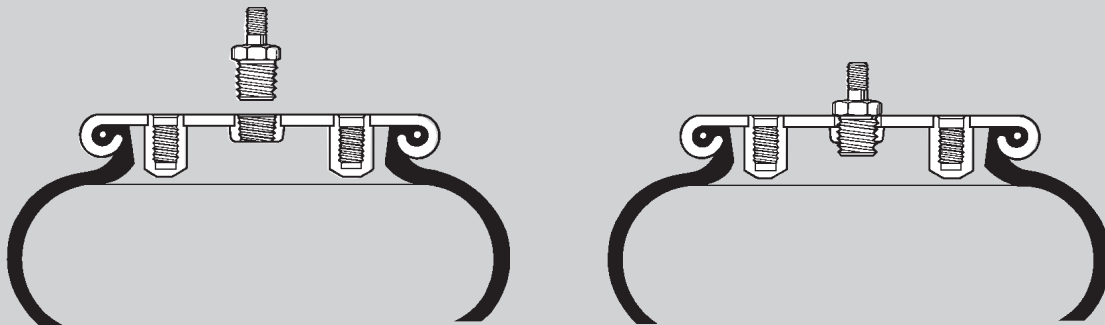

# END CLOSURE OPTIONS

## STEEL BEAD RINGS

### CONVOLUTED AIR SPRINGS

(#22 is shown, with bead rings instead of crimped bead plates)

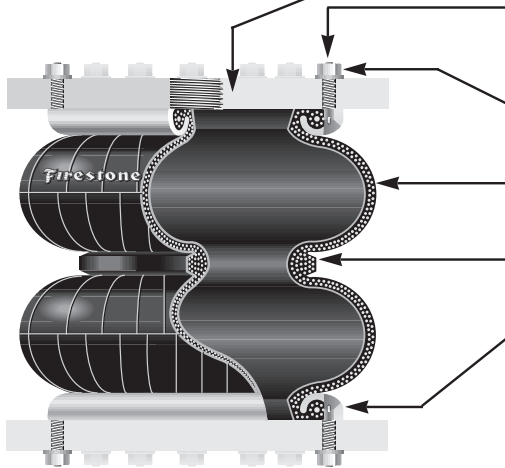

**MOUNTING PLATE** is not included. See page 10 for material, machining recommendations, and installation instructions.

**BEAD RING BOLT** May be one of four varieties. See page 10. Also refer to the data sheet order block on each individual part for bolt lengths.

**NUTS AND LOCKWASHERS** are included with the part. (Except for socket head type bead rings).

**BELLOWS** Wall gauge is approximately 1/4". See page 5 for detailed information.

**GIRDLE HOOP** Wire wound type shown, molded into the bellows.

**BEAD RING**, upper and lower. Countersunk steel type shown. May also be of a second stamped steel variety or made of aluminum. See page 10. Also refer to the data sheet order block on each part for type and material. See the selection guide on page 32 for bolt circle diameter and number of bolts (each ring).

### REVERSIBLE SLEEVE AIR SPRINGS

(1T15M-6 is shown, with a bead ring instead of a crimped bead plate)

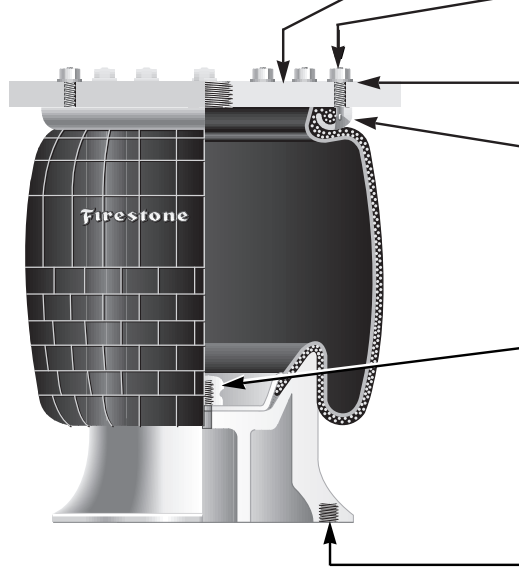

**MOUNTING PLATE** is not included. See page 10 for material, machining recommendations, and installation instructions.

**BEAD RING BOLT** May be one of four varieties. See below. Also refer to the data sheet order block on each individual part for bolt lengths.

**NUTS AND LOCKWASHERS** are included with the part. (Except for socket head type bead rings).

**BEAD RING** Countersunk steel type shown. See the selection guide on page 32 for bolt circle diameter and number of bolts (each ring).

**BUMPER STUD** A permanent part of the bellows end closure (and bellows). It has two functions:

1. The optional rubber bumper snaps over the outside (of it).
2. The inside is a threaded hole (see data sheets for thread dimension and depth) used to secure the piston to the bellows.

**THREADED HOLE** May be used for attachment to mounting surface. Not included in some pistons (See individual data sheets for specific part configuration.)



# END CLOSURE OPTIONS

## LARGE PARTS WITH ALUMINUM BEAD RINGS

All of the parts that are shown with crimped bead plates are also available with bead rings. (Bead plates are not suitable for some applications.) Typical examples of where bead rings are often used follow:

1. Where parts are stacked to increase stroke (See page 16).
2. Where the air spring is being used as a boot or flexible connector (See page 29).
3. When used as an Airmount isolator with an auxiliary reservoir (See page 24).
4. When air must move in or out of the unit at an extremely fast rate (and a 3/4" NPT air inlet is too small).
5. When used with an internal shaft, to either guide the part or to pull (rather than push) a load.

## CONVOLUTED AIR SPRINGS

(#203 is shown)

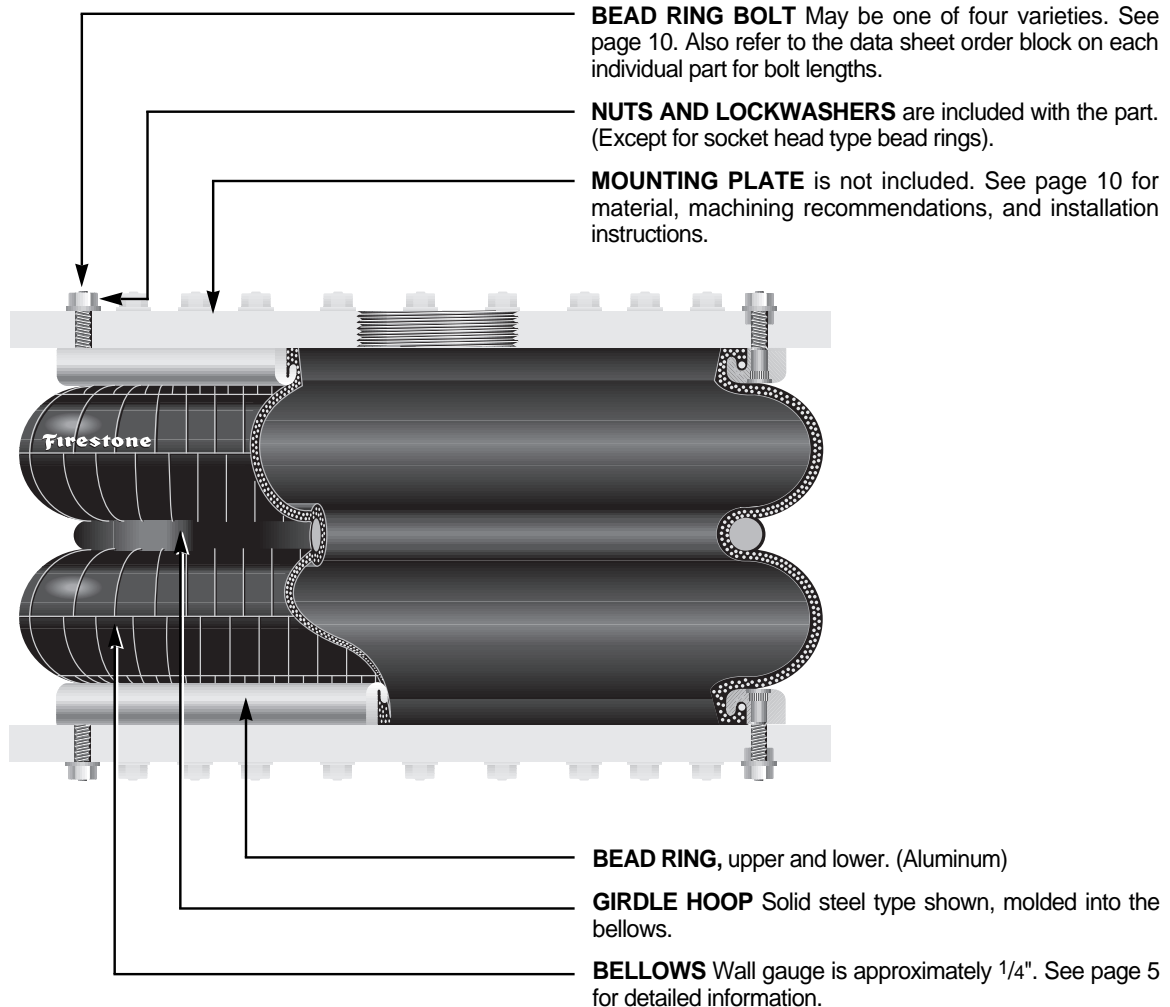

# END CLOSURE OPTIONS

## THE FOUR TYPES OF BEAD RINGS

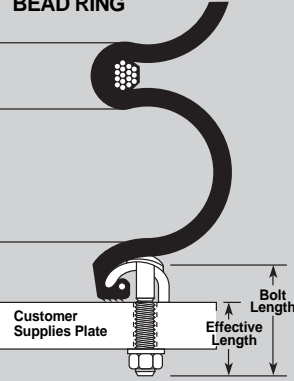
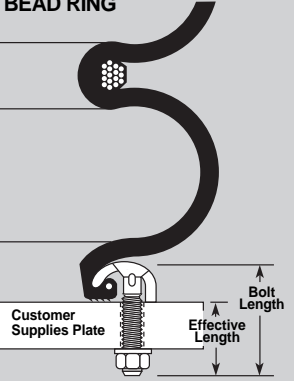
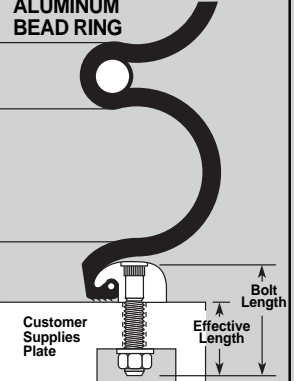
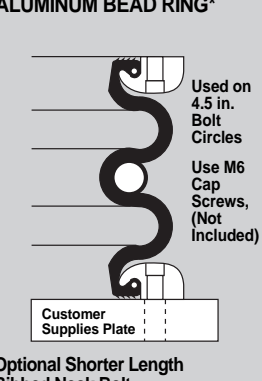
BUTTON HEAD STEEL BEAD RING	COUNTERSUNK STEEL BEAD RING	RIBBED NECK ALUMINUM BEAD RING	SOCKET HEAD ALUMINUM BEAD RING*
			
<b>Standard Bolt Length (in.)</b> 1 7/8	<b>Standard Bolt Length (in.)</b> 1 5/8	<b>Standard Bolt Length (in.)</b> 1 7/8	
<b>Standard Effective Length (in.)</b> 1.28	<b>Standard Effective Length (in.)</b> 1.22	<b>Standard Effective Length (in.)</b> 1.28	
<b>Standard Order Number (bolt only)</b> WC1-358-3607	<b>Standard Order Number (bolt only)</b> WC1-358-3625	<b>Standard Order Number (bolt only)</b> WC1-358-3620	
<b>Thread</b> 5/16-24 UNF	<b>Thread</b> 5/16-24 UNF	<b>Thread</b> 3/8-24 UNF	
<b>Tightening Torque (ft.-lbs.)</b> 17 to 22	<b>Tightening Torque (ft.-lbs.)</b> 17 to 22	<b>Tightening Torque (ft.-lbs.)</b> 28 to 32	

## BEAD RINGS CONTINUED

When using bead rings, THE CUSTOMER WILL NEED TO FABRICATE HIS OWN MOUNTING PLATES. Hot or cold rolled steel provides satisfactory mounting surfaces, with specific finishes of 32 micro-inches, if machined in a circular fashion, and 250 micro-inches when ground (side to side). The thickness of mounting plates depends upon the application. The plates must be strong enough and backed by structural members to prevent bowing (of the plates) when subjected to the forces or loads involved. The rubber bellows provides its own seal; therefore, 'O' rings or other sealants are not needed when installing the part.

### INSTALLATION

Follow this technique for assembling a bead ring style bellows to the mounting plate:

- Insert the bolts into the bead ring (the bead rings have been previously attached to the bellows at the factory). The bolts will be pulled into place by the action of tightening the nuts.
- Slip all of the bolts (which are protruding through the bead ring) into the mating holes of the mounting plate and attach the lockwashers and nuts. FINGER TIGHTEN all nuts to produce a uniform gap between the bead ring and mounting plate all the way around.

- At this point, make certain that the bellows bead is properly seated under the bead ring.

PLEASE NOTE THAT UNIFORM SUCCESSIVE TIGHTENING OF THE NUTS IS IMPORTANT TO SEAT THE RUBBER BEAD PROPERLY TO THE MOUNTING PLATE FOR ITS FULL CIRCUMFERENCE.

Continue with the following sequence:

- Tighten all nuts one turn each, moving around the circle until continuous contact is made between the bead ring and mounting plate.
- Torque all nuts to the torque specifications shown on the page, going at least two complete turns around the bolt circle.

### MATERIAL

Bead rings are supplied in either steel or aluminum. Steel bead rings can be of two different types. Both the bead ring material and type of ring are called out in the description section of the order block on each individual data page. Also, the bolt length (for the bolts supplied with that particular order number) is given.

WHERE A BEAD PLATE PART IS SHOWN AND THE BEAD RING ATTACHMENT IS PREFERRED, PLEASE REFER TO THE SELECTION GUIDE ON PAGE 32 FOR BOLT CIRCLE DIAMETERS AND NUMBER OF BOLTS (EACH RING).

# END CLOSURE OPTIONS

## LARGE PARTS WITH ROLLED PLATES

### LARGE CONVOLUTED AIR SPRINGS

(#203 is shown, with rolled plates instead of bead rings)

The convoluted parts, with 17, 20, and 22 inch diameter, are shown with bead rings as standard. We have developed a method for permanently attaching plates to these larger sized Airstrokes (called rolled plate assembly). These parts may be an advantage over the bead ring parts in some cases, because installation is much easier (they attach the same way as the bead plate parts). When installing the rolled plate parts, a backup plate as large in diameter as the bead plate must be used. This plate should be a minimum of 1/2 inch thick.

Again, for the blind nut and air entrance locations of rolled plate parts (bead rings are shown as standard on the data pages), please refer to the selection guide on page 32. The static data chart on each individual part may be used for the rolled plate version; but, two modifications must be made:

1. Increase the minimum height by .70 inch.
2. Add .70 inch to the height (bottom axis) before reading loads.

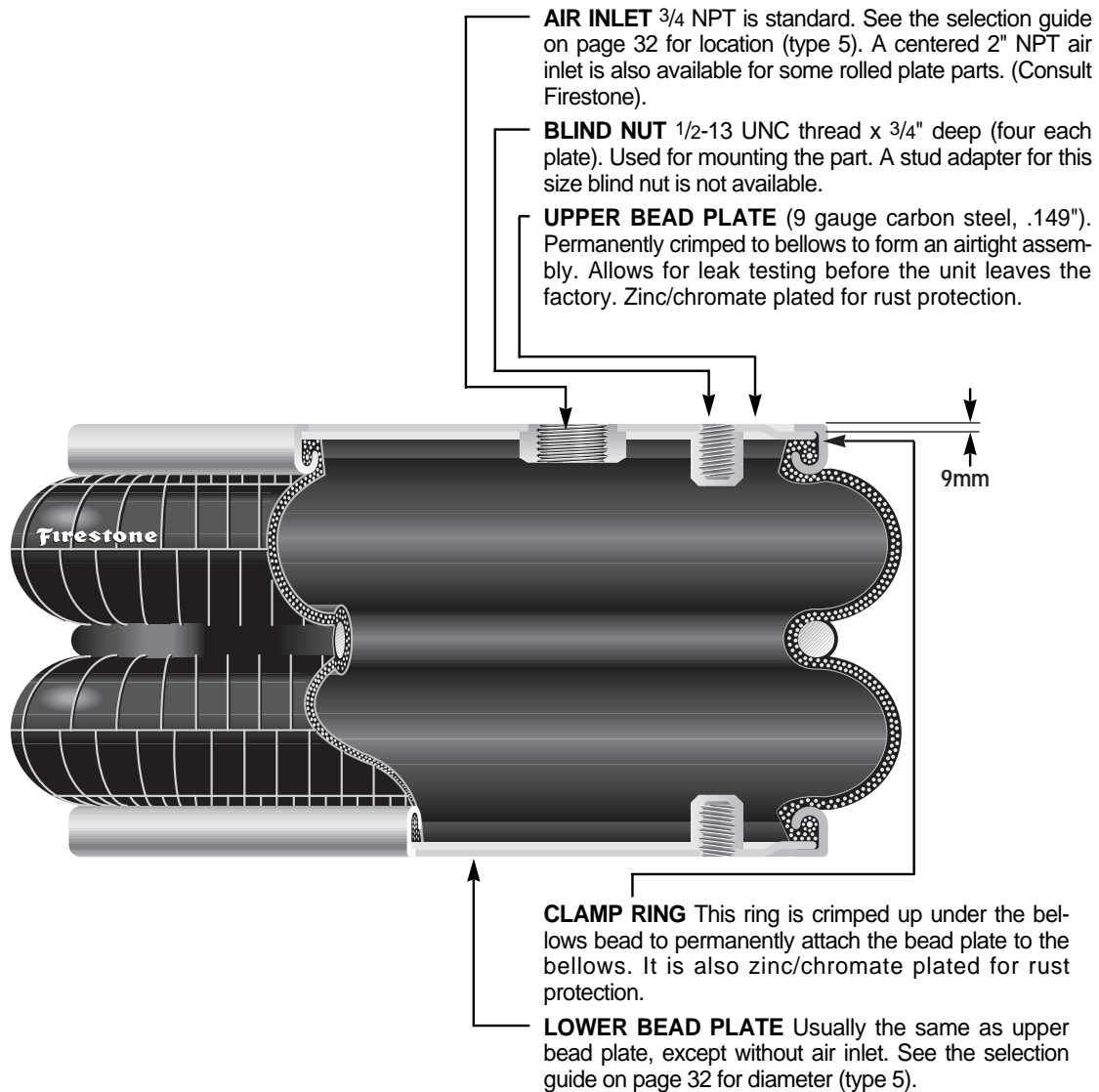

# HOW TO USE THE STATIC DATA CHART

We also refer to this chart as the load/deflection (L/D) curve for an air spring. The force [1] is given on the right hand axis vs. the air spring height [2] as shown along the bottom axis; thus, load vs. deflection. The internal volume [3] is also given along the left hand axis, again vs. height [2]. It is called static data because the air spring is in a static, or non-moving, constant pressure condition. In almost all cases the static curves were run using a two ply bellows; however, *where a four ply bellows is available, use the two ply chart for it also.*

## AIRSTROKE ACTUATION

The important considerations are minimum height [4] (3.0 inches) and maximum recommended height [5] (10.1 inches). Subtracting one from the other gives the stroke potential for this part (10.1 – 3.0 = 7.1 inches). As an actuator, the entire stroke may be used, or any portion thereof. *Ignore recommended airmount design height [6] and the corresponding darkened line [7].* This height is important in using the air spring as an isolator (AIRMOUNT). It has nothing to do with the concern here of actuation. To determine the force at any given height, simply move up the height line to where it intersects any of the static pressure curves. Then move to the right and read from the force scale [1].

EXAMPLE: At 80 psig, what is the force using a #22 from 4.0 to 9.0 inches, or 9.0 – 4.0 = 5.0 inch stroke? See [8] for force at 4.0 inches (7,180 #) and [9] for force at 9.0 inches (4,670 #). This example illustrates the primary difference between Firestone Airstrokes and conventional air cylinders. Air cylinders have a constant area for the pressure to work against, or constant effective area. *the effective area and force of an air spring changes as the height changes. (There is one exception: notice the plateau section of reversible sleeve 1T type curves.)*

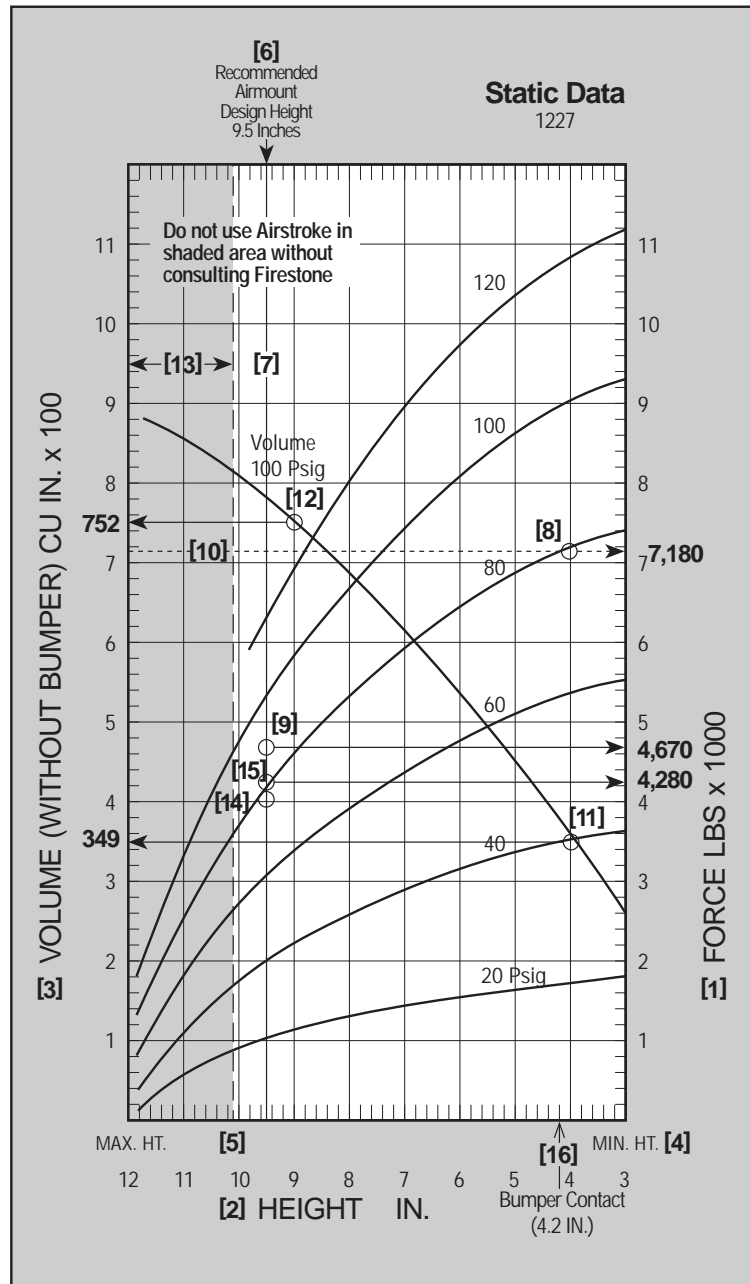

(There is one exception: notice the plateau section of reversible sleeve 1T type curves). In the example the effective area of a #22, at 4.0 inches using the 80 psi curve, is:

$$\frac{7,180 \text{ lbs.}}{80 \text{ lbs/in}^2} = 89.8 \text{ in}^2$$

at 9.0 inches in height it is:

$$\frac{4,670 \text{ lbs.}}{80 \text{ lbs/in}^2} = 58.4 \text{ in}^2$$

An air cylinder with 89.8 in<sup>2</sup> of area would have an 80 psi curve as shown by dotted line [10].

The volume curve [3] may also be of importance:

- a. If one needs to know the amount of free air (then compressed by the compressor) to perform a desired operation.
- b. If the actuation must be completed quickly and calculations of flow through the air inlet (orifice) are required.

In each case above, the change in internal volume is required. Read up from the two heights involved to the intersecting point with the volume curve. Then move to the left and read from the volume scale. In the example at 4.0 a #22 (notice most volume curves are at 100 psig) has an internal volume of 349 in<sup>3</sup> [11] and at 9.0 the volume is 752 in<sup>3</sup> [12]. The change in volume is then 752 in<sup>3</sup> – 349 in<sup>3</sup>, or 403 in<sup>3</sup>. The volume at minimum height (349 in<sup>3</sup>) would not be subtracted if exhausting the air spring to atmospheric pressure.

Notice the shaded area [13]. We do not recommend that an air spring be used at heights extending into this section. The "beginning of the shaded area" for a #22 is at 101 inches [5].

SEE PAGE 15 FOR A MORE DETAILED DISCUSSION OF ACTUATION.

## AIRMOUNT ISOLATION

Because of lateral stability considerations (see page 23 for more details) we recommend that each air spring be used at a *specific height* when used as an *isolator*. This specific height is called the "Airmount design height" [6]. The vertical line running through this height [7] is darkened so that it is easy to see where it intersects the static curves for load readings.

EXAMPLE: Support a 4,100 pound load with an air spring. Would a #22 be appropriate, and if so, at what height? The height isn't much of a problem, as this part **SHOULD BE USED AT 9.5 INCHES**. Simply move up the darkened line to where it intersects 4,100 lbs [14]. That point falls between the 80 and 60 psig curves. Exactly what pressure would be required? Use the formula:

$$\text{Effective Area} = \frac{\text{Load (lbs.)}}{\text{Pressure (lbs/in}^2\text{)}}$$

Determine the effective area at 9.5 inches (using the 80 psig curve, since 80 psig would be closer to our exact pressure than 60 psig), or:

$$\text{Effective Area} = \frac{4,280 \text{ lbs. [15]}}{80 \text{ lbs/in}^2} = 53.5 \text{ in}^2$$

Then divide the actual load by the effective area:

$$\frac{4,100 \text{ lbs.}}{53.5 \text{ in}^2} = 76.6 \text{ in}^2$$

The pressure required to support 4,100 lbs. with a #22 at a design height of 9.5 inches is therefore 76.6 PSIG.

Please note that the static data can be converted to dynamic data (the air spring is in motion) by applying the formulas that are presented in the Airmount isolation section on page 22.

SEE PAGE 21 FOR A MORE DETAILED DISCUSSION OF VIBRATION ISOLATION.

## INTERNAL RUBBER BUMPERS

Some parts are available with internal rubber bumpers. Where a bumper is available, it is shown as a dotted line in the cross sectional view of the air spring. Additionally, please note that:

1. the minimum height is increased to the "bumper contact" point [16] (this reduces the total available stroke somewhat, by 4.2 – 3.0 = 1.2 inches in our #22 example), and
2. the order block contains the proper ordering numbers for parts with bumpers.

# BASIC PARAMETERS APPLICABLE TO BOTH AIRSTROKE® ACTUATORS AND AIRMOUNT® ISOLATORS

## MEDIA

Air springs are designed for use with compressed air. Nitrogen is also acceptable. Air springs may be filled with water or water-glycol (automotive antifreeze) solutions. If water is to be used, rust inhibitors should be added to protect the end closures. Two reasons for liquid filling an air spring are:

1. To reduce the internal volume of air (and therefore, *increase* the natural frequency of the air spring) and,
2. To use a media which is incompressible. Accurate positioning would be one reason to do this.

Petroleum base fluids (most hydraulic oils fall into this category) are **NOT RECOMMENDED**. Moderately lubricated air will not harm the bellows.

## PRESSURE

Our "rule of thumb" is:

1. 100 psig maximum for 2 ply.
2. 175 psig maximum for high strength.

We recommend that there be a minimum three times safety factor between maximum internal air pressure and burst pressure. So, as an example, if 100 psig is required, the burst should be at 300 psig or greater. For convoluted air springs, the burst pressure decreases as height increases. Therefore, the determining factors are twofold: What is the maximum height into extension and what is the internal pressure at that point? Please see the Airstroke Inflation Pressure Chart (for single, double, and triple convoluted air springs) on page 17 for specific pressure vs. height information.

For AIRMOUNT applications (where the part is used at a height very close to the shaded area), it is best to stay within 100 psig maximum for a two ply, and 150 psig maximum for a four ply or high strength cord air spring.

## TEMPERATURE

**1. STANDARD BELLOWS.** Our standard industrial air springs should be limited to use in the range:

– 35° F to + 135° F.

**2. ALL NATURAL RUBBER (LOW TEMPERATURE COMPOUND).** A few of our industrial air springs are available in all natural rubber construction. This increases the acceptable cold or low end of the scale to – 65° F. The range then becomes – 65° F to +135° F.

**3. EPICHLOROHYDRIN (HIGH TEMPERATURE COMPOUND).** Most convoluted parts are available in this material. The operating temperature range for it is: 0° F to 225° F. Additionally, Epichlorohydrin has very good oil resistance. **ALL EPICHLOROHYDRIN APPLICATIONS MUST BE APPROVED BY FIRESTONE.** For more information on Epichlorohydrin (also known as Herclor), ask for Technigram number 111.

## CONTAMINATES

Shielding should be used to protect the bellows from exposure to hot metal, sand, petroleum base fluids, acids, etc. Please consult Firestone if you wish to know how the bellows will withstand a specific contaminant (For liquids such as acids, it is important to know both concentration and temperature).

## STORAGE

The best storage environment is a dark, dry area at normal room temperature.

## WARNING

DO NOT INFLATE ASSEMBLY WHEN IT IS UNRESTRICTED. ASSEMBLY MUST BE RESTRICTED BY SUSPENSION OR OTHER ADEQUATE STRUCTURE. DO NOT INFLATE BEYOND PRESSURES RECOMMENDED IN DESIGN LITERATURE (CONTACT FIRESTONE FOR INFORMATION). IMPROPER USE OR OVERINFLATION MAY CAUSE ASSEMBLY TO BURST CAUSING PROPERTY DAMAGE OR SEVERE PERSONAL INJURY.

# AIRSTROKE ACTUATION

## SELECTION

1. Refer to the selection guide on page 32 for Airstroke force and stroke capabilities. After your list of possibilities has been reduced to one or two air springs, then turn to the individual data page for more detailed information on those parts.
2. **STROKE:** The maximum STROKE CAPABILITY is the difference between the height corresponding to the “start of the shaded area” minus the minimum height. This entire stroke, *or any portion thereof*, may be used. If an internal rubber bumper is required, please note that the minimum height is increased, and therefore, the total stroke is decreased.
3. **FORCE:** Read the forces directly from the static data chart, or, use the force table located under the chart. Notice that the force generally decreases as height increases. This feature is discussed in detail on page 12 in the section entitled “How to Use the Static Data Chart.”
4. **SELECT THE END CLOSURES AND AIR INLET SIZE:** Most Airstroke actuators are available with permanently attached plates or bead ring attachments. If an alternate end closure option is available, it is so stated under the cross sectional view of the part. Please refer to page 6 for a detailed discussion of end closure options.

## DOWN AND UP STOPS

Positive stops in both directions (compression and extension) should always be used with Airstroke actuators .

1. In COMPRESSION, the minimum height shown for each air spring is at, or slightly above the PINCH POINT of the bellows. Here is a #22 shown in the collapsed or “pinch point” condition:

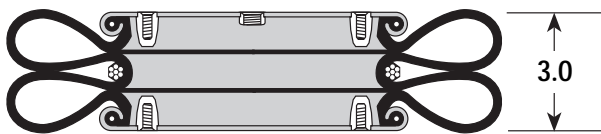

The bellows can be damaged if allowed to constantly bottom out as shown above; therefore, a downstop is required to prevent this. An external downstop can be something as simple as a steel block and should be sized at or slightly greater than the minimum height of the Airstroke. In our #22 example, the block would need to be at least 3.0 inches high. If an external downstop cannot be used, many parts are available with internal rubber bumpers (shown as a dotted line in the cross-sectional view of the air spring where available).

2. In EXTENSION, an upstop is required to prevent the air spring from overextending at heights into the shaded area of the graph. The reasons for this are twofold: **a)** the life of the bellows may be reduced and **b)** the crimp may open up, allowing the bellows bead to blow out of the metal end closure. There are many ways to design-in an upstop, including
  - a. a chain,
  - b. a cable,
  - c. contacting a metal stop, etc.

## RETURN

An Airstroke actuator is a *single acting* device. To return the Airstroke to its minimum height (for another cycle or stroke), some return force must be used. Gravity acting on the load may be all that's required. The force to collapse the convoluted type Airstrokes to minimum height is given in the order block section for each part. If the load is not sufficient, then a second Airstroke or coil spring may be required.

## GUIDING

*An Airstroke follows the path of least resistance;* therefore, the actuator should be guided in most instances. This is often easily accomplished in the mounting geometry.

## ANGULAR CAPABILITY

An Airstroke actuator can stroke through an arc (without a clevis). Angular motion of up to 30 degrees is possible. When using an actuator with the mounting plates at an angle to each other, observe the following:

- a. Measure force at the height between the plate centers.
- b. Measure maximum height at the side separated the furthest.
- c. Measure minimum height at the side collapsed the most.

**Angular Capability continued**

These measurements must fall within the guide lines for that particular part. Consider style #22 in the following scissors arrangement:

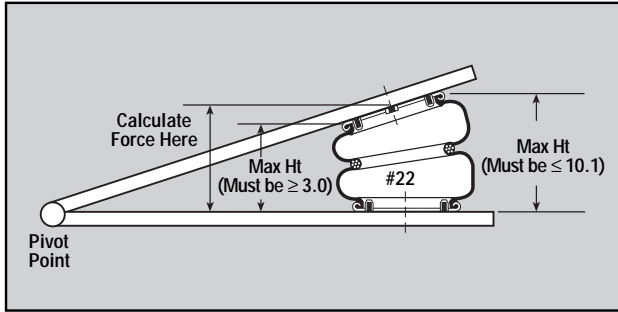

Reversible sleeve Type 1T parts may also stroke through an arc. In this case, care must be taken to prevent the bellows from rubbing (internally) against itself where it rolls over the piston:

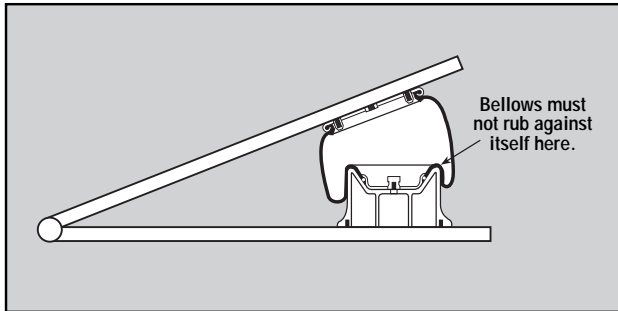

**HORIZONTAL MISALIGNMENT**

The upper and lower bead plate centers (or mounting plate centers in the case of a bead ring type attachment) may be out of line somewhat without injury to the bellows. Our “rule of thumb” for convoluted type Airstrokes is one inch misalignment allowed per convolution. So, a single convoluted air spring may be out of line by as much as 1 inch, a double by 2 inches, and a triple convoluted air spring by 3 inches.

**DESIGN ENVELOPE**

Adequate clearance should be provided around the Airstroke to prevent puncturing or rubbing of the bellows. The maximum diameter @ 100 psig for each Airstroke (bellows) is located just above the cross-sectional view of the air spring.

**STACKING**

It is permissible to stack Airstrokes (one on top of another) to increase stroke; however, the center plate (or plates) connecting the two or more Airstrokes **MUST BE GUIDED**.

Please note that the air spring forces are *not* additive in this configuration. A method for guiding, which also illustrates one center ring concept for mounting the two parts together at the middle, is illustrated below:

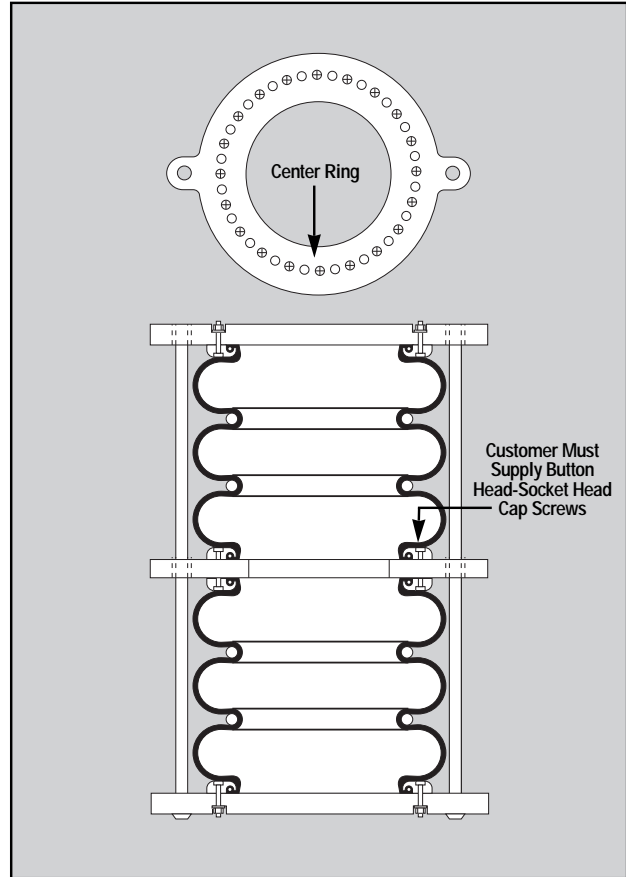

**FAIL SAFE DEVICES**

Some applications require the use of fail safe mechanisms (such as a mechanical lock-out on a scissors lift) to prevent damage or injury in the event of an air system failure.

**VACUUM**

An Airstroke can withstand a small amount of vacuum without injury to the bellows. The maximum amount of acceptable vacuum is dependent upon the bellows’ size, the height in use, and whether it is a two ply or high strength (fabric) air spring. (A high strength Airstroke bellows has a “stiffer” wall than a two ply; therefore, it is less susceptible to dimpling and deformation inward). It is generally best to use only single convoluted air springs under vacuum.

**An Airstroke Design Parameter Worksheet can be found on page 103.**



# AIRSTROKE

## INFLATION PRESSURE CHART

MAXIMUM RECOMMENDED INTERNAL PRESSURES FOR CONVOLUTED TYPE AIRSTROKE® ACTUATOR APPLICATIONS

BASED ON APPROXIMATELY 1/3 NORMAL BURST VALUES  
APPLICATIONS WHICH EXCEED THESE LIMITS SHOULD BE REVIEWED WITH FIRESTONE.

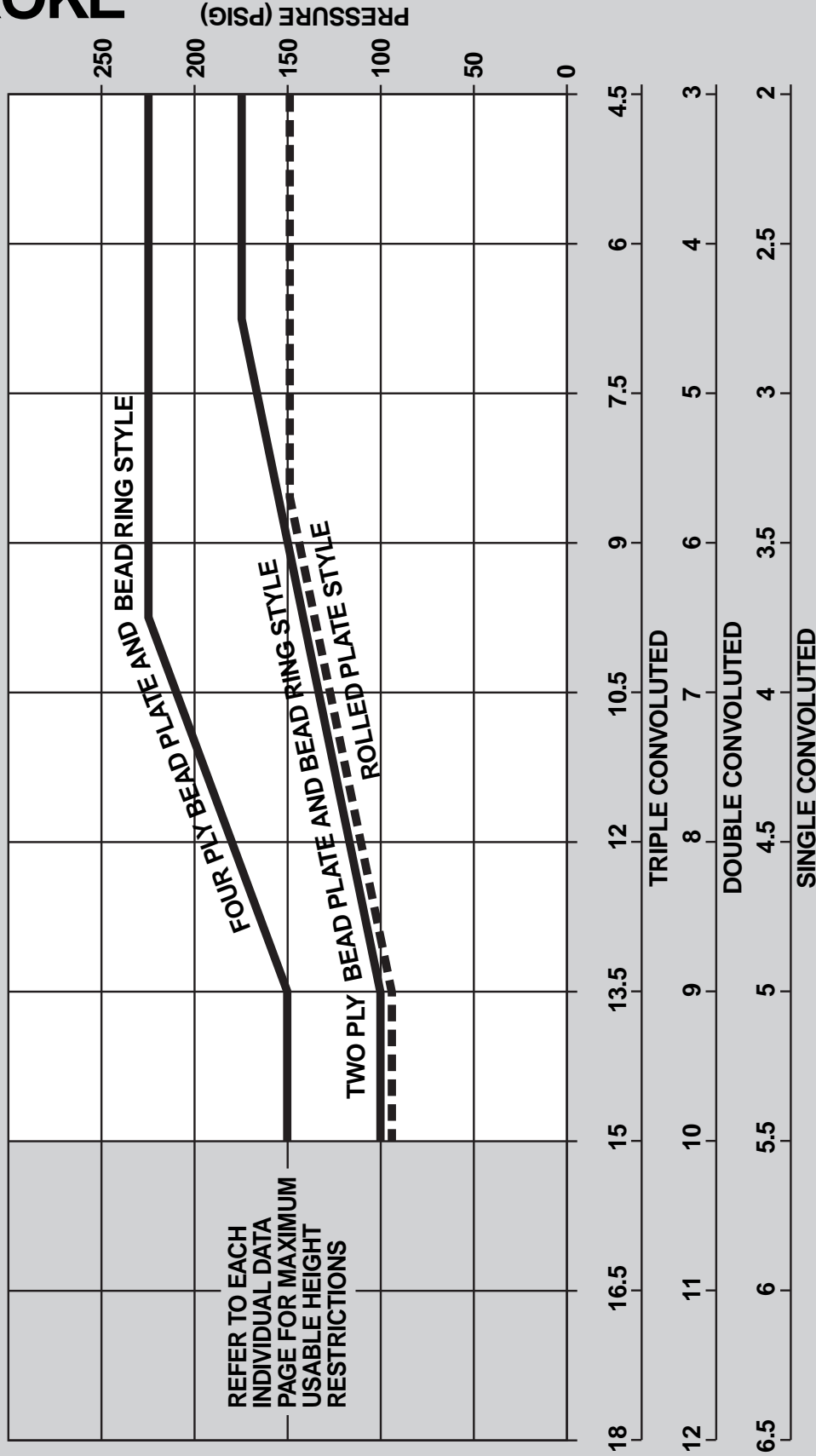

# AIRSTROKE® ACTUATOR PROBLEM SOLVERS

**GATE VALVE OPERATOR**

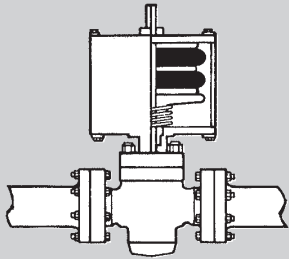

**GLUING PRESS**

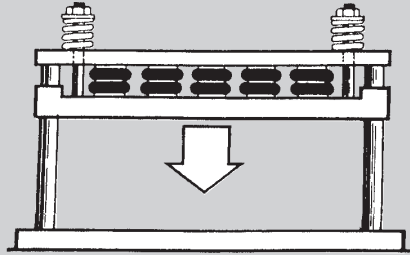

**WEB TENSIONING DEVICE**

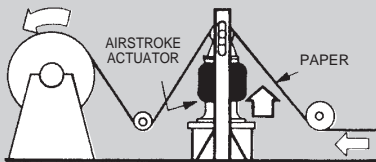

**DIE STRIPPER**

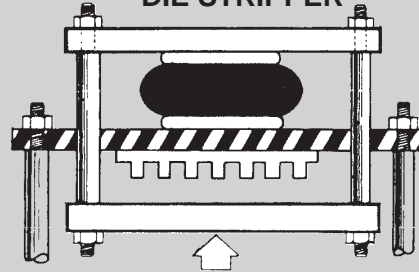

**KNIFE SPRING ACTUATOR**

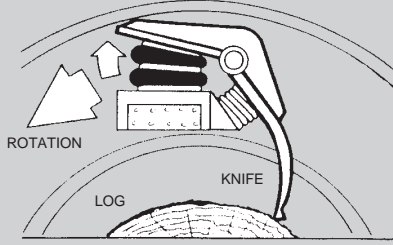

**QUENCH TANK ACTUATOR**

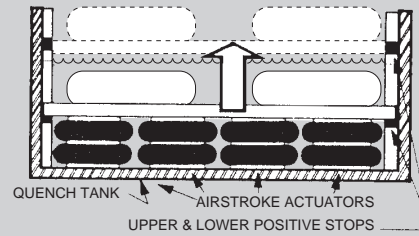

**PAPER SIZING PRESS**

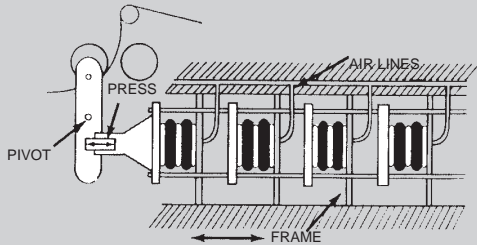

**PICKLING TANK ACTUATOR**

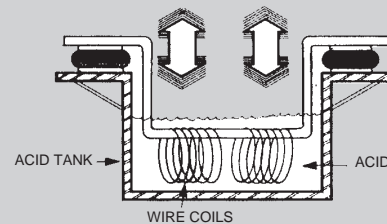

**QUICK LOCK DEVICE**

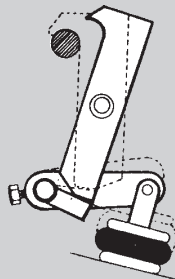

**PRESSURE ROLL FOR CALENDER**

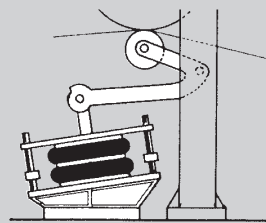

# AIRSTROKE® ACTUATOR PROBLEM SOLVERS

**MISSILE ASSEMBLY FIXTURE**

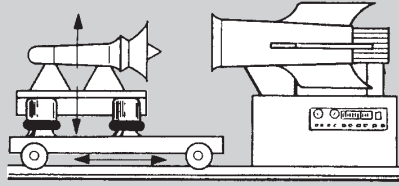

**CORE STRAIGHTENER**

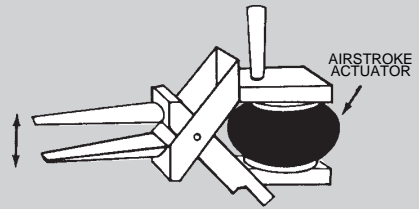

**BELT TAKE UP**

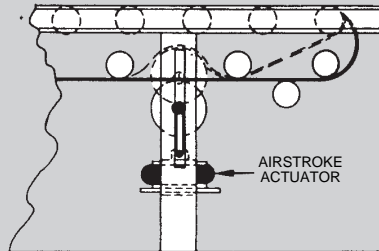

**ROLLER FRICTION BRAKE**

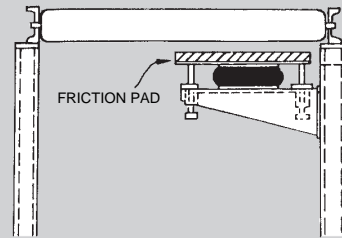

**PIPE INDEXING THREADING**

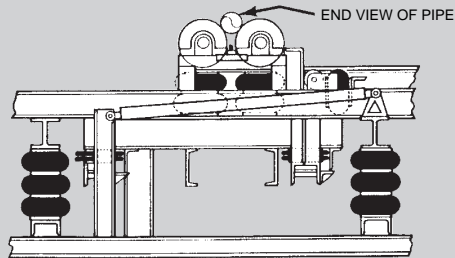

**OSCILLATING DOCTOR FOR PAPER CALENDER ROLL**

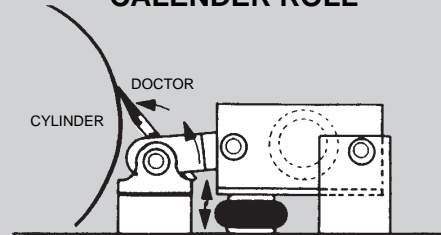

**FORMING PRESS**

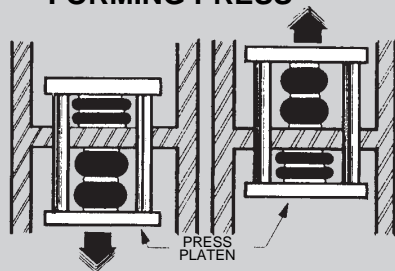

**CABLE TENSIONING DEVICE**

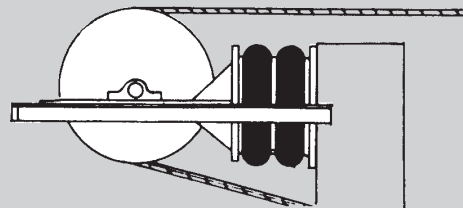

**BAG FLATTENER**

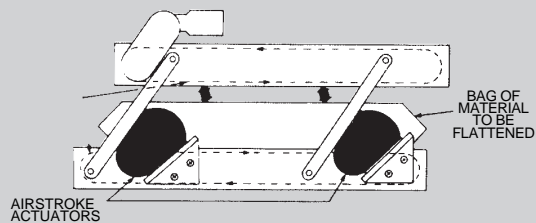

**TORSIONAL FRICTION BRAKE**

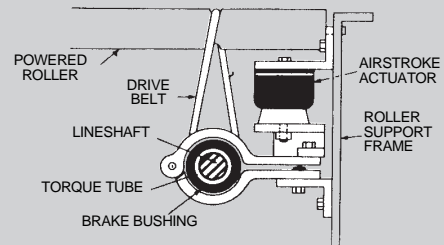

# AIRSTROKE® ACTUATOR PROBLEM SOLVERS

## HINGED GATE

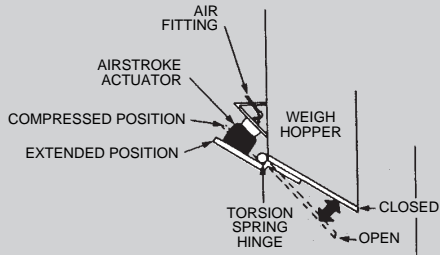

## HOT FOIL STAMPING PRESS

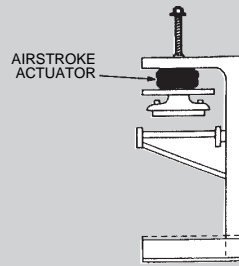

## ACTUATED HEAVY DUTY SEALER

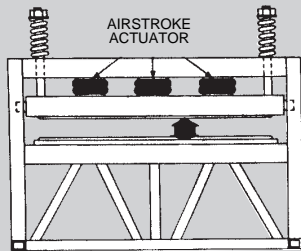

## PIVOTED CLAMPING DEVICE

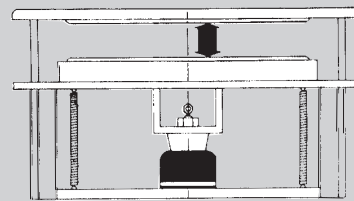

## AIRSTROKE ACTUATED ROLLER STOP

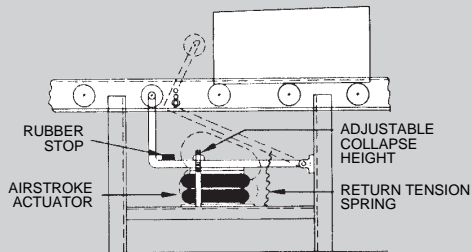

## HINGED ACTUATED GRAVITY GATE

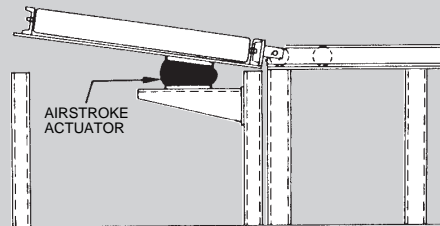

## VERTICAL ACTUATED DRIVE TABLE

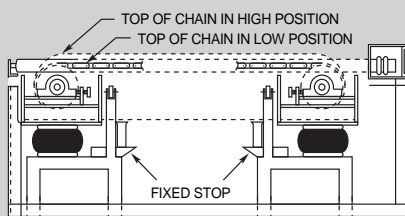

## SCISSOR LIFT

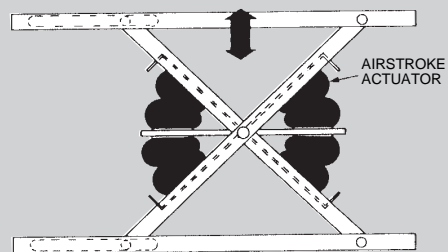

## CASE PACKER

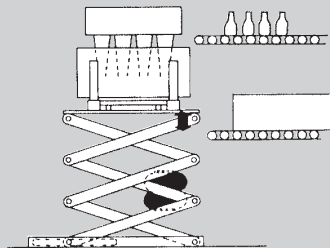

## CONVEYOR TRANSFER ACTUATOR

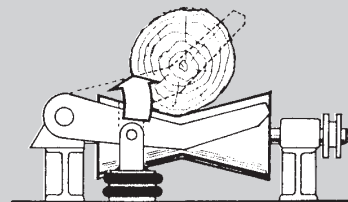

# AIRMOUNT® VIBRATION ISOLATION

## SELECTION AND ISOLATION FORMULA

Refer to the selection guide on page 33 for Airmount load and isolation capabilities. Follow this procedure:

### 1. LOAD CAPACITY

Select one or two Airmounts that can support the load at each mounting point. It is normally best to design for pressures in the 60 to 80 psig range. Consider only the 1M1A-0 and the single and double convoluted types at first. Please notice that in the range of 210 to 63,890 pounds you will, in most cases, find both a single and double convoluted style part which will support the load.

### 2. DETERMINE ISOLATION EFFECTIVENESS

Select the disturbing frequency that is closest to the actual forced frequency (400, 800, or 1500 cpm). Then check the percentage of isolation for the parts that were selected in 1 above.

### 3. DETERMINE DESIGN HEIGHT

THE AIR SPRING SHOULD BE USED AT THE DESIGN HEIGHT GIVEN. The double convoluted part is used at a design height somewhat higher than its single convolution equivalent. Make sure that the design height falls within the height restrictions. Also, the double convoluted part will show a higher percentage of isolation (less transmitted vibration) than the single convoluted air spring. The reason for this is that the double convoluted part has a greater internal volume of air than the single convoluted version of the same size. At disturbing frequencies in the 400 to 800 cpm range, the double convoluted part is a significantly better vibration isolator than the single convoluted part. At disturbing frequencies of 800 to 1500 cpm, the gap closes considerably. At frequencies of 1500 cpm and above, the difference is negligible.

### 4. DETERMINE EXACT INTERNAL PRESSURE AND ISOLATION EFFECTIVENESS

The chances are that your specific vibration problem does not fall neatly into the load and disturbing frequency criteria as presented in the selection guide.

Therefore, once a preliminary part selection has been made, turn to the individual data page for that part in order to determine the specific internal pressure required and the percentage of isolation attainable.

## CONSIDER THIS EXAMPLE:

Isolate a vibrating screen which weighs a total of 16,400 pounds, preferably with *one* isolator at each corner. The vibrating mechanism is rotating at a speed of 850 rpm (cpm) with a total stroke of  $\frac{5}{16}$  inch.

- a. Determine the load at each mounting point:

$$\frac{16,400}{4} = 4,100 \text{ lbs.}$$

Scan down the 80 psig load column in the selection guide. It appears that either a #19 or a #22 will support the load at a pressure between 60 and 80 psig.

- b. Determine Isolation Effectiveness.

Read the % of Isolation at 800 cpm for the #19 and #22 (since 800 is closest to our machine speed of 850 cpm). A #19 is at 96.0% and a #22 is at 98.2%. Looking at isolation effectiveness in terms of % TRANSMISSION, the #19 will transmit  $100 - 96.0$ , or 4.0% of the vibrations. A #22 will transmit  $100 - 98.2$ , or 1.8% of the vibrations. So, even though there does not seem to be much difference between 96.0% and 98.2% isolation, the #22 is in fact a better isolator by approximately a factor of two when comparing transmitted vibration.

- c. Determine Design Height.

Let's say we have chosen the #22 because 96.0% isolation for a #19 is considered to be too low. A #22 should be used at 9.5 inches as shown in the second column on page 33.

- d. Determine Exact Internal Pressure and Isolation Percentage.

Turn to page 61 for detailed information on the #22.

- a) What exact pressure will be required to support the load of 4,100 lbs? Refer to the information in the block entitled "Dynamic Characteristics at 9.5 in Design Height."

$$\frac{4,280 \text{ lbs.}}{80 \text{ lbs/in}^2} = 53.5 \text{ in}^2 = \text{effective area @ 9.5 inches @ 80 psig}$$

Divide the actual load by the effective area:

$$\frac{4,100 \text{ lbs.}}{53.5 \text{ in}^2} = 76.6 \text{ psig required to support 4,100 lbs. at 9.5 inches}$$

# AIRMOUNT® VIBRATION ISOLATION

b) What exact isolation will be attained?

Use the formula:

$$\% \text{ Transmission} = \frac{100}{\left(\frac{f_f}{f_n}\right)^2 - 1}$$

Where:  $f_f$  = Forced Frequency  
 $f_n$  = Natural Frequency

The forced frequency is 850 cpm. Read the natural frequency from the line at the load and pressure closest to the actual situation, or 106 CPM (@ 80 psig and 4,280 lbs.):

$$\% \text{ Transmission} = \frac{100}{\left(\frac{850}{106}\right)^2 - 1}$$

% Transmission = 1.6%  
 % Isolation = 100 - % Transmission  
 % Isolation = 100 - 1.6  
 % Isolation = 98.4%

Notice that the natural frequency of an Airmount changes only slightly with variations in pressure and load. Therefore, when working at pressures other than 40, 60, 80, or 100 psig, % isolation can be calculated quite accurately using the "closest" natural frequency and the formula above.

## DYNAMIC SPRING RATE FORMULA

Spring rate is a different matter. Unlike most conventional springs, the rate of an Airmount is not constant. It is a function of the change in effective area, volume, and pressure from design height. To determine the rate of an Airmount, use the following formula:

$$K = [P_g + 14.7] \left[ A_c \left( \frac{V_1}{V_c} \right)^{1.38} - A_e \left( \frac{V_1}{V_e} \right)^{1.38} \right] - 14.7(A_c - A_e)$$

WHERE:

$K$  = Vertical Spring Rate in lbs./inch  
 $P_g$  = Gauge Pressure at design height  $\left(\frac{\text{lbs}}{\text{in}^2}\right)$   
 $A_c$  = Effective Area at 1/2 inch below design height ( $\text{in}^2$ )  
 $A_e$  = Effective Area at 1/2 inch above design height ( $\text{in}^2$ )  
 $V_1$  = Internal Volume at design height ( $\text{in}^3$ )  
 $V_c$  = Internal Volume at 1/2 inch below design height ( $\text{in}^3$ )  
 $V_e$  = Internal Volume at 1/2 inch above design height ( $\text{in}^3$ )

Consider the same #22 example: What is the vertical spring rate with a load of 4,100 pounds at a design height of 9.5 inches? Refer to the static data chart on page 61. Again, our "closest" pressure is 80 psig, so we'll need to read the appropriate data from the 80 psig curve.

The 80 psig information at 1/2 inch above design height would fall at the 10.0 inch height line, and 1/2 inch below design height would fall at the 9.0 inch height line. (In this example, we can read loads from the force table). The information at design height is located in the "Dynamic Characteristics Block." So,

$K$  = Unknown

$P_g$  = 76.6 psig (see page 13)

$$A_c = 58.4 \text{ in}^2 \left( \frac{4,670 \text{ lbs.}}{80 \text{ lbs/in}^2} \right)$$

$$A_e = 47.6 \text{ in}^2 \left( \frac{3,810 \text{ lbs.}}{80 \text{ lbs/in}^2} \right)$$

$V_1$  = 782  $\text{in}^3$

$V_c$  = 752  $\text{in}^3$

$V_e$  = 809  $\text{in}^3$

$$K = [P_g + 14.7] \left[ A_c \left( \frac{V_1}{V_c} \right)^{1.38} - A_e \left( \frac{V_1}{V_e} \right)^{1.38} \right] - 14.7(A_c - A_e)$$

$$K = [76.6 + 14.7] \left[ 58.4 \left( \frac{782}{752} \right)^{1.38} - 47.6 \left( \frac{782}{809} \right)^{1.38} \right] - 14.7(58.4 - 47.6)$$

$K$  = 1,324 lbs/inch

## NATURAL FREQUENCY FORMULA

Once the spring rate is determined, calculate the Airmount natural frequency (for an *undamped* system) as follows:

$$f_n = 188 \sqrt{\frac{K}{L}}$$

Where:

$f_n$  = Natural Frequency in cycles per minute (cpm)

$K$  = Rate (lbs/inch)

$L$  = Load (pounds)

in our example:

$$f_n = 188 \sqrt{\frac{1,324}{4,100}}$$

$f_n$  = 106.8 cpm

# AIRMOUNT® VIBRATION ISOLATION

Up to this point, only the weight and disturbing frequency have been discussed. THERE ARE MANY OTHER IMPORTANT CONSIDERATIONS:

## CENTER OF GRAVITY

An Airmount isolation system is inherently soft (easily deflected); therefore, precautions must be taken to insure that the system is stable. First, consider the location of the center of gravity (c.g.). Ideally, the Airmounts should be located on the same plane (parallel to the ground) as the center of gravity. Where this is not possible, follow this guideline: The distance between the most narrow mounting points should be at least twice the height of the center of gravity.

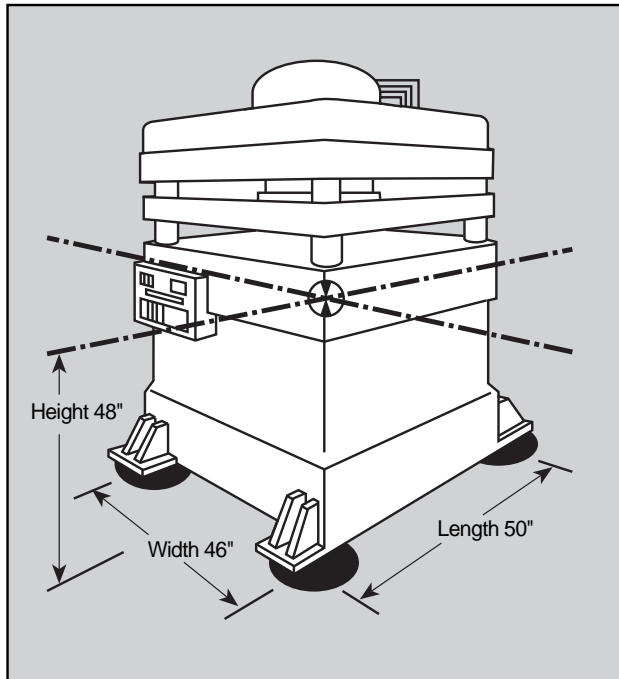

In the above example, the most narrow distance between two Airmounts is 46 inches. The height to the c.g. is 48 inches; therefore, this system does not meet our guideline. Two possible solutions would be:

1. Increase the base dimensions to meet our guideline by increasing both the width and length to at least 48 x 2 or 96 inches.
2. Locate the Airmounts at the c.g. as shown above (in the next column).

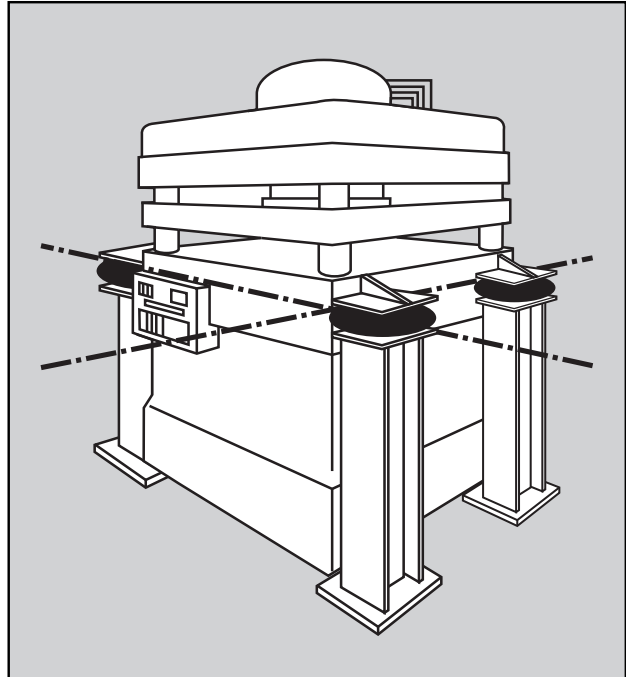

## LATERAL RATES AND STABILITY

Single and double convoluted air springs SHOULD BE USED AT THE DESIGN HEIGHTS GIVEN, because that is the point of maximum lateral rate or stability. The lateral rate *decreases* as the Airmount height *decreases*. Consider a #22 again at 80 psig:

Height	Lateral Rate	Vertical Rate
9.5 inch (design height)	325 lbs/in	1,373 lb/in
8.5 inch	212 lbs	—
7.5 inch	Unstable	—

Notice that the #22 becomes unstable in the horizontal or lateral direction when moving down only two inches from design height.

# AIRMOUNT® VIBRATION ISOLATION

At design height and without an auxiliary reservoir, the single and double convoluted parts follow this pattern; i.e., the lateral rate varies from  $1/5$  to  $1/2$  of the vertical rate (only the larger high strength parts get as high as  $1/2$ ). Notice the #22 is approximately  $1/4$  ( $\frac{325}{1,373}$ ). Going back to the original example of a vibrating screen which weighs 16,400 lbs. mounted on four #22's (@ 9.5 inches), a side load of 1,300 pounds ( $325 \times 4$ ) would deflect the entire suspended mass by one inch.

## TRIPLE CONVOLUTED AND REVERSIBLE SLEEVE TYPE PARTS

Both of these types are unstable laterally (except for the 1M1A). Due to low natural frequencies, both can be excellent isolators; however, do not use these two types as Airmount isolators without consulting Firestone (for special guidelines and precautions).

## DESIGN ENVELOPE

Adequate clearance should be provided around the Airmount to prevent puncturing or rubbing of the bellows. The maximum diameter @ 100 psig for each Airmount (bellows) is shown just above the cross sectional view of the air spring.

## SAFETY STOPS

It is normally recommended that positive stops be installed *in all directions*; i.e., into compression, extension, and laterally. Positioning of the vertical stops depends upon the amplitude of movement, both during normal operation and startup and shutdown. A good "rule of thumb" is  $\pm 1/2$  inch from design height for vertical stops and also  $\pm 1/2$  inch (horizontally) for lateral stops.

## INITIAL INSTALLATION

NEVER use Airmounts to lift equipment into place, due to the lateral instability at lower air spring heights as discussed previously. Equipment should be rested on stops set *slightly* below design height and raised into position for isolation.

## STARTUP AND SHUTDOWN/ RESONANCE AND AMPLIFICATION

Resonance is the condition where the forced frequency of the vibrating system is at the natural frequency of the suspension. When this happens, AMPLIFICATION of movement occurs. Going back to our vibrating screen example again, if the normal stroke is  $5/16$  of an inch, during startup and shutdown (as the machine goes through resonance), the amplitude of movement will be multiplied somewhat. So, while the machine is building up to speed and slowing down, the stroke may be amplified in the range of  $1/2$  to  $1 1/2$  inches. The longer the machine takes to go through resonance (to build up to, or slow down from full operating speed), the larger the amplitude of movement.

## ISOLATING AN UNBALANCED MASS

The primary concern in this case is the amplitude of movement. It is dependent on:

- 1) The ratio of the unbalanced moving mass to the total suspended mass, and
- 2) The ratio of the speed of the unbalanced moving mass (forced frequency) to the natural frequency of the Airmounts.

**The addition of damping to the isolation system (shock absorbers) will reduce the large amplitude of movement experienced during resonance.**

If the amplitude of movement is too great, one possible solution would be to add an inertia base in order to increase the ratio of the total suspended mass to the moving unbalanced mass. A good "rule of thumb" is 10:1, respectively.

## LOW PRESSURE OPERATION

The lateral rate of a single and double convoluted style Airmount *decreases* with decreasing internal air pressure (becomes unstable). Consult Firestone if you plan on operating an Airmount at less than 40 psig.

## EFFECT OF AN AUXILIARY RESERVOIR

There is a direct relationship between natural frequency and isolation effectiveness. Generally, the lower the natural frequency, the better the isolator (or higher percentage of isolation). As previously mentioned, a double convoluted Airmount has a lower natural frequency than a single convoluted type (of the same size) because it has more internal air volume. We can use this principle to lower the natural frequency of an air spring by adding an auxiliary reservoir (pressure vessel) externally to the Airmount. This effectively increases the air spring volume and reduces its natural frequency.

In order for the reservoir to work properly, there must be a free flow of air between the Airmount and reservoir. Therefore, it should be mounted as close as possible to the Airmount. Additionally, a bead ring attachment is the best end closure choice as the hole in the upper mounting plate can be sized as large as the inside diameter of the bellows (at the top). A  $3/4$ " NPT air inlet will restrict the flow of air somewhat, but can be used as long as it is understood that there is some throttling effect.

Going back to the #22 example, an auxiliary reservoir of three times the internal volume of the air spring at design height (approximately 10 gallons) will reduce the natural frequency from 106.8 cpm to 90.2 cpm. The spring rate also decreases, from 1,324 lbs./inch to 944 lbs./inch.



# AIRMOUNT® VIBRATION ISOLATION

## DAMPING

Damping is defined as the ratio:  $\frac{C}{C_c}$

WHERE: C = System Damping  
C<sub>c</sub> = Critical Damping

The damping ratio inherent in an Airmount is in the order of .03. This damping number is so small that the formulas presented in this section assume it to be zero.

## PLUMBING SYSTEMS

There are three basic ways of controlling an air suspended isolation system:

**1. With a TANK VALVE in each Airmount.** Each air spring is then inflated individually. The pressure in each must be checked periodically, because air will permeate through the bellows.

For an idea of the permeation rate, a #116 will lose approximately 30 psig over a period of one year (from 100 psig to 70 psig). Please see page 7 for a picture of a 1/4" NPT tank valve.

**2. Three Point Regulated System** The Airmounts can be connected directly to the factory compressed air system using pressure regulating valves. This eliminates the

need for periodic inspections. The air springs should always be connected in clusters so the mass is supported with only **THREE REGULATORS**. This is illustrated below (in the previous column) for both a four and eight Airmount system:

**3. Three Point Levelled System** Height control can be provided by adding height control valves to the system. Again, there should be only **THREE POINTS OF CONTROL**, or in this case, three leveling valves. Attempting to use more than three control points often results in the valves hunting or fighting one another. There are sensing systems available to control heights within ±.001 inch. Truck type leveling valves can provide accuracy to ±1/16 inch. A three point, eight air spring, leveled system is illustrated below:

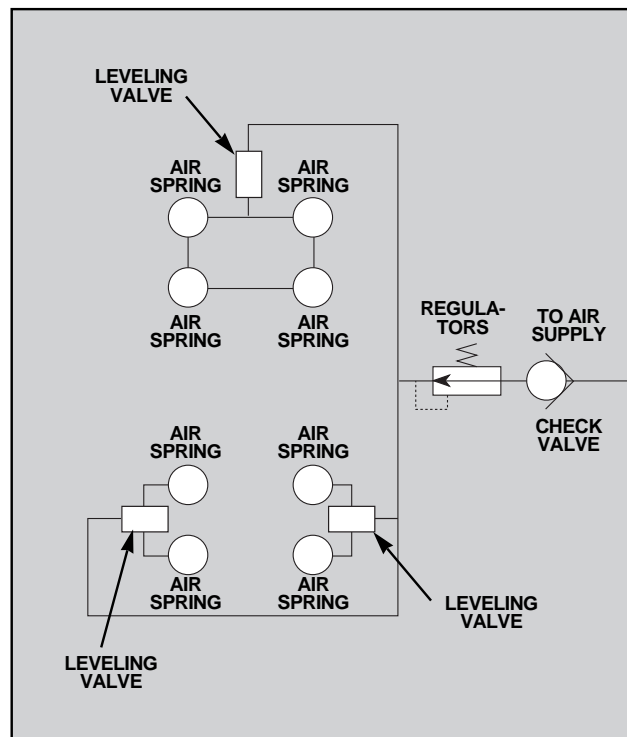
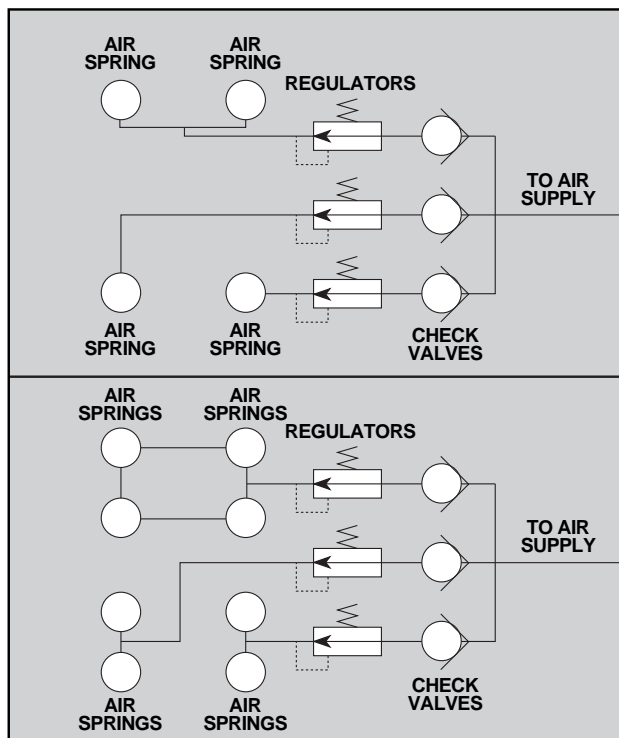

Firestone supplies height control valves and the accompanying linkages from the valve to the supported system.

Description	Order No.
Immediate Response Valve	WC1-358-3597
Immediate Response Valve Linkage	WC1-358-3594
Time Delay Valve	WC1-358-3599
Time Delay Valve Linkage	WC1-358-3598

An Airmount Design Parameter Worksheet can be found on page 105.

# AIRMOUNT® VIBRATION ISOLATION

## ISOLATION CHART

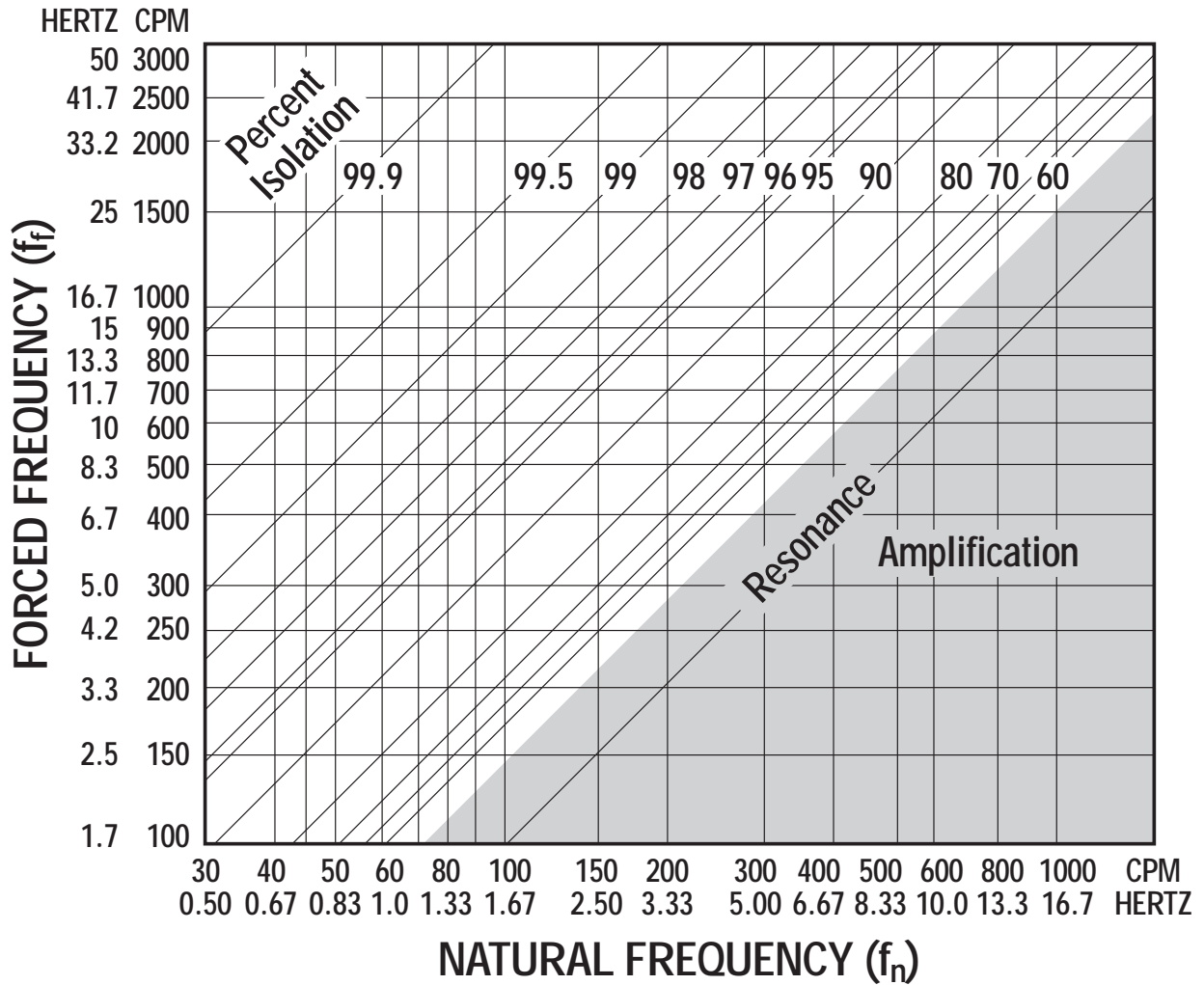

# AIRMOUNT® ISOLATION PROBLEM SOLVERS

VIBRATING PACKER

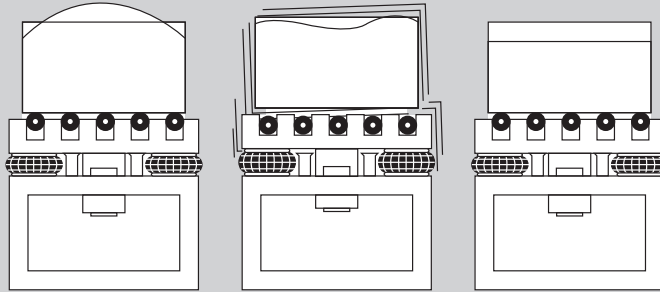

BIN HOPPER

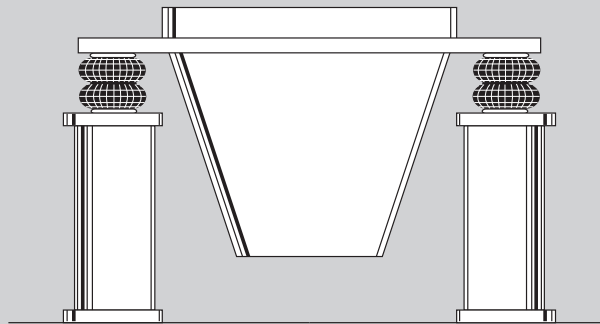

COMPRESSOR

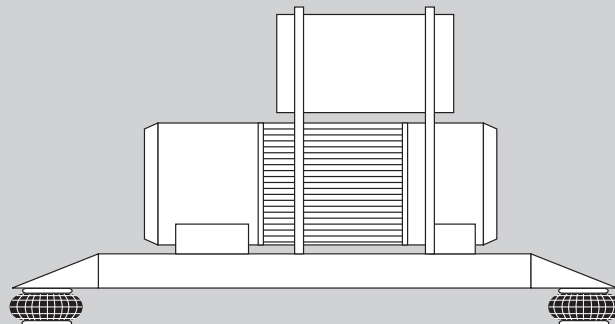

COMMERCIAL LAUNDRY MACHINE

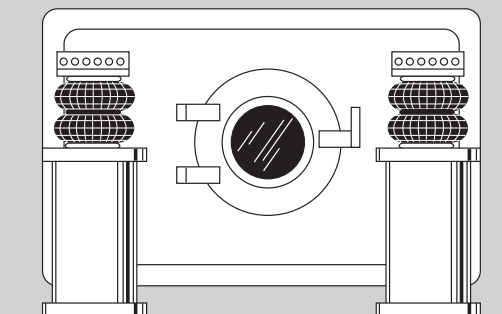

# AIRMOUNT® ISOLATION PROBLEM SOLVERS

**CONTROL BOOTH**

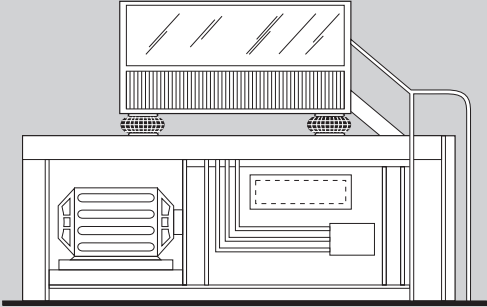

**VIBRATING SCREEN**

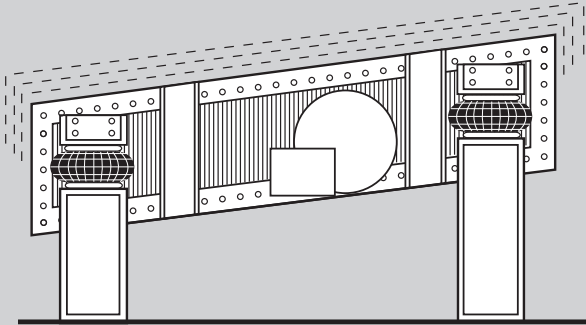

**BLOWER AND MOTOR**

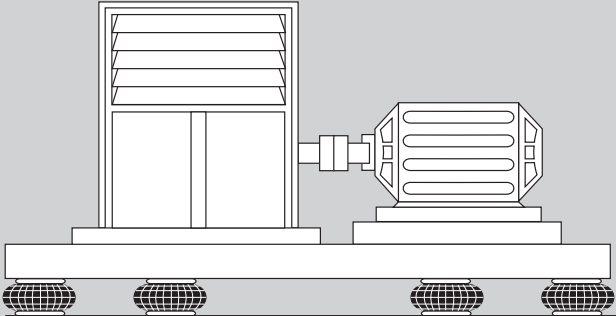

**CONTROL PANEL**

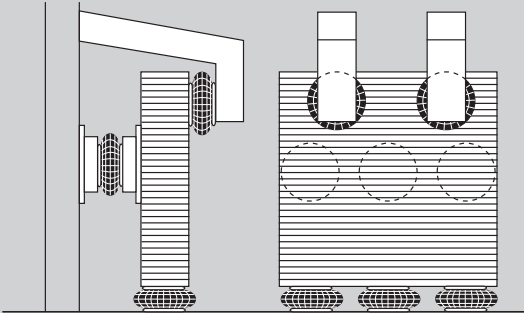

# MISCELLANEOUS APPLICATIONS

The air spring provides a unique solution for many actuation and isolation applications the world over. Besides the common applications, there are many that are not readily recognized because of the air spring's unique construction. Listed below are some miscellaneous applications.

## SHOCK IMPACT ISOLATION

The air spring is frequently used in shock impact isolation applications. This air spring application is commonly found in saw mills as the means to both absorb the shock of a falling log, and then by actuating the air spring, to lift and transfer a log onto a conveyor. Because of the properties of both air and rubber, the air spring is an ideal solution to this problem. Without it, the mechanism and surrounding structure would suffer fatigue and fail prematurely due to the intensity of the shock from the falling log. Refer to the problem solver section on the following pages for miscellaneous applications.

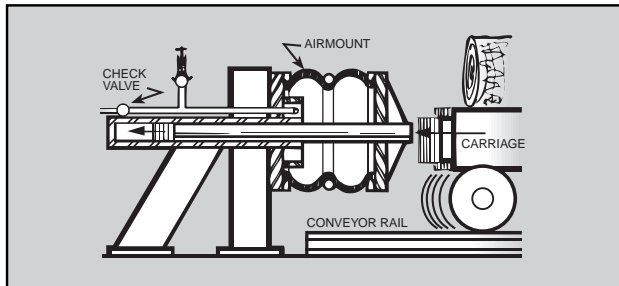

## PROTECTIVE BOOT AND FLEXIBLE CONNECTOR

An air spring bellows, with a bead ring type attachment, can be used as a protective boot or flexible connector. Due to the flexible construction of the air spring and the ability to handle both misalignment and angular movement, the air spring is a suitable solution to this problem. To protect the inner surface from the flow of material, an inner sleeve may be required. Refer to the problem solver section on the following pages for miscellaneous applications.

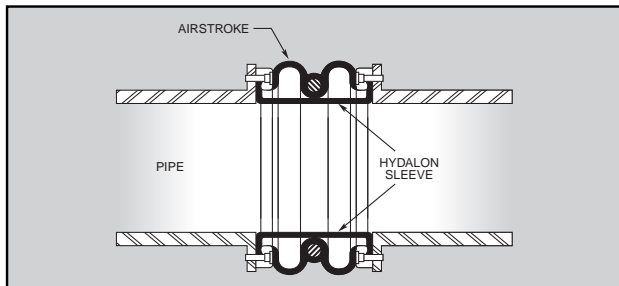

*For more information, call your local stocking distributor or the Firestone applications engineer at the phone number on the back cover of this design guide.*

## VACUUM PUMP

It is possible to drive an air spring mechanically in order to create a vacuum. The air spring can withstand a small amount of acceptable vacuum without injury to the bellows. The maximum amount of tolerable vacuum is dependent upon the bellows' size, height and whether it is a 2 ply or high strength air spring. It is generally best to use only the single convoluted air spring for this purpose. Refer to the problem solver section on the following pages for miscellaneous applications.

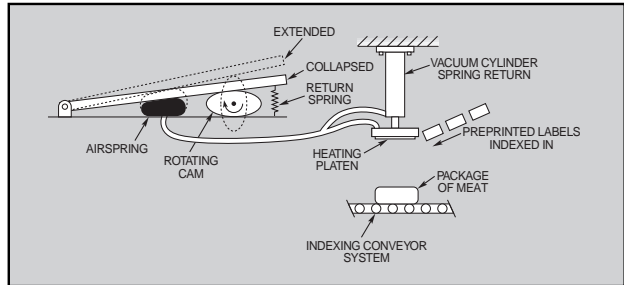

## INFLATABLE CHUCK

By restricting the height internally of a bead ring style air spring, the rubber walls will extend in an outward fashion. In this arrangement the air spring can be used as an inflatable chuck. The air will need to be introduced via the same mechanism that restrains the air spring's height. Refer to the problem solver section on the following pages for miscellaneous applications.

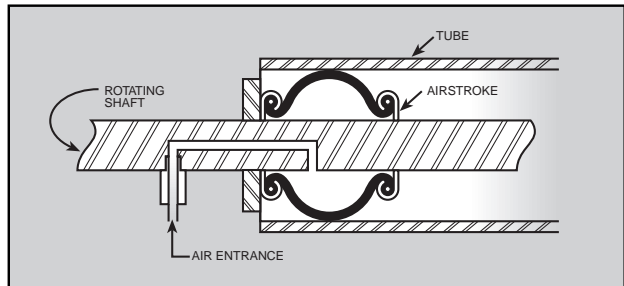

## CAM FOLLOWER

The introduction of an air spring as the cam follower can extend the life of the cam greatly. Surface wear is reduced by removing the rigidity and friction of typical cam followers. With this reduction of wear comes continually smooth operations and overall minimization of fatigue. Refer to the problem solver section on the following pages for miscellaneous applications.

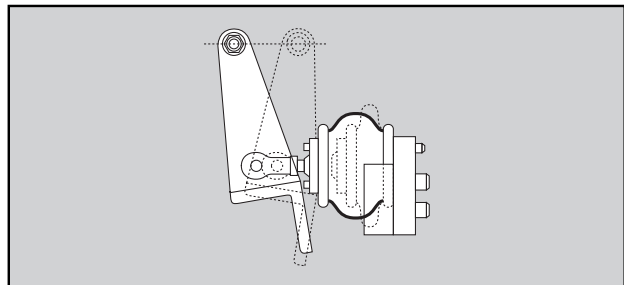

# MISCELLANEOUS PROBLEM SOLVERS

**ROBOTIC COUPLING**

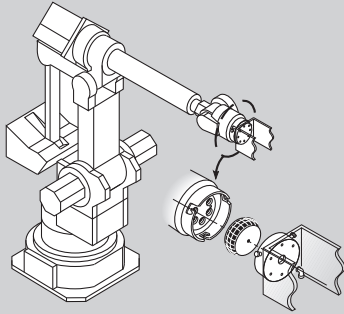

**CONVEYOR END STOP**

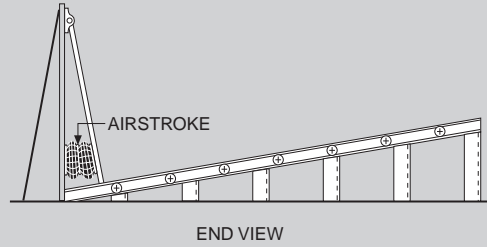

**MOUNTAIN/TRAIL BIKE**

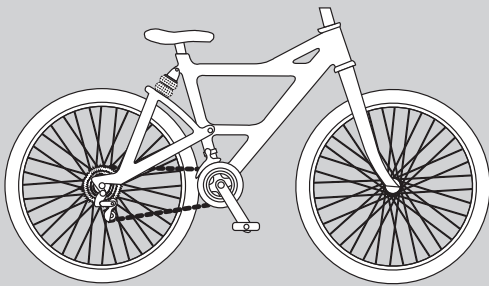

**SHOCK ABSORBER TEST SYSTEM**

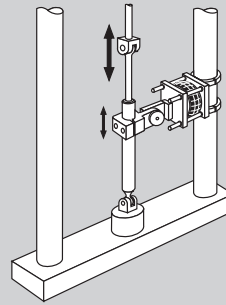

**SCREENING MACHINE COVER CLAMP**

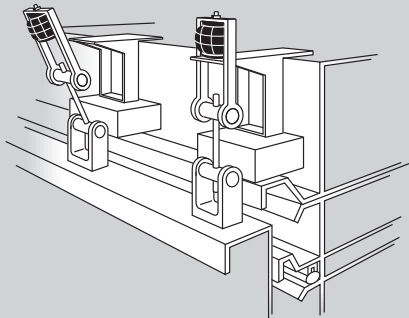

**PIPE CRAWLER**

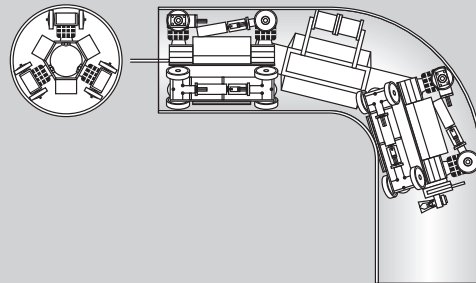

**DELICATE ELECTRONIC EQUIPMENT**

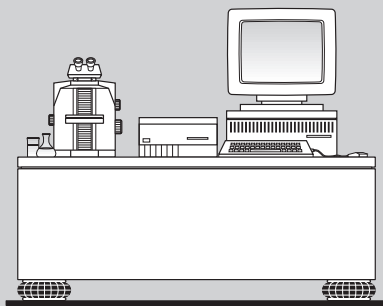

**VIBRATING SCREEN**

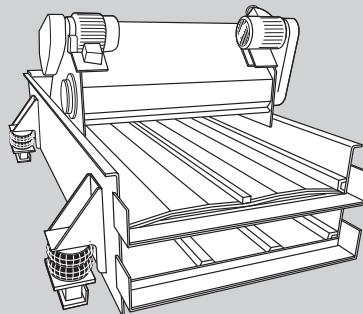

# MISCELLANEOUS PROBLEM SOLVERS

**SHEET WELDING CLAMP**

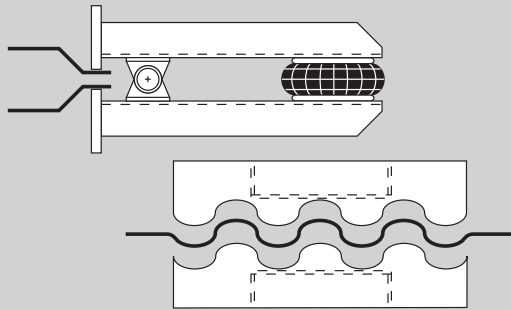

**SWASH PLATE MOTOR**

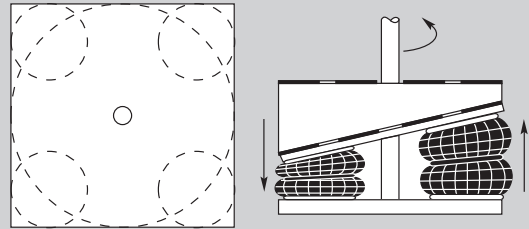

**PERFECT BOUND MAGAZINE CUTTER**

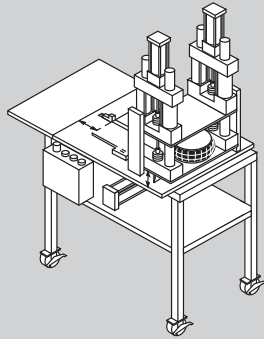

**WAVE POWER MODULE**

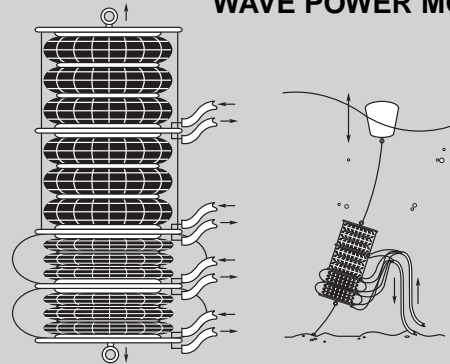

**CHECK VALVE LAPPING**

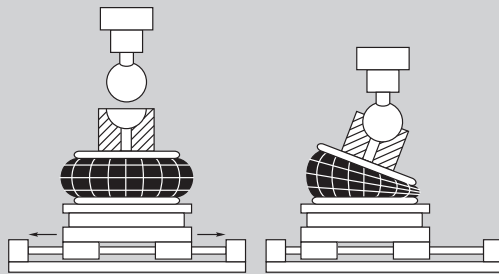

**SELF ALIGNING DEVICE**

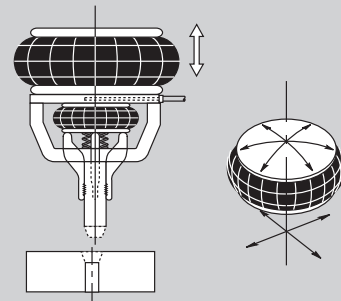

**AIR BLAST GENERATOR**

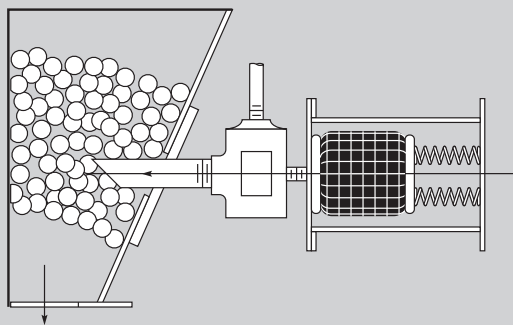

**SOLAR TRACKER**

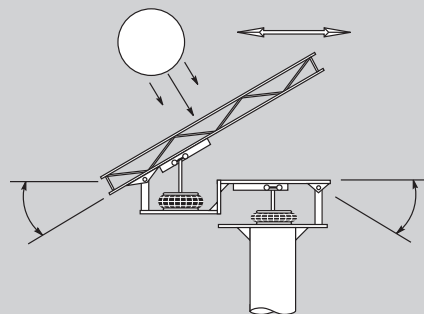

# Firestone SELECTION GUIDE

## AIRSTROKE® ACTUATORS

Style Number	Maximum Diameter at 100 PSIG (inches)	Minimum Height (inches)	Maximum Stroke (inches)	Maximum Usable Height (inches)	80 PSI Force* at Stroke of			High Strength Style Number
					1 Inch (pounds)	3 Inches (pounds)	Maximum Stroke (pounds)	

### SHAPED SLEEVE

1M1A-0	3.4	1.5	1.4	2.9	450		400	
1M1A-1	3.45	1.5	2.0	3.5	600		500	
2M1A	3.5	2.5	3.4	5.9	470	410	360	
2M2A	2.3	1.2	1.0	2.2	10.8		10.8	

### SINGLE CONVOLUTION

16	6.0	1.9	1.4	3.3	960		620	
16ST	5.4	1.5	1.8	3.3	1,330		780	
131	6.5	2.0	2.1	4.1	1,350		850	
110	8.3	2.0	3.1	5.1	2,090	1,030	940	
116	9.1	2.0	3.1	5.1	2,690	1,370	1,300	117
116-1	9.6	2.0	4.2	6.2	2,980	2,240	1,460	
115	10.1	2.0	3.1	5.1	3,550	1,730	1,620	124
19	12.9	2.0	3.5	5.5	6,720	4,500	3,400	
19-.75	13.5	2.0	3.9	5.9	7,040	5,000	3,250	
113	15.2	2.0	3.8	5.8	9,900	6,890	4,650	128
113-1	15.9	2.0	4.6	6.6	10,860	8,800	5,500	128-1
153-2	18.1	2.5	4.8	7.3	13,135	10,604	6,422	
119**	17.4	2.0	4.2	6.2	14,030	11,450	7,850	
121**	20.3	2.0	3.6	5.6	19,600	14,450	11,350	
126**	22.4	2.0	4.4	6.4	25,990	22,460	16,000	
138-1.5	27.9	2.0	5.3	7.3	43,430	38,230	22,700	
148-1	37.4	2.5	4.8	7.3	78,300	67,690	52,500	148-1 is 4Ply

### DOUBLE CONVOLUTION

25	6.4	2.8	3.3	6.1	1,380	780	660	
255-1.5	6.5	3.0	4.0	7.0	2,039	1,786	1,198	
224	8.0	2.8	4.9	7.7	2,350	1,760	1,030	
26	8.6	3.0	5.7	8.7	2,700	2,230	1,420	
20	9.9	3.0	6.1	9.1	3,790	3,180	1,770	202
20-2	10.4	3.0	8.0	11.0	4,125	3,753	2,122	
22	12.9	3.0	7.1	10.1	7,180	6,470	3,700	210
22-1.5	13.7	3.0	7.8	10.8	7,680	6,990	3,830	
21	15.1	3.0	7.1	10.1	10,300	9,310	5,670	205
21-2	16.0	3.0	8.7	11.7	11,330	10,670	5,850	
233-2	15.5	3.0	10.4	13.4	10,966	10,564	5,900	
28**	17.4	3.3	6.8	10.1	15,000	13,200	8,530	201
203**	20.0	3.3	7.2	10.5	21,400	19,200	12,910	218
29**	22.7	3.3	7.5	10.8	26,900	24,400	17,280	207
200	26.0	3.3	7.3	10.6	35,700	33,300	24,250	
215	27.9	3.3	8.8	12.1	42,500	40,000	28,160	
248-2	37.4	4.2	9.1	13.3	78,200	74,100	53,990	248-2 is 4 Ply

### TRIPLE CONVOLUTION

352	13.1	4.5	11.2	15.7	8,030	7,340	4,080	
313	15.1	4.5	10.5	15.0	10,650	9,700	5,460	39
333	15.2	4.5	12.0	16.5	10,921	10,033	5,800	
312**	18.2	4.5	10.4	14.9	15,700	14,200	8,740	314
323**	20.5	4.5	10.9	15.4	21,200	19,500	12,420	324
320**	22.4	4.5	11.8	16.3	28,700	26,700	17,390	328
321	27.9	4.5	14.2	18.7	43,300	41,200	26,420	
348-3	37.4	5.5	13.8	19.3	77,000	74,000	53,600	348-3 is 4Ply

### REVERSIBLE SLEEVE

1X84D-1	5.2	DO NOT USE 1X84D-1 AS AN AIRSTROKE ACTUATOR						
4001	3.1	3.6	7.2	280	310	310		
7002	4.2	3.5	2.5	6.0	710	660	660	
7010	4.0	5.75	4.25	10.0	570	600	640	
7012	5.0	5.0	4.5	9.5	690	750	760	
1T12E-3	5.0	6.0	7.6	13.6	750	600	540	
1T14C-1	9.1	5.0	7.7	12.7	2,790	2,570	1,720	
1T14C-3	9.0	5.8	8.2	14.0	2,930	2,550	1,780	
1T14C-7	9.0	8.0	9.4	17.4	3,040	2,610	1,630	1T28C-7
1T15T-1	11.2	4.0	6.7	10.7	5,010	4,370	2,910	
1T15S-6	11.1	6.0	10.0	16.0	5,070	4,420	2,830	
1T15L-4	11.7	6.0	9.9	15.9	5,690	5,500	3,680	
1T15M-0	12.8	4.3	7.0	11.3	5,700	5,550	3,840	
1T15M-2	12.6	5.0	8.3	13.3	6,080	5,930	4,060	
1T15M-4	12.6	6.0	10.5	16.5	6,270	5,730	4,020	
1T15M-6	12.6	7.0	12.2	19.2	6,280	5,730	3,950	
1T15M-9	12.7	8.5	15.1	23.6	6,450	5,850	4,210	
1T19L-7	14.2	6.0	12.8	18.8	8,800	7,300	4,700	
1T19L-11	14.2	8.0	15.4	23.4	8,600	7,300	5,100	

## END CLOSURE OPTIONS

Bead Plate Type	Dim. A (blind nut centers) (inches)	Dim. B (inches)	Bead Ring Type	Dim. C (bolt circle diameter) (inches)	Number of Bolts (each ring)
-----------------	-------------------------------------	-----------------	----------------	--	-----------------------------

SEE INDIVIDUAL DATA PAGE

1	1.75		4	4.50	6
1	1.75		N/A	N/A	N/A
1	1.75		4	4.50	6
1	1.75		4	4.50	6
1	2.75		4	5.31	6
1	2.75		4	5.31	6
3	3.50	1.75*	4	6.31	8
3	6.20	2.88	4	9.00	12
3	6.20	2.88	4	9.00	12
2	6.25		4	11.31	12
2	6.25		4	11.31	12
2	6.25		N/A	N/A	N/A
5	9.00	13.79	4	13.81	18
5	12.00	16.50	4	16.50	24
5	15.00	19.00	4	19.00	24
			4	23.50	32
			4	32.68	40

1	1.75		4	4.50	6
1	1.75		4	4.50	6
1	2.75		4	5.31	6
1	2.75		4	5.31	6
3	3.50	1.75*	4	6.31	8
3	3.50	1.75	4	6.31	8
3	6.20	2.88	4	9.00	12
3	6.20	2.88	4	9.00	12
2	6.25		4	11.31	12
2	6.25		4	11.31	12
2	6.25		4	11.31	12
5	9.00	13.79	4	13.81	18
5	12.00	16.50	4	16.50	24
5	15.00	19.00	4	19.00	24
			4	22.00	24
			4	23.50	32
			4	32.68	40

3	6.20	2.88	N/A	N/A	N/A
2	6.25		4	11.31	12
2	6.25		4	11.31	12
5	9.00	13.79	4	13.81	18
5	12.00	16.50	4	16.50	24
5	15.00	19.00	4	19.00	24
			4	23.50	32
			4	32.68	40

SEE INDIVIDUAL DATA PAGE

1	1.75		4	4.50	6
3	3.50	1.75*	4	6.31	8
3	3.50	1.75*	4	6.31	8
3	3.50	1.75*	4	6.31	8
3	6.20	2.88	4	9.00	12
3	6.20	2.88	4	9.00	12
3	6.20	2.88	4	9.00	12
3	6.20	2.88	4	9.00	12
3	6.20	2.88	4	9.00	12
3	6.20	2.88	4	9.00	12
3	6.20	2.88	4	9.00	12
2	6.25		4	11.31	12
2	6.25		4	11.31	12



# AIRMOUNT® ISOLATORS

Style Number	Design Height	Load (at Design Height) at:			Natural Frequency (@ 80 PSIG) f <sub>n</sub> (cpm)	% of Isolation at Forced Frequency		
		**40 PSIG (pounds)	60 PSIG (pounds)	80 PSIG (pounds)		400 CPM %	800 CPM %	1500 CPM %
<b>SHAPED SLEEVE</b>								
1M1A-0	2.5	210	330	450	220		91.8	97.8
1M1A-1	3.0	235	356	475	162	90.0	95.5	98.6
2M1A	DO NOT USE 2M1A AS AN AIRMOUNT ISOLATOR							
2M2A	2.0	73	105	137	232		90.8	97.5

## SINGLE CONVOLUTION

16	3.0	420	640	880	237		90.3	97.4
16ST	3.0	400	600	800	240	87.0	97.0	99.2
131	3.5	550	850	1,170	181	74.4	94.6	98.5
110	4.5	650	1,010	1,390	162	80.2	95.7	98.8
116	4.5	850	1,330	1,830	163	80.2	95.7	98.8
116-1	5.5	940	1,410	1,930	139	86.3	96.9	99.1
115	4.5	1,180	1,750	2,350	166	79.1	95.5	98.8
19	5.0	2,130	3,310	4,500	156	82.1	96.0	98.9
19-.75	5.5	1,890	2,950	4,080	156	82.0	96.0	98.9
113	5.0	3,220	5,030	6,890	150	83.6	96.4	99.0
113-1	5.5	3,820	5,900	7,990	133	87.7	97.2	99.2
153-2	6.0	4,564	7,048	9,682	121	89.9	97.7	99.3
119**	5.0	5,490	8,450	11,450	138	86.5	96.9	99.1
121**	5.0	6,450	10,300	14,450	142	85.5	96.7	99.1
126**	5.0	11,030	16,710	22,460	133	87.5	97.1	99.2
134-15/138-15	6.0	15,870	24,490	32,890	124	89.3	97.5	99.3
148-1	5.5	32,860	50,290	67,690	118	90.5	97.8	99.4

## DOUBLE CONVOLUTION

25	5.5	430	670	910	154	82.5	96.1	98.9
255-1.5	6.0	566	871	1,194	129	87.6	97.2	99.2
224	6.5	730	1,130	1,530	126	89.0	97.5	99.3
26	8.0	790	1,230	1,670	111	91.6	98.0	99.4
20	8.5	990	1,540	2,130	116	90.7	97.8	99.4
20-2	10.0	1,184	1,848	2,531	97	93.7	98.5	99.5
22	9.5	2,060	3,170	4,280	106	92.4	98.2	99.5
22-1.5	10.5	1,930	3,030	4,130	106	92.4	98.2	99.5
21	9.5	3,030	4,750	6,540	105	92.6	98.3	99.5
21-2	10.5	3,460	5,350	7,280	95	94.1	98.6	99.6
233-2	11.25	3,413	5,631	7,691	89	95.0	98.8	99.7
28**	9.5	4,590	7,010	9,590	101	93.2	98.4	99.5
203**	9.5	7,210	11,100	14,970	97	93.7	98.5	99.6
29**	9.5	9,780	14,860	20,060	92	94.4	98.7	99.6
200	9.5	13,290	20,390	27,330	93	94.2	98.6	99.6
211/215	10.5	15,840	24,140	32,550	86	95.1	98.8	99.7
248-2	11.0	30,830	47,720	63,890	83	95.5	98.9	99.7

## TRIPLE CONVOLUTION

352	13.5	2,319	3,631	5,017	77	95.9	99.0	99.7
313	13.0	3,310	5,120	7,020	82	95.6	98.9	99.7
333	14.7	3,282	5,167	7,000	77	96.1	99.1	99.7
312**	13.0	5,100	7,930	10,730	80	95.8	99.0	99.7
323**	13.0	7,380	11,520	15,550	77	96.1	99.1	99.7
320**	14.0	10,340	15,580	21,080	73	96.5	99.2	99.8
319/321	15.0	16,220	24,690	33,290	70	96.8	99.2	99.8
348-3	15.0	31,480	47,870	64,870	68	97.0	99.3	99.8

## REVERSIBLE SLEEVE

1X84D-1	8.0	310	500	680	71	96.8	99.2	99.8
4001	5.5	150	220	290	105	92.7	98.3	99.5
7002	4.5	310	480	650	114	91.2	97.9	99.4
7010	8.0	280	440	600	83	95.5	98.9	99.7
7012	8.5	360	590	790	75	96.3	99.1	99.7
1T12E-3	10.5	290	450	600	73	96.5	99.2	99.8
1T14C-1	10.0	1,210	1,880	2,540	86	95.1	98.8	99.7
1T14C-3	11.0	1,230	1,890	2,570	76	96.2	99.1	99.7
1T14C-7	13.5	1,250	1,910	2,600	64	97.4	99.4	99.8
1T15T-1	7.0	2,100	3,220	4,370	97	93.7	98.5	99.6
1T15S-6	12.0	2,040	3,140	4,220	74	96.5	99.1	99.8
1T15L-4	11.0	2,650	4,080	5,510	82	95.6	98.9	99.7
1T15M-0	7.5	2,670	4,120	5,540	94	94.1	98.6	99.6
1T15M-2	9.5	2,850	4,370	5,900	86	95.2	98.8	99.7
1T15M-4	12.5	2,760	4,200	5,670	71	96.8	99.2	99.8
1T15M-6	15.0	2,720	4,110	5,560	67	97.1	99.3	99.8
1T15M-9	18.5	2,780	4,250	5,680	58	97.8	99.5	99.8
1T19L-7	15.0	3,476	5,264	7,052	70	96.8	99.2	99.8
1T19L-11	18.0	3,411	5,151	6,911	63	97.5	99.4	99.8

# END CLOSURES

## TYPE 1 bead plate

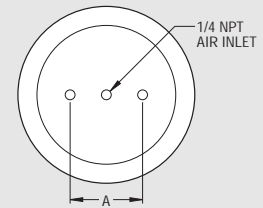

## TYPE 2 bead plate

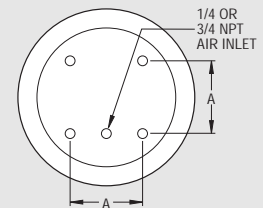

## TYPE 3 bead plate

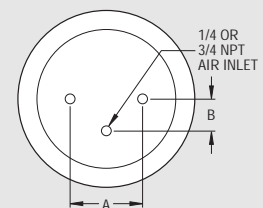

## TYPE 4 bead ring

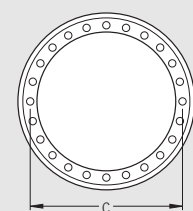

## TYPE 5 rolled plate

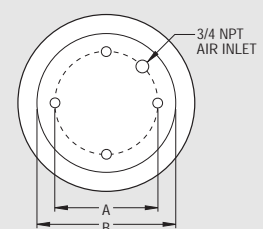

CONSULT FIRESTONE FOR USE AS AN AIRMOUNT

\*\*Airmount isolator air pressures below 40 PSIG should be reviewed with Firestone.  
 † Except for 1X84D-1 and 1M1A.

# 1M1A-0

# Firestone

# AIRSTROKE<sup>®</sup>

ACTUATORS

# AIRMOUNT<sup>®</sup>

ISOLATORS

Description		Assembly Order No.
Style 1M1A-0	Blind nut, 1/8 NPT, plastic stud	WO2-358-3000
Two Ply	Blind nut, 1/8 NPT, brass stud	WO2-358-3001
Bellows	Blind nut, 1/8 NPT, brass stud, stainless steel ring	WO2-358-3005
Assembly weight .....		0.5 lbs.
Force to collapse to minimum height (@ 0 PSIG) .....		20 lbs.

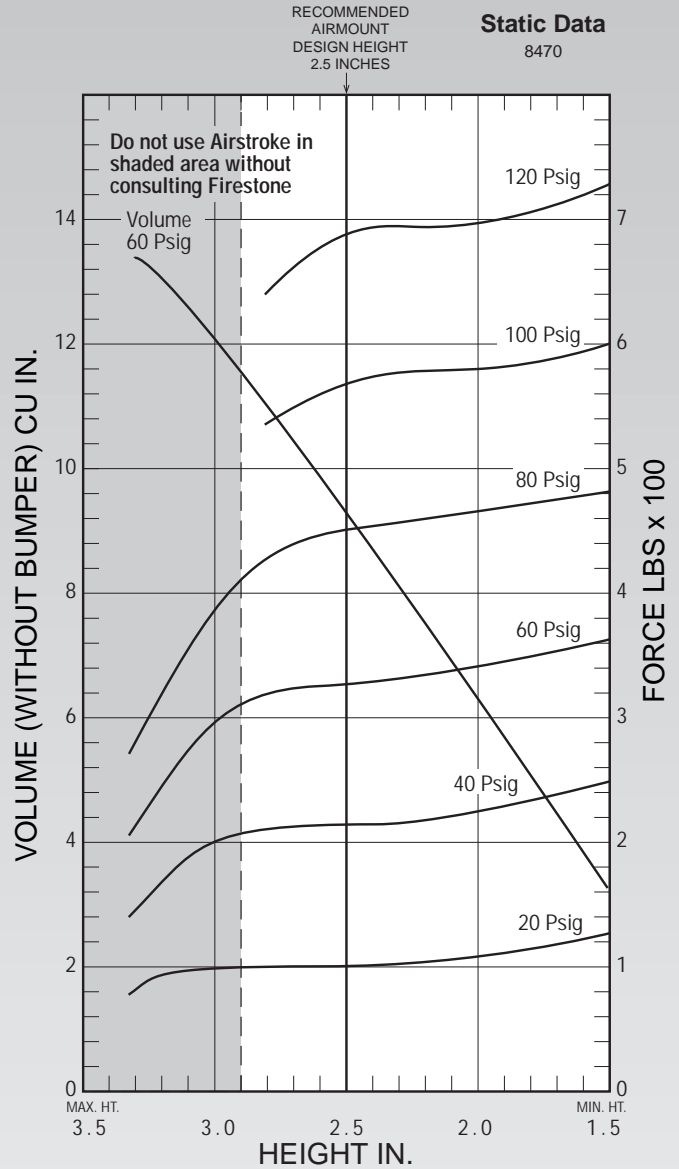
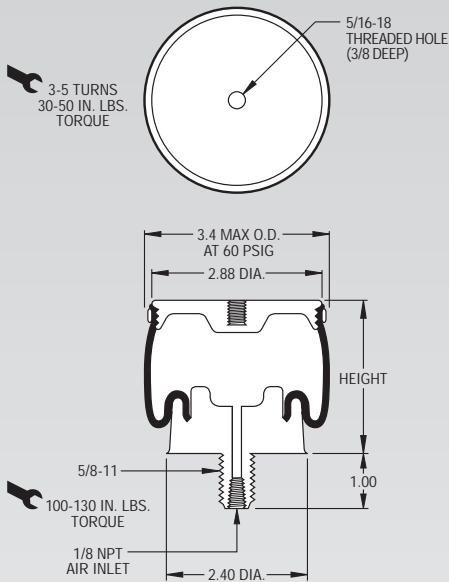

See page 12 for instructions on how to use chart.

Dynamic Characteristics at 2.5 in. Design Height (Required for Airmount isolator design only)				
Volume @ 60 PSIG = 9.2 in <sup>3</sup>			Natural Frequency	
Gage Pressure (PSIG)	Load (lbs.)	Spring Rate (lbs./in.)	CPM	HZ
40	210	336	235	3.92
60	330	467	224	3.73
80	450	619	220	3.67
100	570	740	214	3.57

Force Table (Use for Airstroke <sup>®</sup> actuator design)						
Assembly Height (in.)	Volume @ 60 PSIG (in <sup>3</sup> )	Pounds Force				
		@20 PSIG	@40 PSIG	@60 PSIG	@80 PSIG	@100 PSIG
2.0	6	110	230	340	460	580

Description		Assembly Order No.
Style 1M1A-1	Blind nut, 1/8 NPT, brass stud	WO2-358-3003
Two Ply Bellows		
Assembly weight .....		0.5 lbs.
Force to collapse to minimum height (@ 0 PSIG) .....		20 lbs.

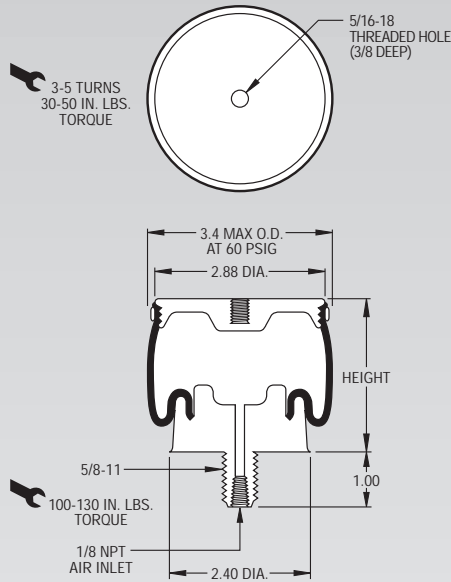

**NOTE:** The dotted line on the static data chart shows the force capabilities of the 1M1A-1 when attaching an additional 0.5 inch pedestal, provided by the customer, to the base of the air spring. If an additional pedestal is not used, the air spring will behave as the solid line depicts. Without a pedestal the rubber part will contact the ground at the height of 2.1 inches and could cause the rubber part to wear prematurely.

Dynamic Characteristics at 3.0 in. Design Height (Required for Airmount isolator design only)				
Volume @ 100 PSIG = 14 in <sup>3</sup>			Natural Frequency	
Gage Pressure (PSIG)	Load (lbs.)	Spring Rate (lbs./in.)	CPM	HZ
40	235	191	199.52	3.33
60	356	274	169.93	2.83
80	475	352	161.74	2.70
100	593	458	165.29	2.75

CONSULT FIRESTONE BEFORE USING AS AIRMOUNT  
RECOMMENDED AIRMOUNT DESIGN HEIGHT 3.0 INCHES  
**Static Data**  
B3940

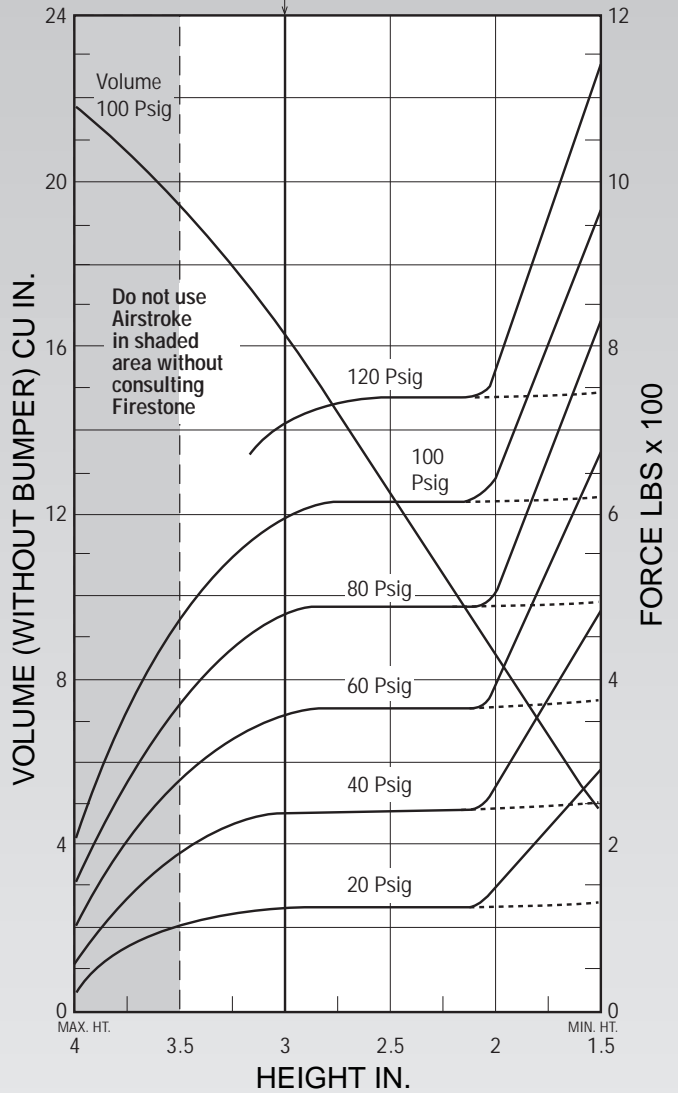

See page 12 for instructions on how to use chart.

Force Table (Use for Airstroke® actuator design)						
Assembly Height (in.)	Volume @ 100 PSIG (in <sup>3</sup> )	Pounds Force				
		@20 PSIG	@40 PSIG	@60 PSIG	@80 PSIG	@100 PSIG
3.0	14	118	235	356	475	593

### AIRSTROKE ACTUATOR ONLY

Description		Assembly Order No.
Style 2M1A	1/8 NPT, each end, plastic studs	WO2-358-3002
Two Ply Bellows	1/8 NPT, each end brass studs	WO2-358-3004
Assembly weight .....		0.6 lbs.
Force to collapse to minimum height (@ 0 PSIG).....		30 lbs.

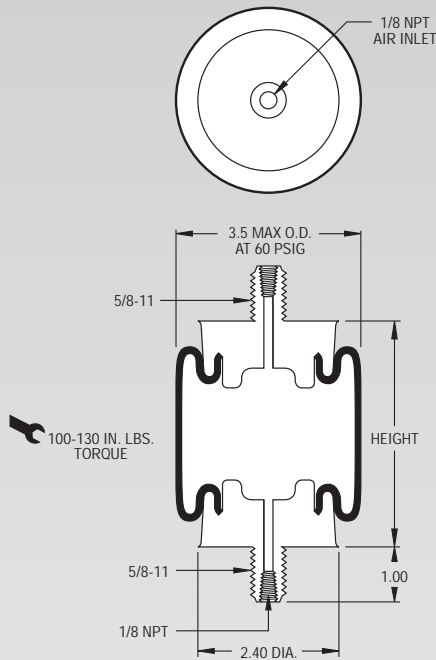

**NOTE:** This Airstroke actuator must be guided throughout the stroke.  
**NOTE:** Do not use as an Airmount isolator.  
**NOTE:** Plug off one end. (This part is single acting)

**NOTE:**  
**Do not use as an Airmount isolator.**

### Static Data

8469

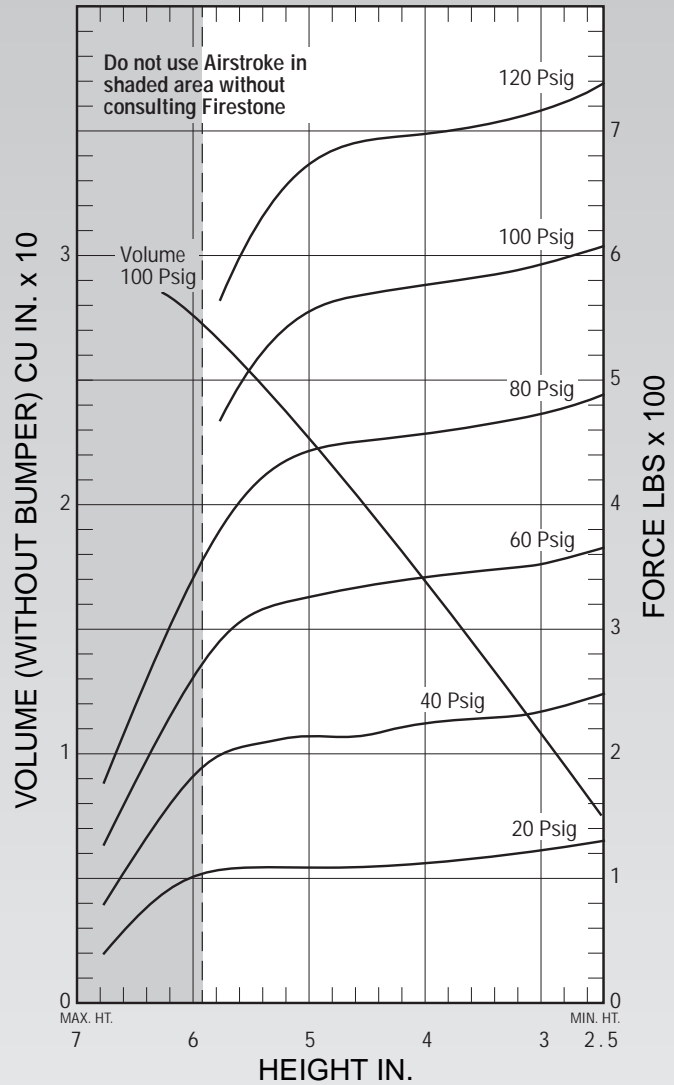

See page 12 for instructions on how to use chart.

Assembly Height (in.)	Volume @ 60 PSIG (in <sup>3</sup> )	Pounds Force				
		@20 PSIG	@40 PSIG	@60 PSIG	@80 PSIG	@100 PSIG
		6.0	28	100	180	270
5.0	23	110	210	330	440	560
4.0	17	120	230	340	460	580
3.0	11	120	240	350	480	600

Description		Assembly Order No.
Style 2M2A	Blind nut, 1/8 NPT, plastic studs	WO2-358-3008
Two Ply Bellows		
Assembly weight. . . . .		0.15 lbs.
Force to collapse to minimum height (@ 0 PSIG) . . .		5 lbs.

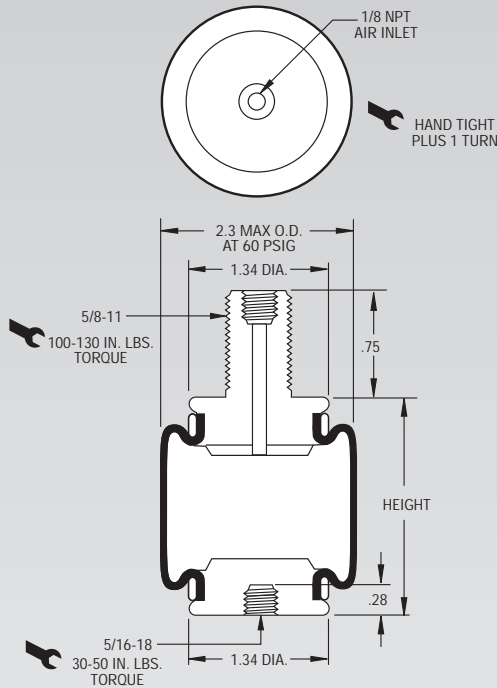

**NOTE:** This Airstroke actuator must be guided throughout the stroke.

**NOTE:** The 2M2A is laterally unstable when used unsupported as an isolator. Contact Firestone for use in isolation applications.

Dynamic Characteristics at 1.8 in. Design Height (Required for Airmount isolator design only)				
Volume @ 100 PSIG = 4.52 in <sup>3</sup>			Natural Frequency	
Gage Pressure (PSIG)	Load (lbs.)	Spring Rate (lbs./in.)	CPM	HZ
40	84	110	215	3.59
60	120	156	214	3.57
80	158	201	212	3.53
100	198	247	210	3.50

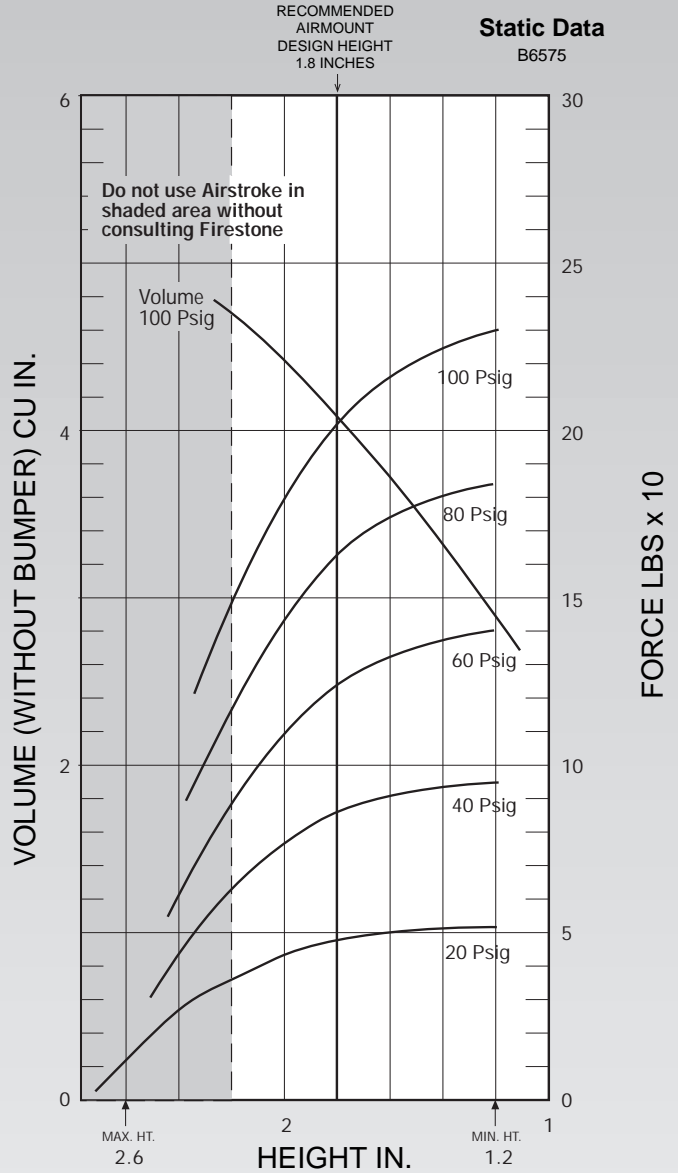

See page 12 for instructions on how to use chart.

Force Table (Use for Airstroke® actuator design)						
Assembly Height (in.)	Volume @ 60 PSIG (in <sup>3</sup> )	Pounds Force				
		@20 PSIG	@40 PSIG	@60 PSIG	@80 PSIG	@100 PSIG
1.2	2.92	52	94	138	184	229
1.4	3.36	50	92	135	180	224
1.6	3.78	48	89	130	172	214
1.8	4.17	46	84	120	158	198
2	4.52	41	73	105	137	172
2.2	4.79	34	58	84	108	138

Description		Assembly Order No.
Style 16	Blind nuts, 1/4 NPT	WO1-358-7001
	Blind nuts, 3/4 NPT	WO1-358-6996
Two Ply Bellows	Socket head aluminum bead rings (bolts, nuts, washers not included-use 1/4 cap screws)	WO1-358-0017
	3/4 NPT (only) upper plate, blind nuts lower plate	WO1-358-0286
	Rubber bellows only	WO1-358-0010
	Assembly weight .....	2.5 lbs.
Force to collapse to minimum height (@ 0 PSIG).....		30 lbs.

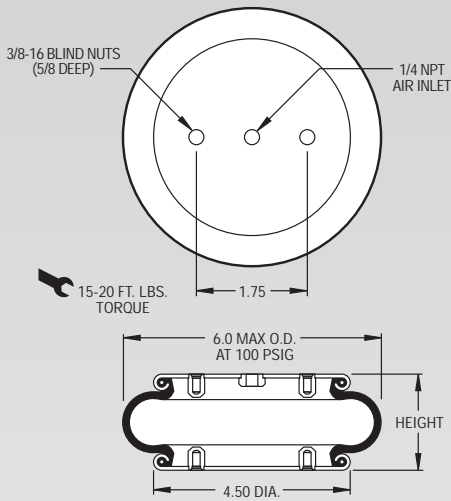

**NOTE: A bead plate part is shown. This part is also available with bead rings. Bolts are not included. See pages 8-10 for explanation.**

Dynamic Characteristics at 3.0 in. Design Height (Required for Airmount isolator design only)				
Volume @ 100 PSIG = 32 in <sup>3</sup>			Natural Frequency	
Gage Pressure (PSIG)	Load (lbs.)	Spring Rate (lbs./in.)	CPM	HZ
40	420	765	254	4.24
60	640	1,088	244	4.07
80	880	1,410	237	3.96
100	1,120	1,710	232	3.86

RECOMMENDED  
AIRMOUNT  
DESIGN HEIGHT  
3.0 INCHES

**Static Data**  
7559

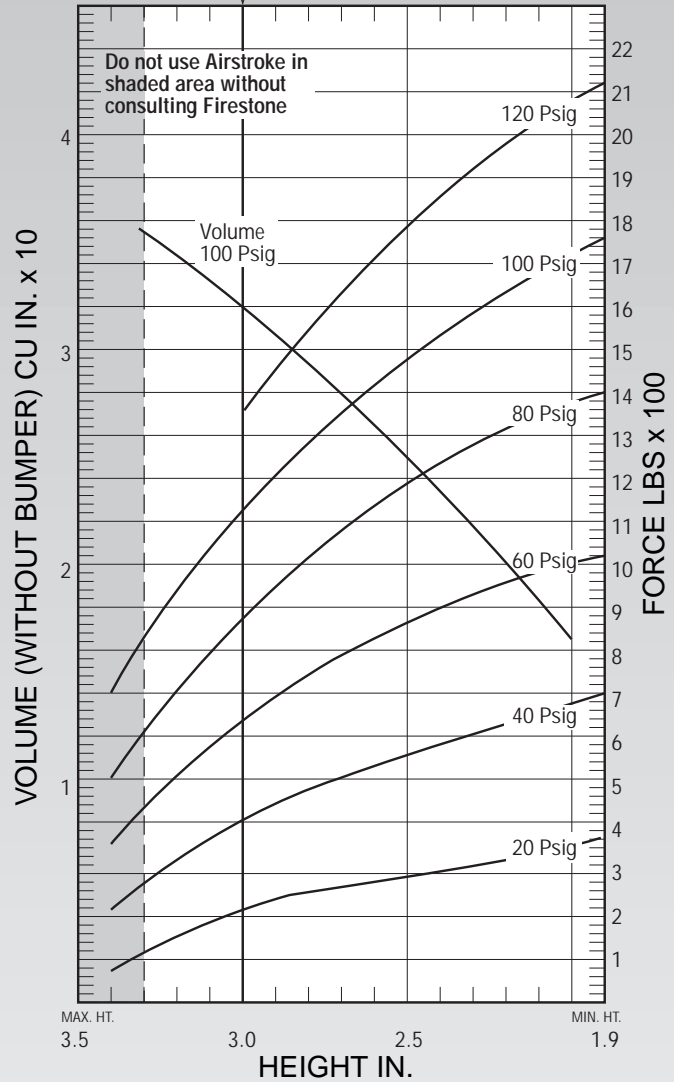

See page 12 for instructions on how to use chart.

Force Table (Use for Airstroke <sup>®</sup> actuator design)						
Assembly Height (in.)	Volume @ 100 PSIG (in <sup>3</sup> )	Pounds Force				
		@20 PSIG	@40 PSIG	@60 PSIG	@80 PSIG	@100 PSIG
3.0	32	220	420	640	880	1,120
2.0	17	350	680	1,020	1,370	1,720

Description		Assembly Order No.
Style 16-ST	Blind nuts, 1/4 NPT	WO2-358-5000
Two Ply Bellows	Stainless steel plates	WO2-358-5002
Assembly weight .....		1.25 lbs.
Force to collapse to minimum height (@ 0 PSIG).....		8.0 lbs.

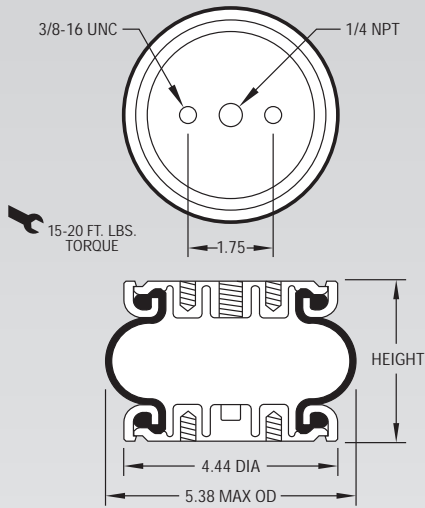

**NOTE:** The bellows extends beyond the bead plates at minimum height.

Dynamic Characteristics at 3.0 in. Design Height (Required for Airmount isolator design only)				
Volume @ 100 PSIG = 26.2 in <sup>3</sup>			Natural Frequency	
Gage Pressure (PSIG)	Load (lbs.)	Spring Rate (lbs./in.)	CPM	HZ
40	400	704	249	4.2
60	600	1,003	243	4.1
80	800	1,303	240	4.0
100	1,000	1,602	238	4.0

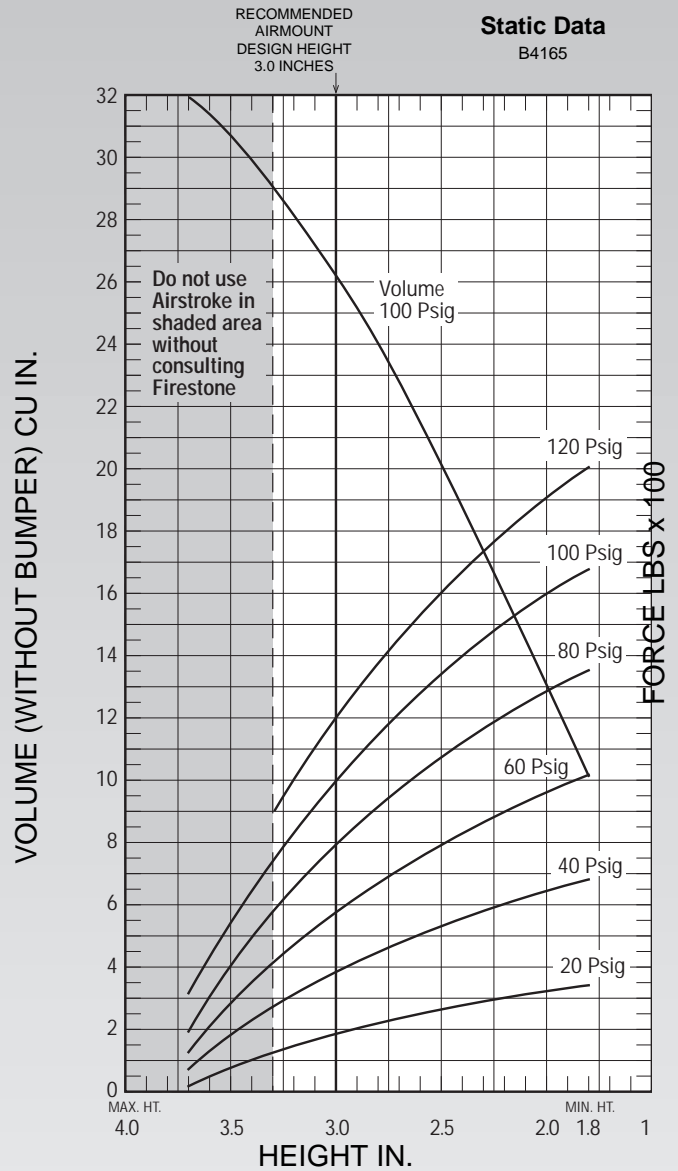

See page 12 for instructions on how to use chart.

Force Table (Use for Airstroke® actuator design)						
Assembly Height (in.)	Volume @ 100 PSIG (in <sup>3</sup> )	Pounds Force				
		@20 PSIG	@40 PSIG	@60 PSIG	@80 PSIG	@100 PSIG
3.3	29.0	130	270	410	590	780
3.0	26.2	200	400	600	800	1,000
2.5	20.0	270	530	800	1,070	1,330
2.0	12.5	320	640	960	1,280	1,600
1.8	10.0	340	670	1,010	1,350	1,680

Description		Assembly Order No.
Style 131	Blind nuts, 1/4 NPT	WO1-358-7731
	Blind nuts, 3/4 NPT	WO1-358-7742
Two Ply Bellows	Socket head aluminum bead rings (bolts, nuts, washers not included-use 1/4 cap screws)	WO1-358-0127
	3/4 NPT (only) upper plate, blind nuts lower plate	WO1-358-7729
	Rubber bellows only	WO1-358-0131
	Assembly weight .....	2.8 lbs.
Force to collapse to minimum height (@ 0 PSIG).....		32 lbs.

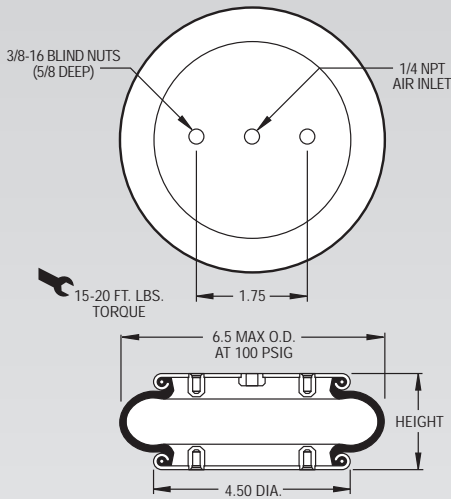

**NOTE: A bead plate part is shown. This part is also available with bead rings. Bolts are not included. See pages 8-10 for explanation.**

Dynamic Characteristics at 3.5 in. Design Height (Required for Airmount isolator design only)				
Volume @ 100 PSIG = 53 in <sup>3</sup>			Natural Frequency	
Gage Pressure (PSIG)	Load (lbs.)	Spring Rate (lbs./in.)	CPM	HZ
40	550	587	195	3.25
60	850	833	186	3.09
80	1,170	1,082	181	3.01
100	1,510	1,331	176	2.94

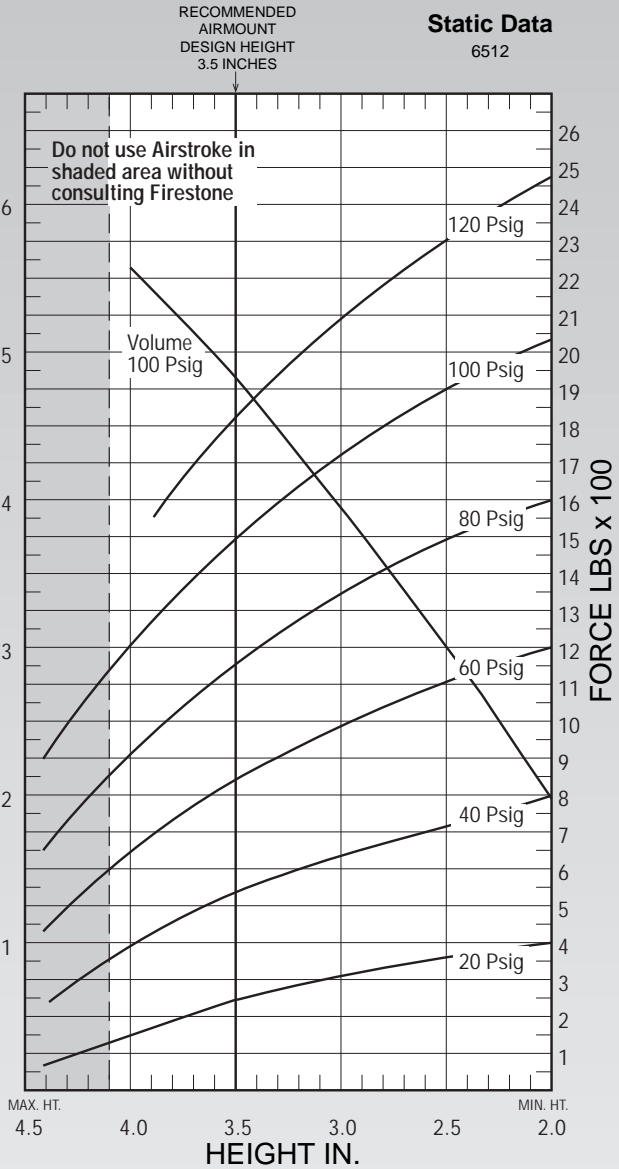

See page 12 for instructions on how to use chart.

Force Table (Use for Airstroke <sup>®</sup> actuator design)						
Assembly Height (in.)	Volume @ 100 PSIG (in <sup>3</sup> )	Pounds Force				
		@20 PSIG	@40 PSIG	@60 PSIG	@80 PSIG	@100 PSIG
4.0	56	160	400	650	910	1,210
3.0	39	310	640	990	1,350	1,730
2.0	20	390	790	1,200	1,600	2,050



Description		Assembly Order No.
Style 110	Blind nuts, 1/4 NPT	WO1-358-7451
	Blind nuts, 3/4 NPT	WO1-358-7484
Two Ply Bellows	Socket head aluminum bead rings (bolts, nuts, washers not included-use 1/4 cap screws)	WO1-358-0112
	Rubber bellows only	WO1-358-0100
Assembly weight .....		3.0 lbs.
Force to collapse to minimum height (@ 0 PSIG).....		8 lbs.

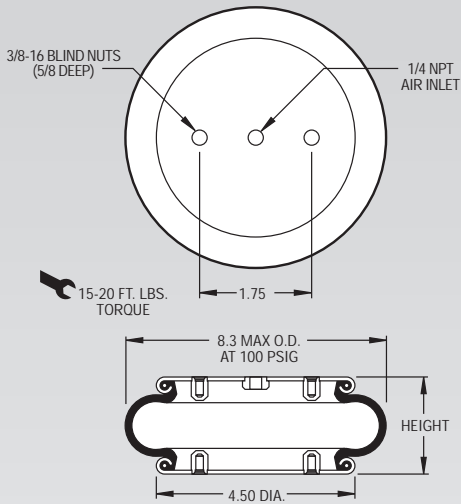

**NOTE: A bead plate part is shown. This part is also available with bead rings. Bolts are not included. See pages 8-10 for explanation.**

Dynamic Characteristics at 4.5 in. Design Height (Required for Airmount isolator design only)				
Volume @ 100 PSIG = 128 in <sup>3</sup>			Natural Frequency	
Gage Pressure (PSIG)	Load (lbs.)	Spring Rate (lbs./in.)	CPM	HZ
40	650	554	173	2.88
60	1,010	795	167	2.77
80	1,390	1,046	162	2.71
100	1,790	1,294	160	2.66

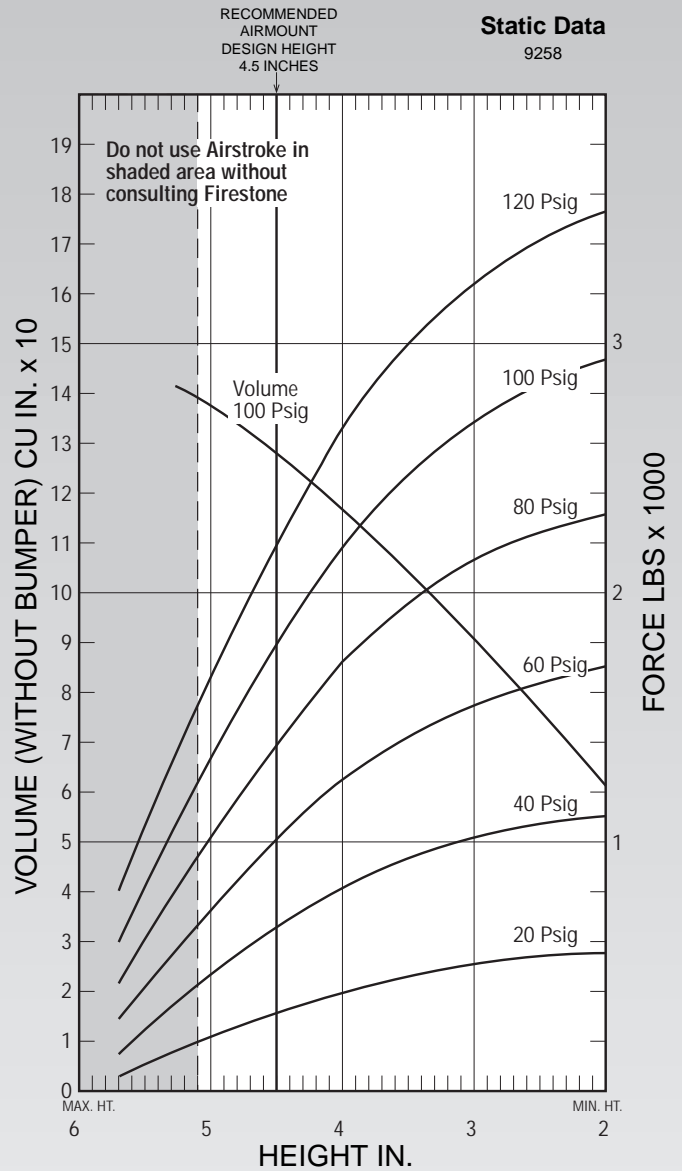

See page 12 for instructions on how to use chart.

Force Table (Use for Airstroke® actuator design)						
Assembly Height (in.)	Volume @ 100 PSIG (in <sup>3</sup> )	Pounds Force				
		@20 PSIG	@40 PSIG	@60 PSIG	@80 PSIG	@100 PSIG
4.0	117	390	810	1,240	1,700	2,160
3.0	91	490	1,010	1,540	2,090	2,650

Description		Assembly Order No.
Style 116	Blind nuts, 1/4 NPT	WO1-358-7564
	Blind nuts, 3/4 NPT	WO1-358-7561
Two Ply Bellows	Button head steel bead rings, 1 <sup>5</sup> / <sub>8</sub> bolts, nuts, washers	WO1-358-7568
	Blind nuts with installed 1/4 tank valve	WO1-A72-7518
	Rubber bellows only	WO1-358-0133

Assembly weight ..... 4.3 lbs.

Force to collapse to minimum height (@ 0 PSIG)..... 8 lbs.

Style 117	Blind nuts, 1/4 NPT	WO1-358-7600
	Blind nuts, 3/4 NPT	WO1-358-7602
High Strength Bellows	Button head steel bead rings, 1 <sup>7</sup> / <sub>8</sub> bolts, nuts, washers	WO1-358-7606

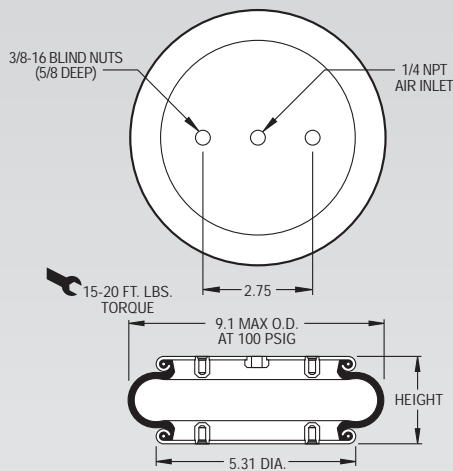

**NOTE: A bead plate part is shown. This part is also available with bead rings. See pages 8-10 for explanation.**

Dynamic Characteristics at 4.5 in. Design Height (Required for Airmount isolator design only)				
Volume @ 100 PSIG = 149 in <sup>3</sup>			Natural Frequency	
Gage Pressure (PSIG)	Load (lbs.)	Spring Rate (lbs./in.)	CPM	HZ
40	850	736	175	2.91
60	1,330	1,070	168	2.80
80	1,830	1,374	163	2.71
100	2,360	1,688	159	2.65

RECOMMENDED  
AIRMOUNT  
DESIGN HEIGHT  
4.5 INCHES

**Static Data**  
7557

VOLUME (WITHOUT BUMPER) CU IN. x 10

FORCE LBS x 1000

HEIGHT IN.

See page 12 for instructions on how to use chart.

Force Table (Use for Airstroke <sup>®</sup> actuator design)						
Assembly Height (in.)	Volume @ 100 PSIG (in <sup>3</sup> )	Pounds Force				
		@20 PSIG	@40 PSIG	@60 PSIG	@80 PSIG	@100 PSIG
5.0	161	290	600	970	1,370	1,800
4.0	135	520	1,050	1,630	2,210	2,820
3.0	102	650	1,310	2,000	2,690	3,410

Description		Assembly Order No.
Style 116-1	Blind nuts, 1/4 NPT	WO1-358-7598
	Blind nuts, 3/4 NPT	WO1-358-7605
Two Ply Bellows		
Assembly weight .....		4.5 lbs.
Force to collapse to minimum height (@ 0 PSIG).....		37 lbs.

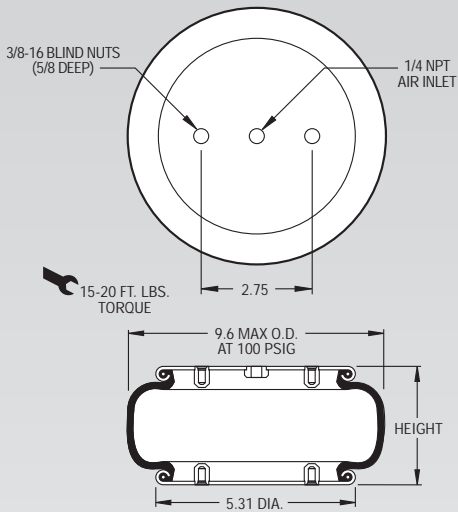

**NOTE: A bead plate part is shown. This part is also available with bead rings. See pages 8-10 for explanation.**

Dynamic Characteristics at 5.5 in. Design Height (Required for Airmount isolator design only)				
Volume @ 100 PSIG = 225 in <sup>3</sup>			Natural Frequency	
Gage Pressure (PSIG)	Load (lbs.)	Spring Rate (lbs./in.)	CPM	HZ
40	940	564	145	2.42
60	1,410	803	141	2.36
80	1,930	1,054	139	2.31
100	2,530	1,327	136	2.26

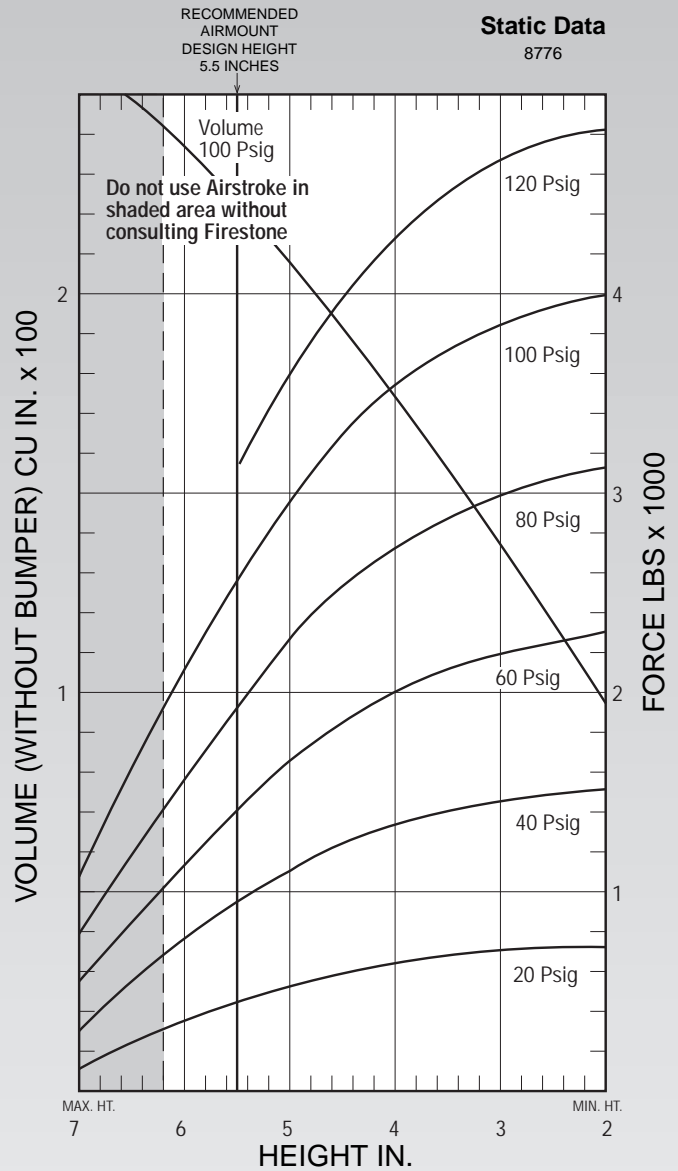

See page 12 for instructions on how to use chart.

Force Table (Use for Airstroke® actuator design)						
Assembly Height (in.)	Volume @ 100 PSIG (in <sup>3</sup> )	Pounds Force				
		@20 PSIG	@40 PSIG	@60 PSIG	@80 PSIG	@100 PSIG
6.0	237	360	750	1,150	1,580	2,090
5.0	210	540	1,100	1,650	2,240	2,920
4.0	178	650	1,330	2,000	2,710	3,490
3.0	139	710	1,450	2,200	2,980	3,810

Description		Assembly Order No.
Style 115	Blind nuts, 1/4 NPT	WO1-358-7460
	Blind nuts, 1/4 NPT rubber bumper	WO1-358-7459
Two Ply Bellows	Blind nuts, 3/4 NPT	WO1-358-7465
	Blind nuts, 3/4 NPT rubber bumper	WO1-358-7458
	Countersunk steel bead rings, 1 5/8 bolts, nuts, washers	WO1-358-7469
	Blind nuts, 3/4 NPT both ends (centered)	WO1-606-7115
	Rubber bellows only	WO1-358-0118
Assembly weight .....		5.5 lbs.
Force to collapse to minimum height (@ 0 PSIG).....		8 lbs.

Style 124 High Strength Bellows	Blind nuts, 1/4 NPT	WO1-358-7650
	Blind nuts, 3/4 NPT	WO1-358-7649

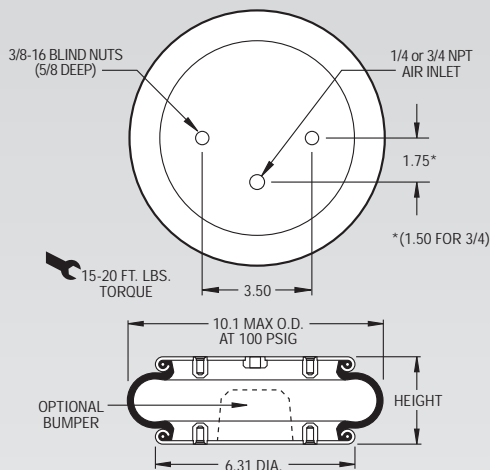

**NOTE: A bead plate part is shown. This part is also available with bead rings. See pages 8-10 for explanation.**

Dynamic Characteristics at 4.5 in. Design Height (Required for Airmount isolator design only)				
Volume @ 100 PSIG = 192 in <sup>3</sup>			Natural Frequency	
Gage Pressure (PSIG)	Load (lbs.)	Spring Rate (lbs./in.)	CPM	HZ
40	1,180	1,008	174	2.89
60	1,750	1,417	169	2.81
80	2,350	1,846	166	2.77
100	3,010	2,257	163	2.71

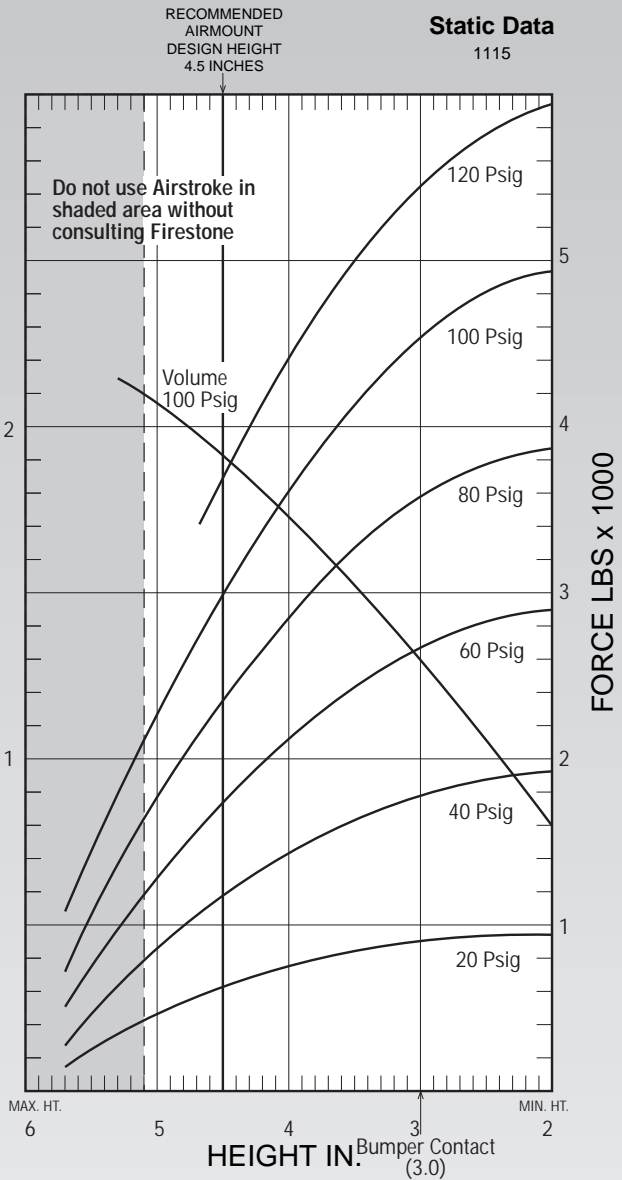

See page 12 for instructions on how to use chart.

Force Table (Use for Airstroke <sup>®</sup> actuator design)						
Assembly Height (in.)	Volume @ 100 PSIG (in <sup>3</sup> )	Pounds Force				
		@20 PSIG	@40 PSIG	@60 PSIG	@80 PSIG	@100 PSIG
5.0	207	460	840	1,290	1,730	2,270
4.0	173	740	1,440	2,150	2,870	3,640
3.0	130	890	1,760	2,650	3,550	4,520

Description		Assembly Order No.
Style 19	Blind nuts, 1/4 NPT	WO1-358-7008
	Blind nuts, 1/4 NPT, bumper	WO1-358-7009
Two Ply Bellows	Blind nuts, 3/4 NPT	WO1-358-7011
	Blind nuts, 3/4 NPT, bumper	WO1-358-7012
	Countersunk steel bead rings, 1 <sup>5</sup> / <sub>8</sub> bolts, nuts, washers	WO1-358-7023
	Rubber bellows only	WO1-358-0134
Assembly weight .....		9.8 lbs.
Force to collapse to minimum height (@ 0 PSIG).....		9 lbs.

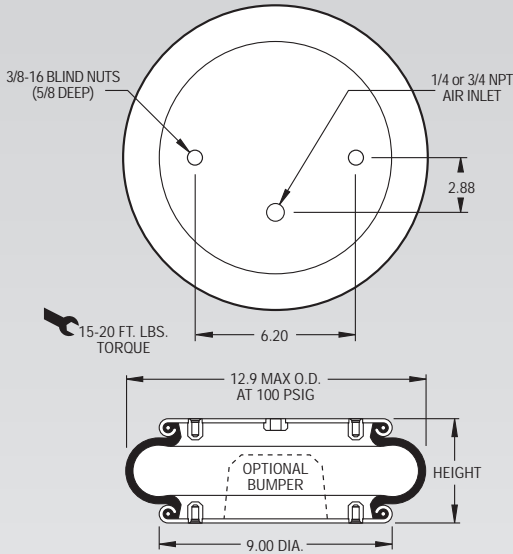

**NOTE: A bead plate part is shown. This part is also available with bead rings. See pages 8-10 for explanation.**

Dynamic Characteristics at 5.0 in. Design Height (Required for Airmount isolator design only)				
Volume @ 100 PSIG = 384 in <sup>3</sup>			Natural Frequency	
Gage Pressure (PSIG)	Load (lbs.)	Spring Rate (lbs./in.)	CPM	HZ
40	2,130	1,670	166	2.77
60	3,310	2,379	159	2.65
80	4,500	3,112	156	2.60
100	5,680	3,778	153	2.55

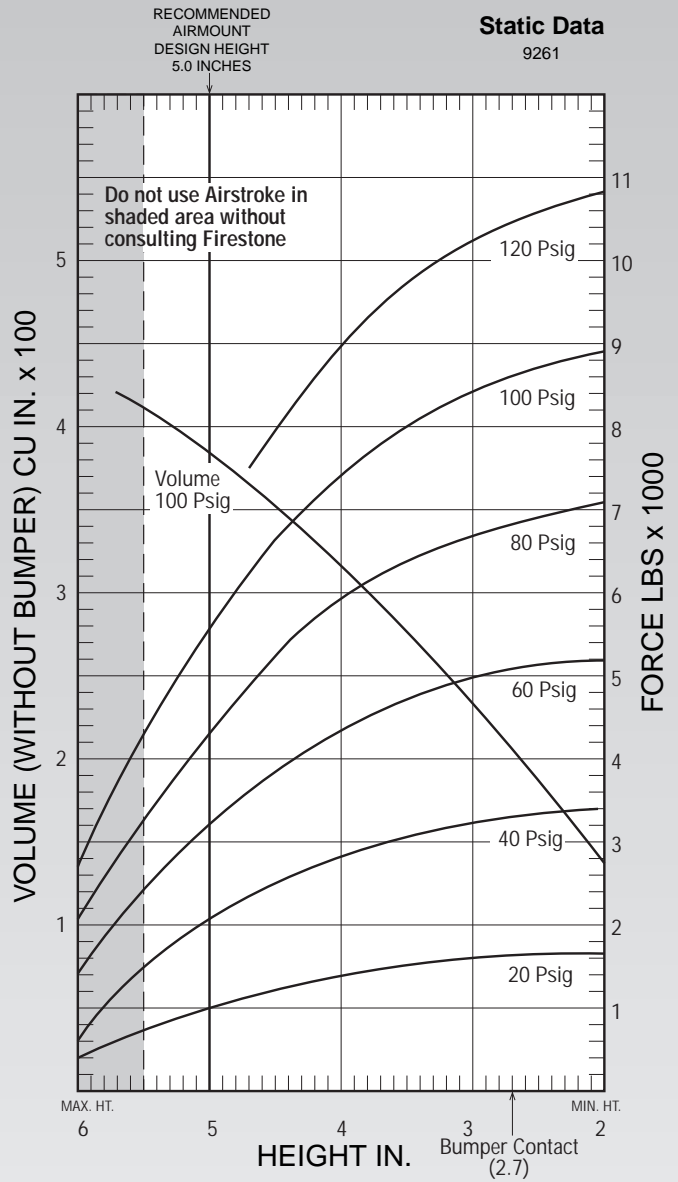

See page 12 for instructions on how to use chart.

Force Table (Use for Airstroke® actuator design)						
Assembly Height (in.)	Volume @ 100 PSIG (in <sup>3</sup> )	Pounds Force				
		@20 PSIG	@40 PSIG	@60 PSIG	@80 PSIG	@100 PSIG
5.0	384	1,050	2,130	3,310	4,500	5,680
4.0	315	1,410	2,880	4,410	5,950	7,460
3.0	232	1,580	3,280	5,000	6,720	8,440

# 19-.75

# Firestone

# AIRSTROKE<sup>®</sup>

ACTUATORS

# AIRMOUNT<sup>®</sup>

ISOLATORS

Description		Assembly Order No.
Style 19-.75	Blind nuts, 1/4 NPT	WO1-358-7040
	Blind nuts, 1/4 NPT rubber bumper	WO1-358-7039
Two Ply Bellows	Blind nuts, 3/4 NPT	WO1-358-7042
	Blind nuts, 3/4 NPT rubber bumper	WO1-358-7043
Assembly weight .....		10.0 lbs.
Force to collapse to minimum height (@ 0 PSIG).....		15 lbs.

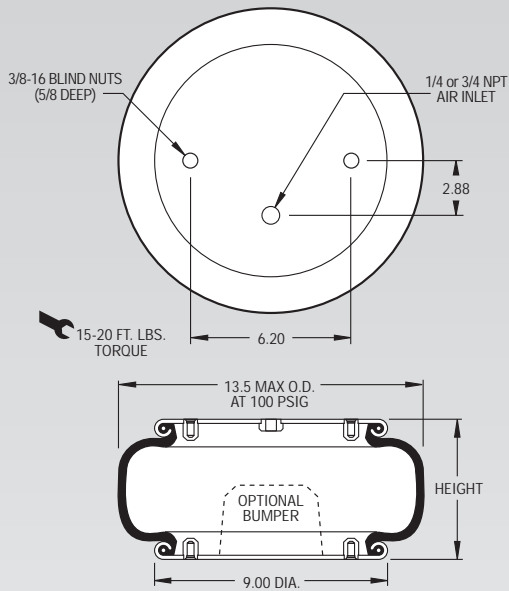

**NOTE: A bead plate part is shown. This part is also available with bead rings. See pages 8-10 for explanation.**

Dynamic Characteristics at 5.5 in. Design Height (Required for Airmount isolator design only)				
Volume @ 100 PSIG = 470 in <sup>3</sup>			Natural Frequency	
Gage Pressure (PSIG)	Load (lbs.)	Spring Rate (lbs./in.)	CPM	HZ
40	1,890	1,544	170	2.83
60	2,950	2,203	162	2.70
80	4,080	2,829	156	2.60
100	5,260	3,448	152	2.53

RECOMMENDED AIRMOUNT DESIGN HEIGHT 5.5 INCHES

**Static Data**  
4043

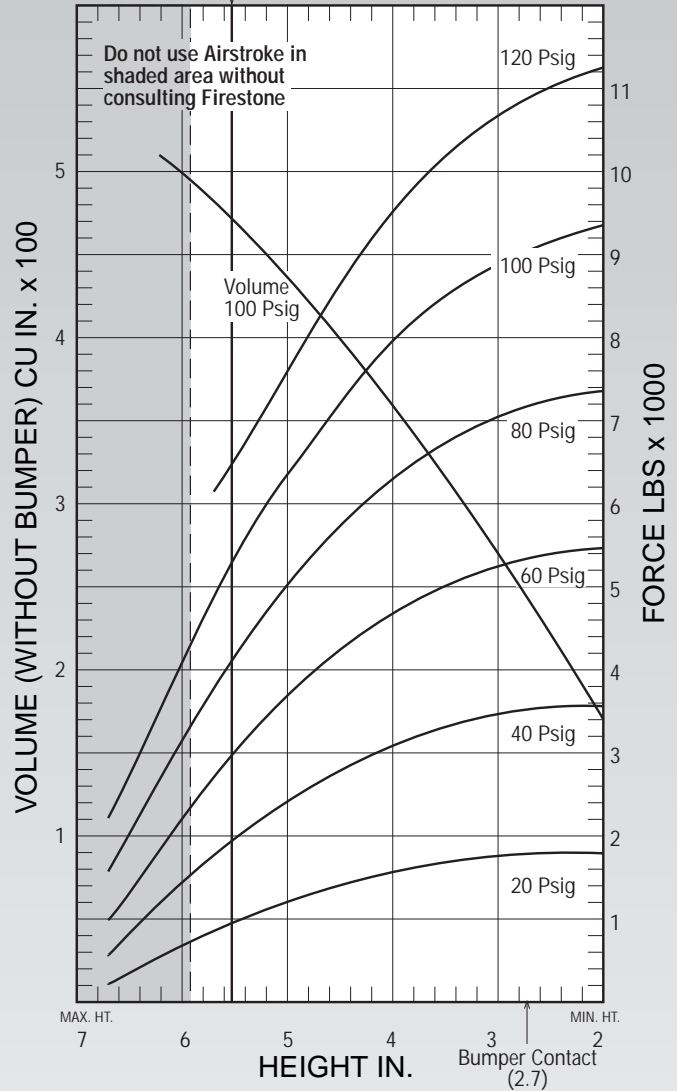

See page 12 for instructions on how to use chart.

Force Table (Use for Airstroke <sup>®</sup> actuator design)						
Assembly Height (in.)	Volume @ 100 PSIG (in <sup>3</sup> )	Pounds Force				
		@20 PSIG	@40 PSIG	@60 PSIG	@80 PSIG	@100 PSIG
5.0	438	1,190	2,390	3,670	5,000	6,360
4.0	359	1,560	3,110	4,710	6,330	7,980
3.0	270	1,730	3,460	5,240	7,040	8,850

Description		Assembly Order No.
Style 113	Blind nuts, 1/4 NPT	WO1-358-7103
	Blind nuts, 1/4 NPT, bumper	WO1-358-7104
Two Ply Bellows	Blind nuts, 3/4 NPT	WO1-358-7101
	Blind nuts, 3/4 NPT, bumper	WO1-358-7109
	Button head steel bead rings, 1 7/8 bolts, nuts, washers	WO1-358-7110
	Blind nuts, 1/8 NPT	WO1-753-7113
	Blind nuts, 1 1/4 NPT	WO1-753-7114
	Rubber bellows only	WO1-358-0135

Assembly weight ..... 14.5 lbs.

Force to collapse to minimum height (@ 0 PSIG)..... 17 lbs.

Style 128	Blind nuts, 1/4 NPT	WO1-358-8151
	Blind nuts, 1/4 NPT, rubber bumper	WO1-358-8149
High Strength Bellows	Blind nuts, 3/4 NPT	WO1-358-8152
	Blind nuts, 3/4 NPT, rubber bumper	WO1-358-8150
	Rubber bellows only	WO1-358-0231

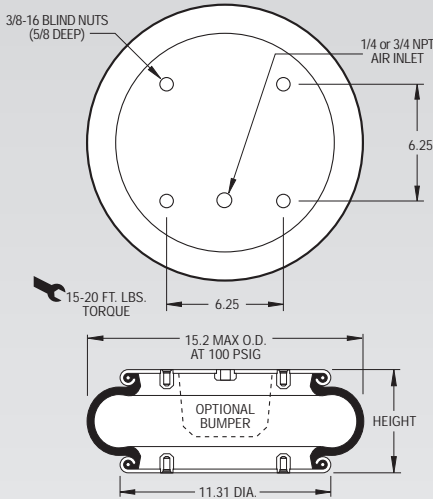

**NOTE: A bead plate part is shown. This part is also available with bead rings. See pages 8-10 for explanation.**

Dynamic Characteristics at 5.0 in. Design Height (Required for Airmount isolator design only)				
Volume @ 100 PSIG = 585 in <sup>3</sup>			Natural Frequency	
Gage Pressure (PSIG)	Load (lbs.)	Spring Rate (lbs./in.)	CPM	HZ
40	3,220	2,429	163	2.72
60	5,030	3,432	155	2.58
80	6,890	4,407	150	2.50
100	8,800	5,385	147	2.45

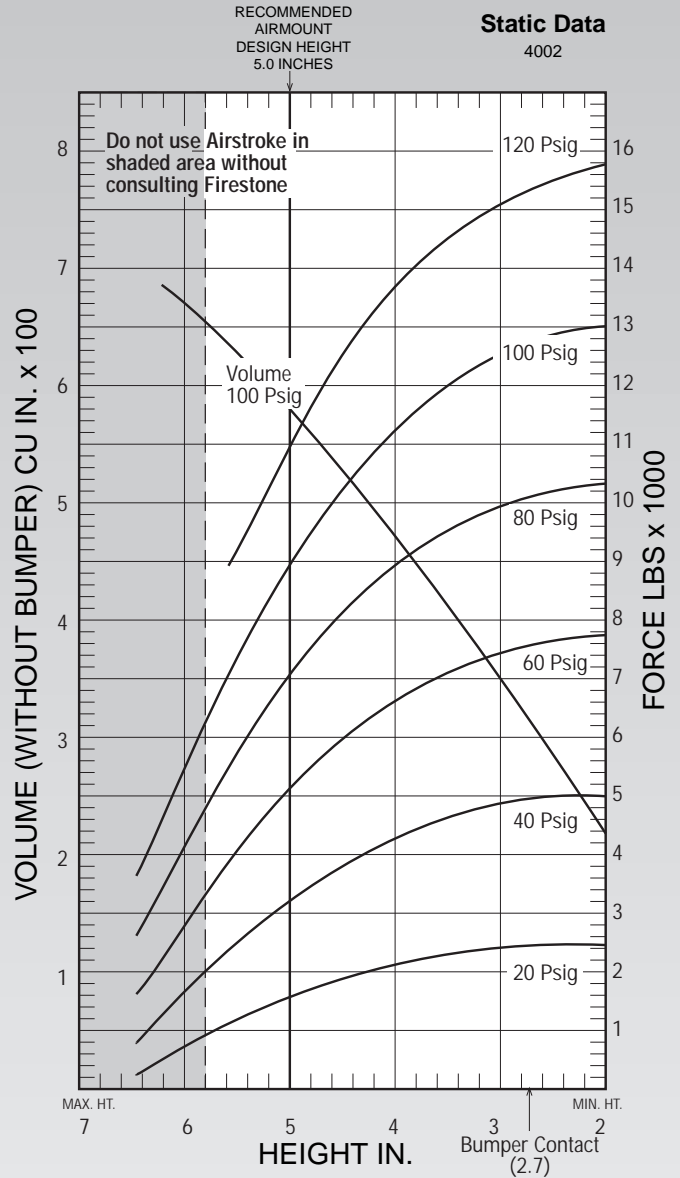

See page 12 for instructions on how to use chart.

Force Table (Use for Airstroke® actuator design)						
Assembly Height (in.)	Volume @ 100 PSIG (in <sup>3</sup> )	Pounds Force				
		@20 PSIG	@40 PSIG	@60 PSIG	@80 PSIG	@100 PSIG
5.0	585	1,540	3,220	5,030	6,890	8,800
4.0	477	2,120	4,320	6,600	8,890	11,230
3.0	353	2,390	4,830	7,380	9,900	12,470

Description		Assembly Order No.
Style 113-1	Blind nuts, 1/4 NPT	WO1-358-7091
	Blind nuts, 3/4 NPT	WO1-358-7092
Two Ply Bellows	Blind nuts, 3/4 NPT, rubber bumper	WO1-358-7094
	Button head steel bead rings, 1 7/8 bolts, nuts, washers	WO1-358-7277
	Rubber bellows only	WO1-358-0150

Assembly weight ..... 15.2 lbs.  
 Force to collapse to minimum height (@ 0 PSIG)..... 25 lbs.

Style 128-1	Blind nuts, 3/4 NPT	WO1-358-8160
High Strength Bellows		

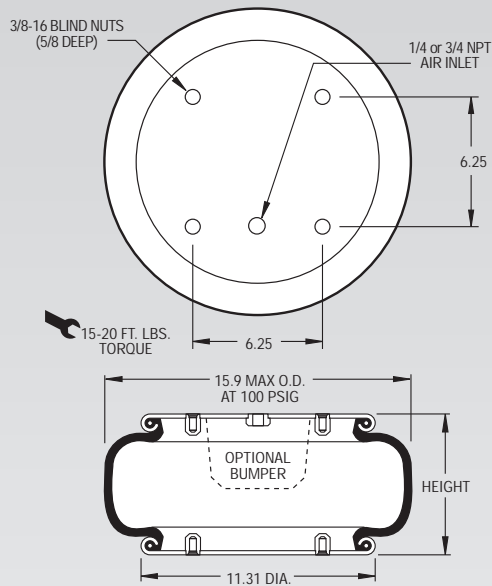

**NOTE: A bead plate part is shown. This part is also available with bead rings. See pages 8-10 for explanation.**

Dynamic Characteristics at 5.5 in. Design Height (Required for Airmount isolator design only)				
Volume @ 100 PSIG = 641 in <sup>3</sup>			Natural Frequency	
Gage Pressure (PSIG)	Load (lbs.)	Spring Rate (lbs./in.)	CPM	HZ
40	3,820	2,198	142	2.37
60	5,900	3,091	136	2.26
80	7,990	3,986	133	2.21
100	10,200	4,923	130	2.17

RECOMMENDED  
AIRMOUNT  
DESIGN HEIGHT  
5.5 INCHES

Static Data  
A8915

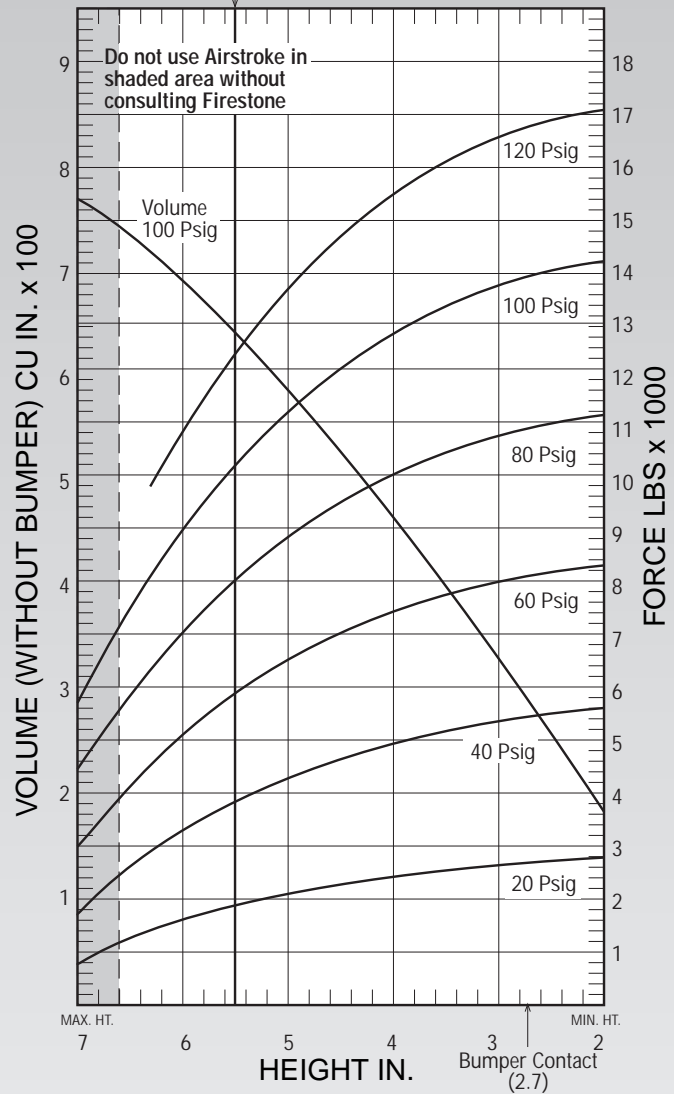

See page 12 for instructions on how to use chart.

Force Table (Use for Airstroke <sup>®</sup> actuator design)						
Assembly Height (in.)	Volume @ 100 PSIG (in <sup>3</sup> )	Pounds Force				
		@20 PSIG	@40 PSIG	@60 PSIG	@80 PSIG	@100 PSIG
6.0	692	1,600	3,270	5,130	7,000	8,990
5.0	586	2,070	4,260	6,530	8,800	11,200
4.0	463	2,440	4,940	7,470	10,080	12,710
3.0	328	2,660	5,360	8,060	10,860	13,630



Description		Assembly Order No.
Style 153-2	Blind nuts, 1/4 NPT Blind nuts, 3/4 NPT	WO1-358-8158 WO1-358-8157
Two Ply Bellows		
Assembly weight .....		17.1 lbs.

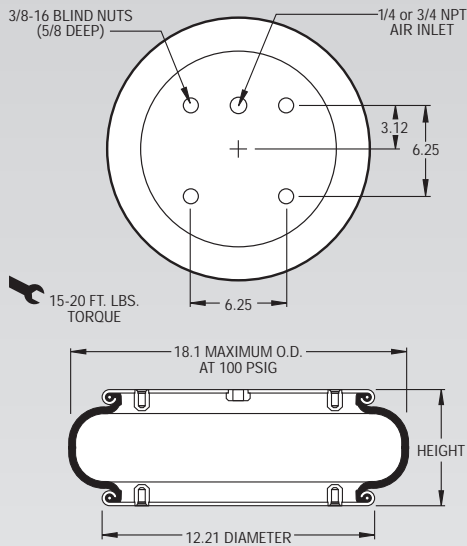

**NOTE: A bead plate part is shown. This part is also available with bead rings. See pages 8-10 for explanation.**

Dynamic Characteristics at 6.0 in. Design Height (Required for Airmount isolator design only)				
Volume @ 100 PSIG = 981 in <sup>3</sup>			Natural Frequency	
Gage Pressure (PSIG)	Load (lbs.)	Spring Rate (lbs./in.)	CPM	HZ
40	4,564	2,202	131	2.18
60	7,048	3,153	126	2.10
80	9,682	4,031	121	2.02
100	12,385	4,958	119	1.98

CONSULT FIRESTONE BEFORE USING AS AIRMOUNT

RECOMMENDED AIRMOUNT DESIGN HEIGHT 6.0 INCHES

**Static Data**  
B4561

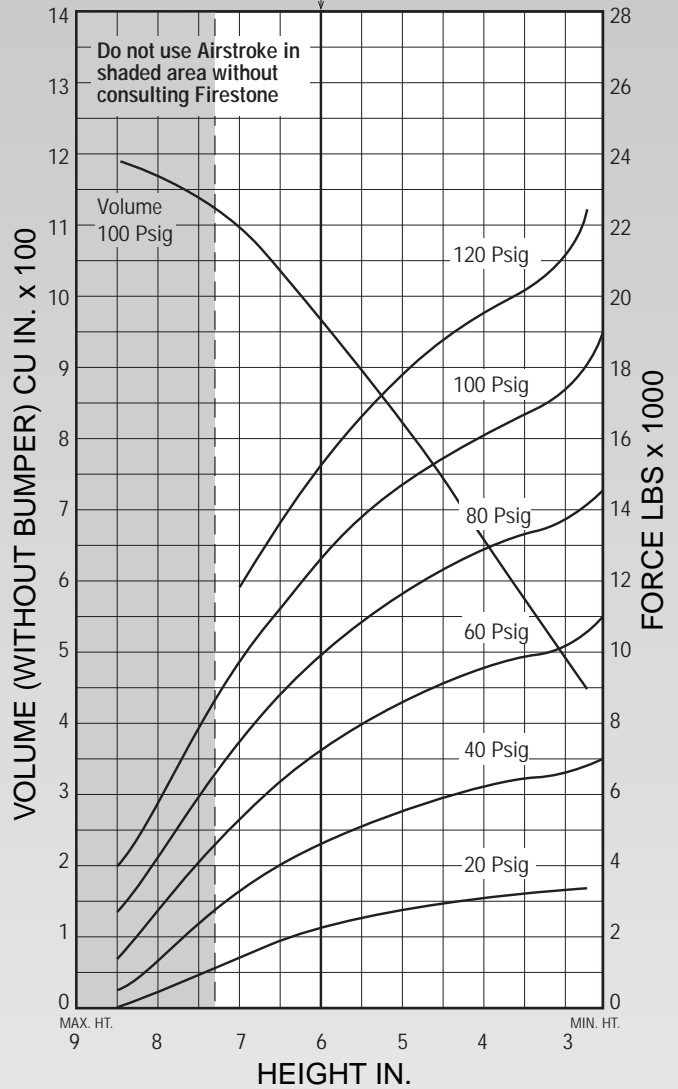

See page 12 for instructions on how to use chart.

Force Table (Use for Airstroke® actuator design)						
Assembly Height (in.)	Volume @ 100 PSIG (in <sup>3</sup> )	Pounds Force				
		@20 PSIG	@40 PSIG	@60 PSIG	@80 PSIG	@100 PSIG
8.0	1,169	425	1,260	2,566	4,038	5,636
7.0	1,094	1,423	3,210	5,194	7,334	9,528
6.0	981	2,140	4,564	7,048	9,682	12,385
5.0	840	2,676	5,476	8,458	11,440	14,471
4.0	679	3,051	6,153	9,478	12,738	15,965
3.0	510	3,219	6,609	10,069	13,550	17,218

Description		Assembly Order No.
Style 119	Ribbed neck aluminum bead rings (equal spacing), 1 7/8 bolts, nuts, washers	WO1-358-7478
Two Ply Bellows	Rubber bellows only	WO1-358-0119
	Rolled Plate Assembly, 1/2 blind nuts, 3/4 NPT	WO1-358-7477
Assembly weight .....		13.2 lbs.
Force to collapse to minimum height (@ 0 PSIG).....		17 lbs.

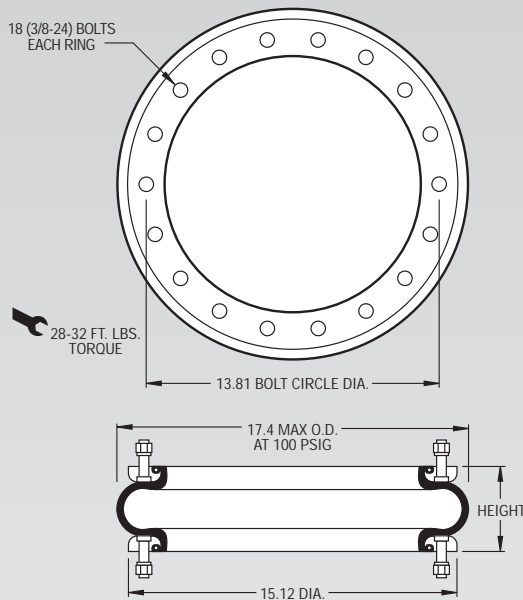

**NOTE: A bead plate part is shown. This part is also available with rolled plates. See page 11 for explanation.**

Dynamic Characteristics at 5.0 in. Design Height (Required for Airmount isolator design only)				
Volume @ 100 PSIG = 787 in <sup>3</sup>			Natural Frequency	
Gage Pressure (PSIG)	Load (lbs.)	Spring Rate (lbs./in.)	CPM	HZ
40	5,490	3,478	149	2.49
60	8,450	4,880	143	2.38
80	11,450	6,186	138	2.30
100	14,520	7,523	135	2.25

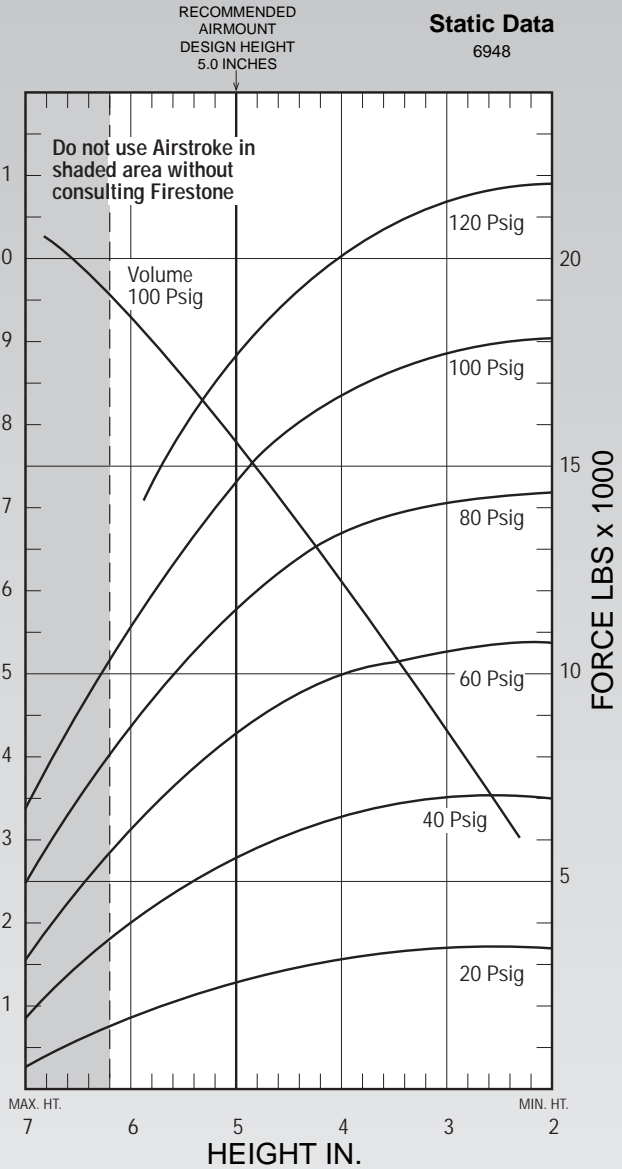

See page 12 for instructions on how to use chart.

Force Table (Use for Airstroke <sup>®</sup> actuator design)						
Assembly Height (in.)	Volume @ 100 PSIG (in <sup>3</sup> )	Pounds Force				
		@20 PSIG	@40 PSIG	@60 PSIG	@80 PSIG	@100 PSIG
6.0	932	1,640	3,800	6,100	8,550	11,070
5.0	787	2,560	5,490	8,450	11,450	14,520
4.0	617	3,080	6,470	9,850	13,190	16,600
3.0	436	3,310	6,920	10,530	14,030	17,630

Description		Assembly Order No.
Style 121	Ribbed neck aluminum bead rings, 1 7/8 bolts, nuts, washers	WO1-358-7197
Two Ply	Rubber bellows only	WO1-358-5135
Bellows	Rolled Plate Assembly, 1/2 blind nuts, 3/4 NPT	WO1-358-7272
Assembly weight .....		16.5 lbs.
Force to collapse to minimum height (@ 0 PSIG).....		20 lbs.

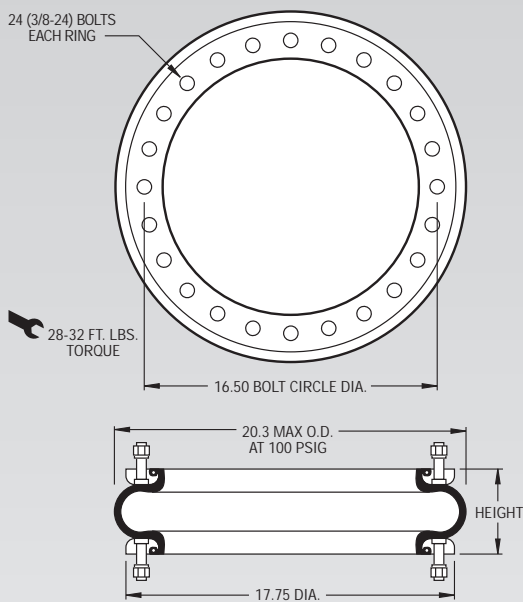

**NOTE:** A bead ring part is shown. This part is also available with rolled plates. See page 11 for explanation.

Dynamic Characteristics at 5.0 in. Design Height (Required for Airmount isolator design only)				
Volume @ 100 PSIG = 1,154 in <sup>3</sup>			Natural Frequency	
Gage Pressure (PSIG)	Load (lbs.)	Spring Rate (lbs./in.)	CPM	HZ
40	6,450	4,771	161	2.69
60	10,300	6,441	148	2.47
80	14,450	8,312	142	2.37
100	18,450	10,086	139	2.31

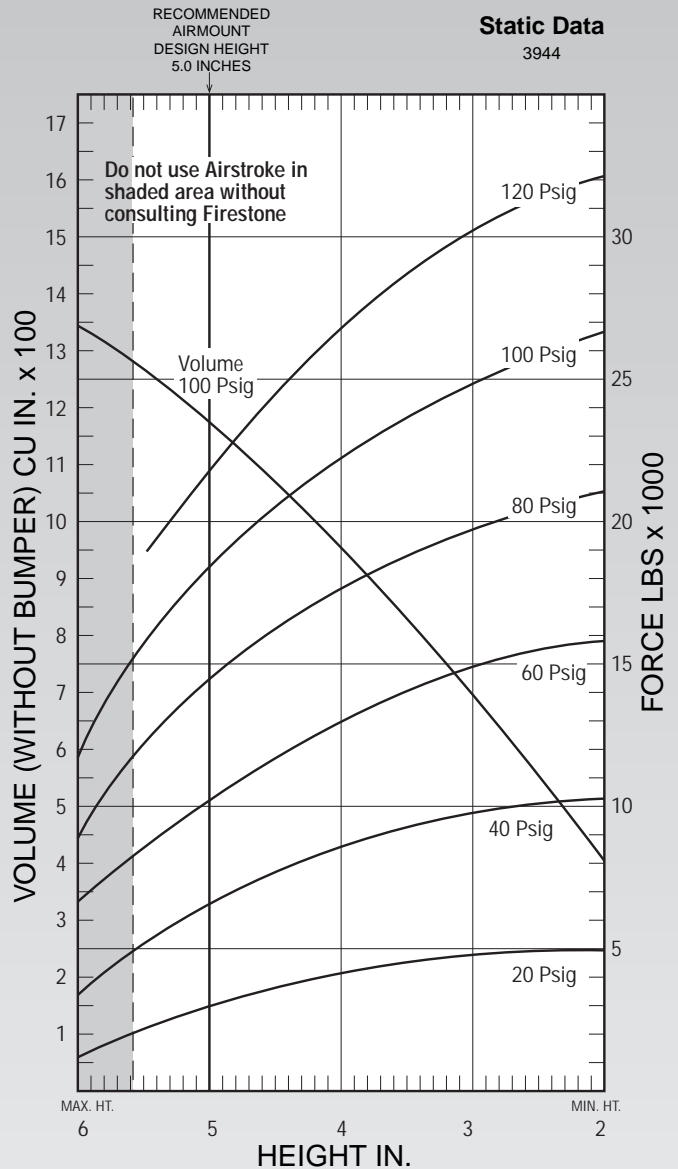

See page 12 for instructions on how to use chart.

Force Table (Use for Airstroke® actuator design)						
Assembly Height (in.)	Volume @ 100 PSIG (in <sup>3</sup> )	Pounds Force				
		@20 PSIG	@40 PSIG	@60 PSIG	@80 PSIG	@100 PSIG
5.0	1,154	2,830	6,450	10,300	14,450	18,450
4.0	935	4,100	8,540	13,070	17,550	22,180
3.0	682	4,760	9,690	14,750	19,600	24,690

Description		Assembly Order No.
Style 126	Ribbed neck aluminum bead rings (equal spacing), 1 7/8 bolts, nuts, washers	WO1-358-7727
Two Ply Bellows	Rolled Plate Assembly, 1/2 blind nuts, 3/4 NPT	WO1-358-7726
Assembly weight .....		21.3 lbs.
Force to collapse to minimum height (@ 0 PSIG).....		25 lbs.

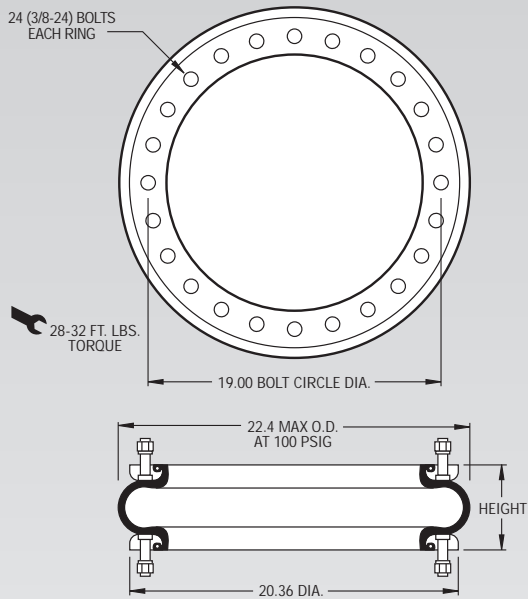

**NOTE: A bead ring part is shown. This part is also available with rolled plates. See page 11 for explanation.**

Dynamic Characteristics at 5.0 in. Design Height (Required for Airmount isolator design only)				
Volume @ 100 PSIG = 1,315 in <sup>3</sup>			Natural Frequency	
Gage Pressure (PSIG)	Load (lbs.)	Spring Rate (lbs./in.)	CPM	HZ
40	11,030	6,237	141	2.35
60	16,710	8,763	136	2.26
80	22,460	11,345	133	2.22
100	28,290	13,751	131	2.18

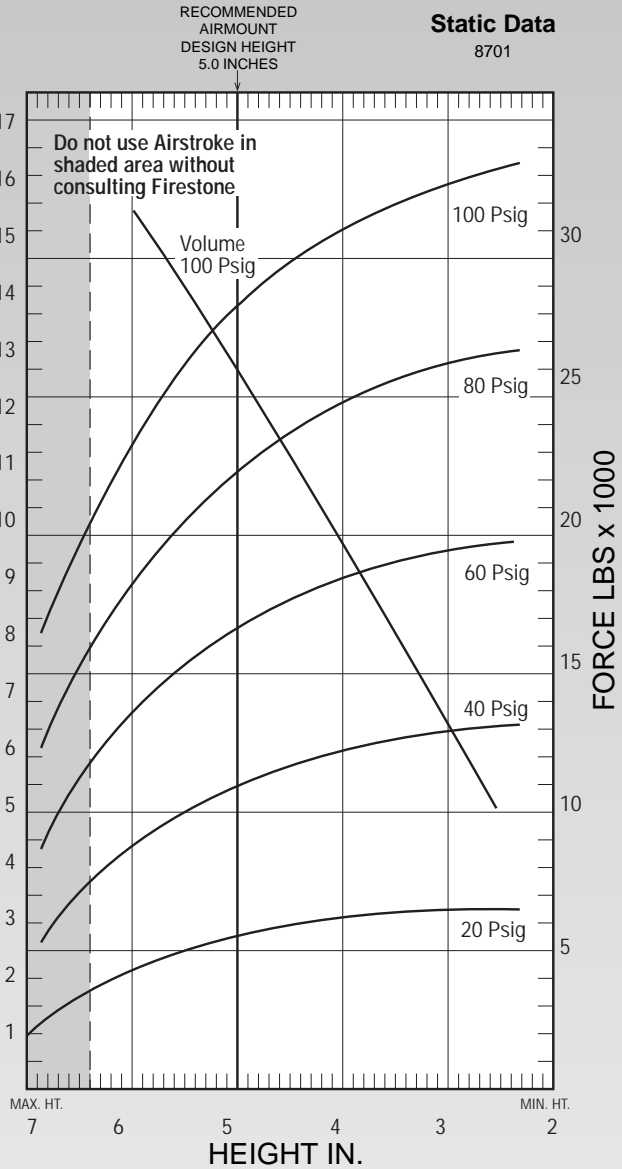

See page 12 for instructions on how to use chart.

Force Table (Use for Airstroke <sup>®</sup> actuator design)						
Assembly Height (in.)	Volume @ 100 PSIG (in <sup>3</sup> )	Pounds Force				
		@20 PSIG	@40 PSIG	@60 PSIG	@80 PSIG	@100 PSIG
6.0	1,589	4,390	8,880	13,580	18,360	23,450
5.0	1,315	5,560	11,030	16,710	22,460	28,290
4.0	1,007	6,120	12,120	18,330	24,660	30,930
3.0	676	6,440	12,830	19,330	25,990	32,600

Description		Assembly Order No.
Style 138-1.5	Ribbed neck aluminum bead rings (equal spacing), 17/8 bolts, nuts, washers	WO1-358-7737
Two Ply High Strength Bellows	Rubber bellows only	WO1-358-0147
Assembly weight .....		24.5 lbs.
Force to collapse to minimum height (@ 0 PSIG).....		150 lbs.

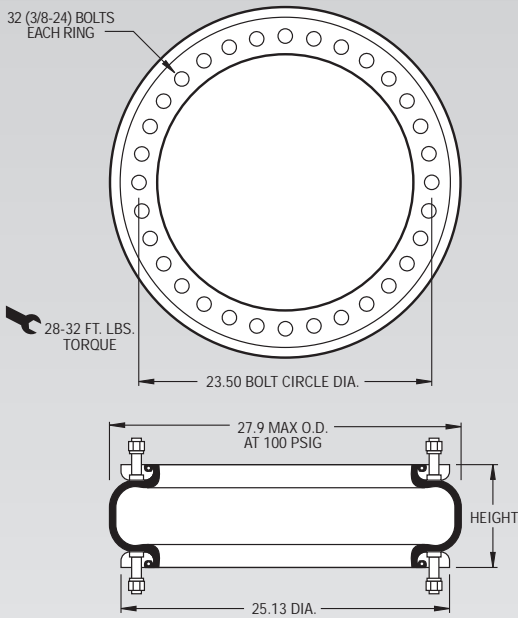

**NOTE: A bead ring part is shown. This part is also available with rolled plates. See page 11 for explanation.**

Dynamic Characteristics at 6.0 in. Design Height (Required for Airmount isolator design only)				
Volume @ 100 PSIG = 3,014 in <sup>3</sup>			Natural Frequency	
Gage Pressure (PSIG)	Load (lbs.)	Spring Rate (lbs./in.)	CPM	HZ
40	15,870	8,190	135	2.25
60	24,490	11,439	128	2.14
80	32,890	14,427	124	2.07
100	41,620	17,301	121	2.02

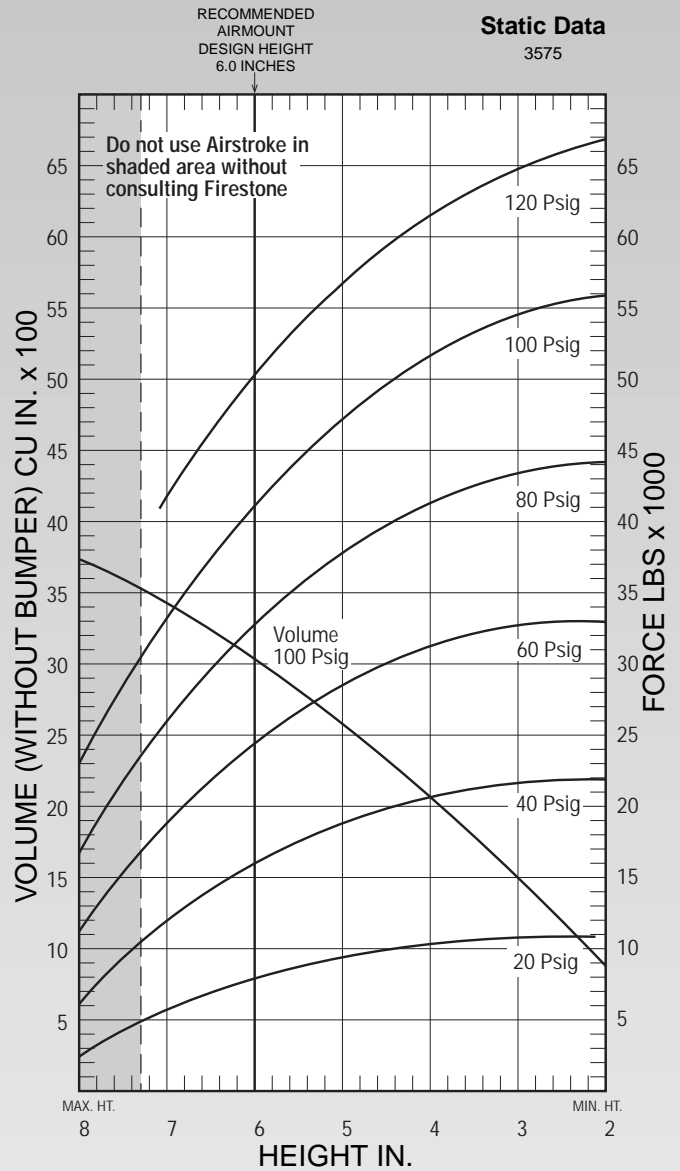

See page 12 for instructions on how to use chart.

Force Table (Use for Airstroke <sup>®</sup> actuator design)						
Assembly Height (in.)	Volume @ 100 PSIG (in <sup>3</sup> )	Pounds Force				
		@20 PSIG	@40 PSIG	@60 PSIG	@80 PSIG	@100 PSIG
9.0	3,419	5,390	11,420	18,340	25,320	32,820
8.0	3,014	7,770	15,870	24,490	32,890	41,620
7.0	2,552	9,410	18,910	28,740	38,230	47,890
6.0	2,045	10,360	20,670	31,280	41,520	51,850
5.0	1,509	10,860	21,560	32,660	43,430	54,250

# 148-1

# Firestone

# AIRSTROKE<sup>®</sup>

ACTUATORS

# AIRMOUNT<sup>®</sup>

ISOLATORS

Description		Assembly Order No.
Style 148-1	Ribbed neck aluminum bead rings (equal spacing), 1 7/8 bolts, nuts, washers	WO1-358-9601
High Strength Bellows		
Assembly weight .....		46.3 lbs.
Force to collapse to minimum height (@ 0 PSIG).....		310 lbs.

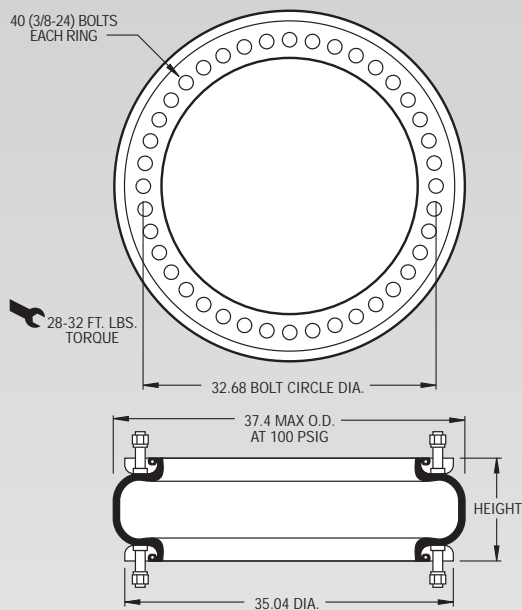

**NOTE:** The effective length of the 1 7/8 bolt is 1.02" in this bead ring.

Dynamic Characteristics at 5.5 in. Design Height (Required for Airmount isolator design only)				
Volume @ 100 PSIG = 4,914 in <sup>3</sup>			Natural Frequency	
Gage Pressure (PSIG)	Load (lbs.)	Spring Rate (lbs./in.)	CPM	HZ
40	32,860	14,220	123	2.06
60	50,290	19,969	118	1.97
80	67,690	26,697	118	1.96
100	85,200	32,491	116	1.93

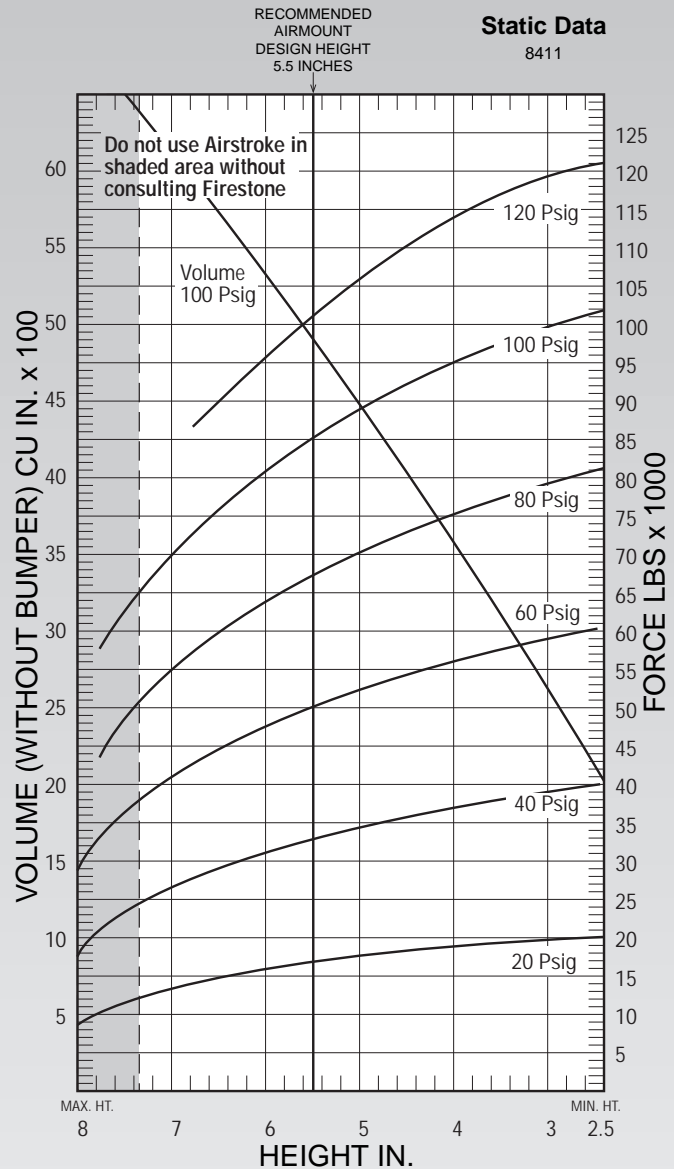

See page 12 for instructions on how to use chart.

Force Table (Use for Airstroke <sup>®</sup> actuator design)						
Assembly Height (in.)	Volume @ 100 PSIG (in <sup>3</sup> )	Pounds Force				
		@20 PSIG	@40 PSIG	@60 PSIG	@80 PSIG	@100 PSIG
7.0	6,134	13,470	26,890	41,610	55,830	70,860
6.0	5,337	15,720	31,220	47,920	64,170	80,890
5.0	4,471	17,450	34,310	52,370	70,980	89,140
4.0	3,532	18,810	36,970	56,050	76,330	95,540
3.0	2,542	19,940	39,470	59,360	80,110	100,050

Description		Assembly Order No.
Style 25	Blind nuts, 1/4 NPT	WO1-358-7025
	Blind nuts, 3/4 NPT	WO1-358-7047
Two Ply Bellows	Blind nuts, 1/4 NPT both ends	WO1-358-7035
	3/4 NPT both ends (no blind nuts)	WO1-606-7025
	Socket head aluminum bead rings (bolts, nuts, washers not included, use cap screws)	WO1-358-0030
	3/4 NPT (only) upper plate, blind nuts lower plate	WO1-358-7030
	Rubber bellows only (no girdle hoop)	WO1-358-0025
Assembly weight .....		3.8 lbs.
Force to collapse to minimum height (@ 0 PSIG).....		30 lbs.

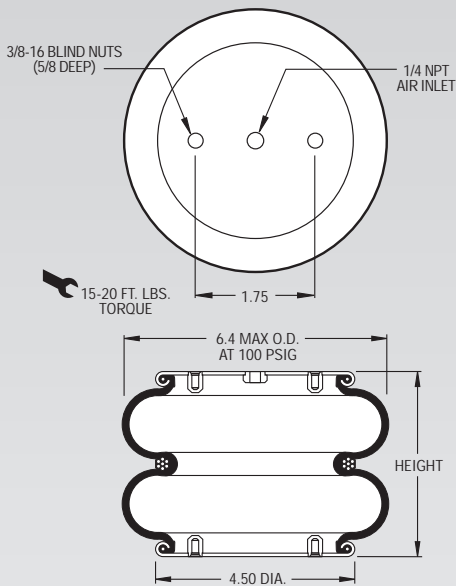

**NOTE: A bead plate part is shown. This part is also available with bead rings. Bolts are not included. See pages 8-10 for explanation.**

Dynamic Characteristics at 5.5 in. Design Height (Required for Airmount isolator design only)				
Volume @ 100 PSIG = 82 in <sup>3</sup>			Natural Frequency	
Gage Pressure (PSIG)	Load (lbs.)	Spring Rate (lbs./in.)	CPM	HZ
40	430	329	164	2.73
60	670	477	158	2.63
80	910	616	154	2.57
100	1,180	757	151	2.51

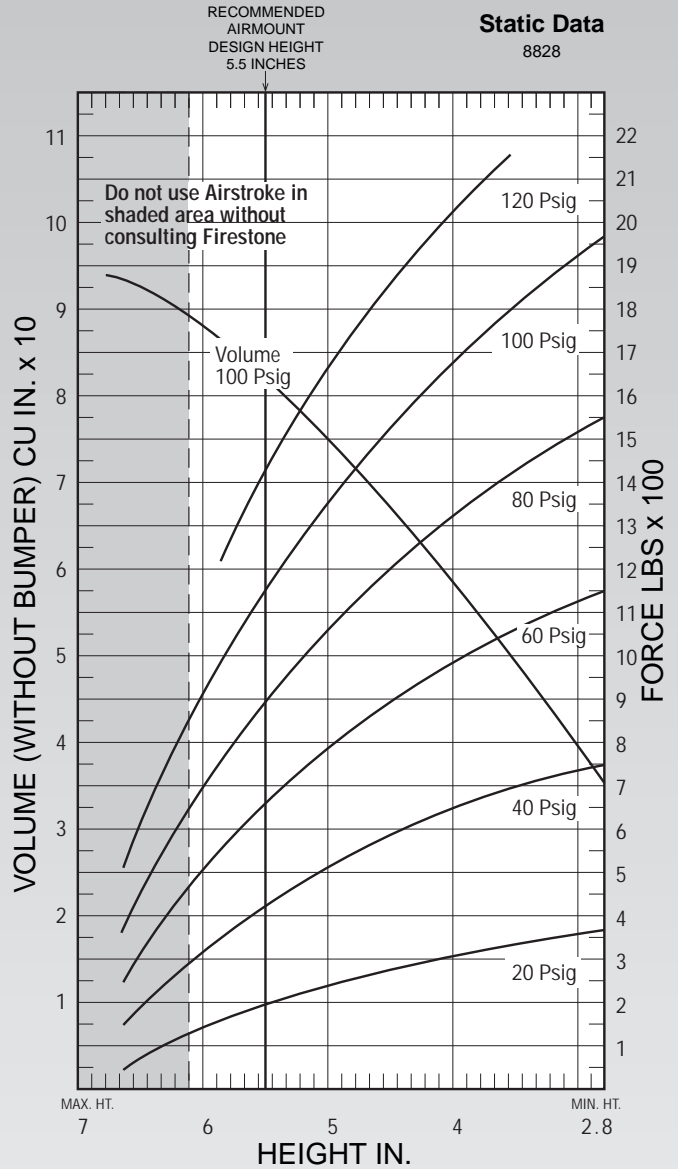

See page 12 for instructions on how to use chart.

Force Table (Use for Airstroke® actuator design)						
Assembly Height (in.)	Volume @ 100 PSIG (in <sup>3</sup> )	Pounds Force				
		@20 PSIG	@40 PSIG	@60 PSIG	@80 PSIG	@100 PSIG
5.0	75	240	520	800	1,080	1,380
4.0	58	310	660	990	1,330	1,690
3.0	39	360	750	1,130	1,530	1,930

# 255-1.5

# Firestone

# AIRSTROKE<sup>®</sup>

ACTUATORS

# AIRMOUNT<sup>®</sup>

ISOLATORS

Description		Assembly Order No.
Style 255-1.5	Blind nuts, 1/4 NPT	WO1-358-6955
	Blind nuts, 3/4 NPT	WO1-358-6956
Two Ply Bellows	Rubber bellows only	WO1-358-0048
Assembly weight .....		3.9 lbs.
Force to collapse to minimum height (@ 0 PSIG).....		50 lbs.

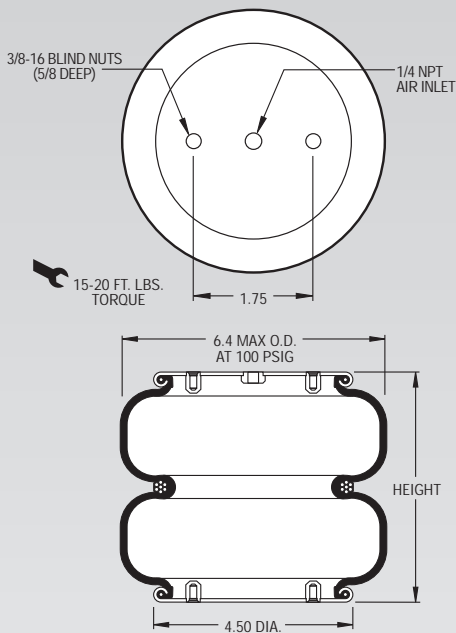

**NOTE: A bead plate part is shown. This part is also available with bead rings. Bolts are not included. See pages 8-10 for explanation.**

Dynamic Characteristics at 6.0 in. Design Height (Required for Airmount isolator design only)				
Volume @ 100 PSIG = 100 in <sup>3</sup>			Natural Frequency	
Gage Pressure (PSIG)	Load (lbs.)	Spring Rate (lbs./in.)	CPM	HZ
40	566	309	138.96	2.32
60	871	432	132.42	2.21
80	1,194	565	129.37	2.16
100	1,524	681	125.71	2.10

CONSULT FIRESTONE BEFORE USING AS AIRMOUNT

RECOMMENDED AIRMOUNT DESIGN HEIGHT 6.0 INCHES

**Static Data**  
B4652

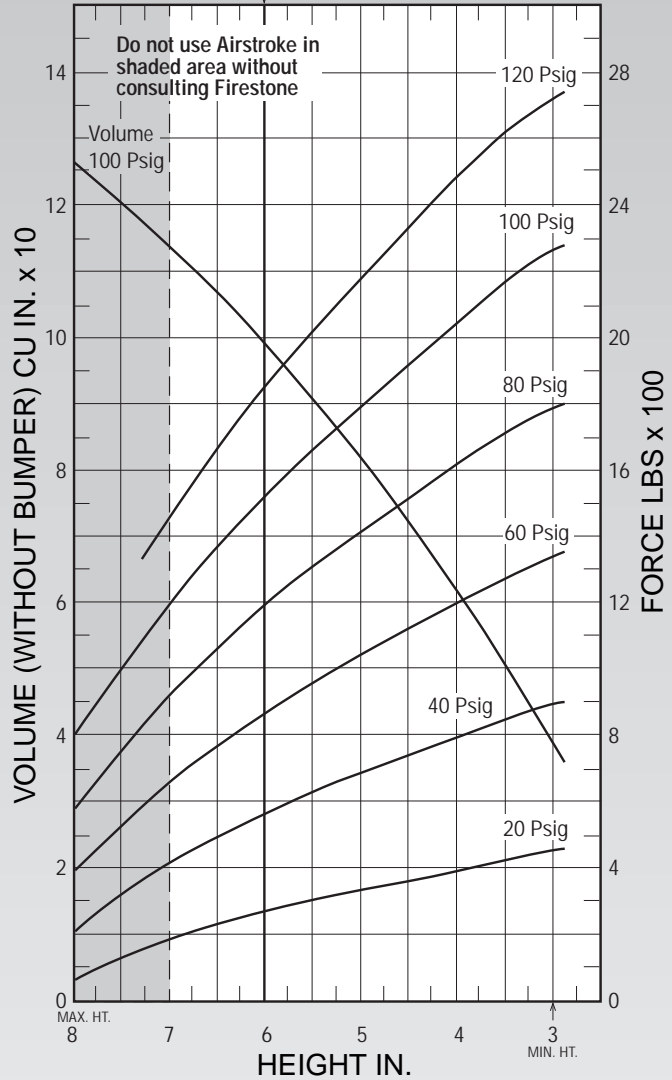

See page 12 for instructions on how to use chart.

Force Table (Use for Airstroke <sup>®</sup> actuator design)						
Assembly Height (in.)	Volume @ 100 PSIG (in <sup>3</sup> )	Pounds Force				
		@20 PSIG	@40 PSIG	@60 PSIG	@80 PSIG	@100 PSIG
7.0	114	188	417	661	921	1,198
6.0	100	270	566	871	1,194	1,524
5.0	82	331	686	1,041	1,414	1,786
4.0	62	389	729	1,197	1,612	2,039



Description		Assembly Order No.
Style 224	Blind nuts, 1/4 NPT	WO1-358-3400
	Blind nuts, 3/4 NPT	WO1-358-3403
Two Ply Bellows		
Assembly weight .....		5.0 lbs.
Force to collapse to minimum height (@ 0 PSIG).....		14 lbs.

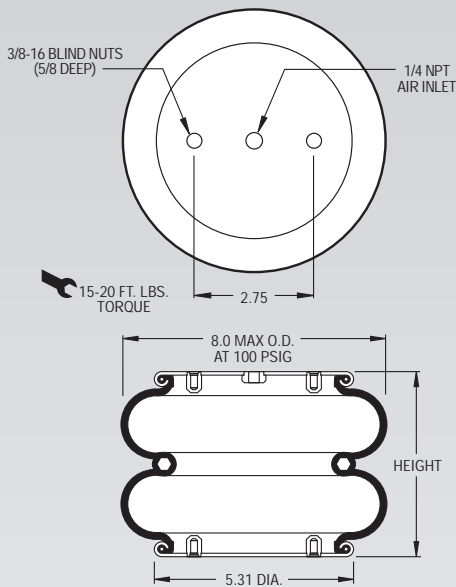

**NOTE:** A bead plate part is shown. This part is also available with bead rings. See pages 8-10 for explanation.

Dynamic Characteristics at 6.5 in. Design Height (Required for Airmount isolator design only)				
Volume @ 100 PSIG = 171 in <sup>3</sup>			Natural Frequency	
Gage Pressure (PSIG)	Load (lbs.)	Spring Rate (lbs./in.)	CPM	HZ
40	730	361	132	2.20
60	1,130	523	128	2.13
80	1,530	690	126	2.10
100	1,940	849	124	2.07

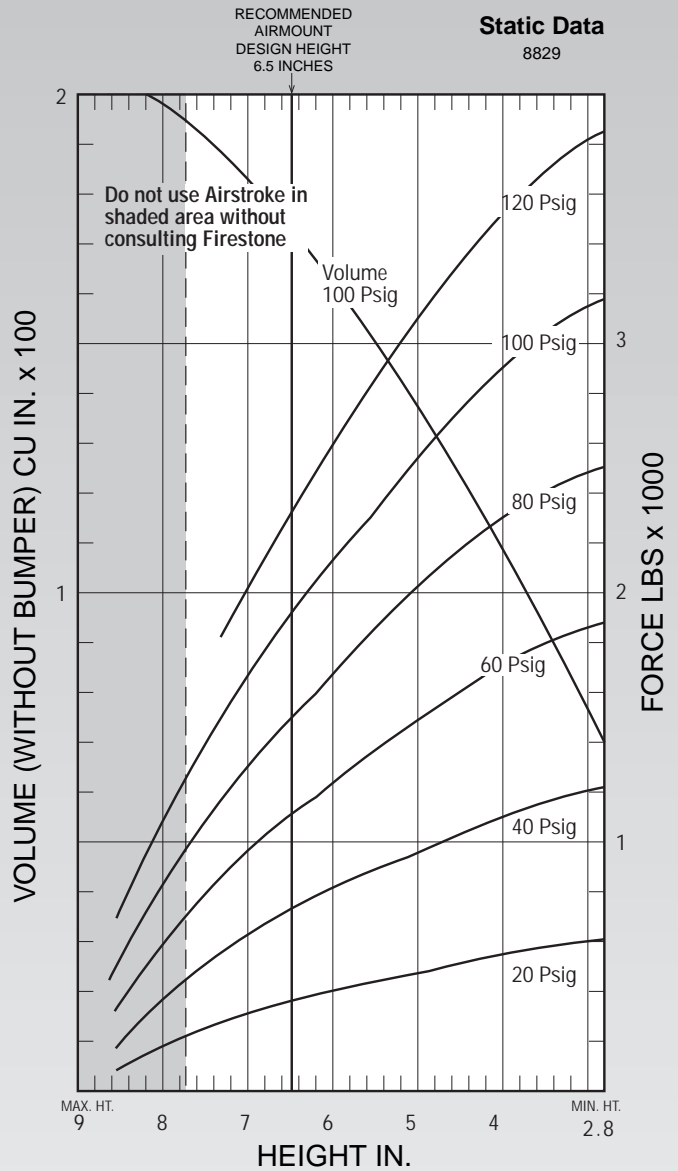

See page 12 for instructions on how to use chart.

Force Table (Use for Airstroke <sup>®</sup> actuator design)						
Assembly Height (in.)	Volume @ 100 PSIG (in <sup>3</sup> )	Pounds Force				
		@20 PSIG	@40 PSIG	@60 PSIG	@80 PSIG	@100 PSIG
7.0	181	320	630	990	1,340	1,710
6.0	160	400	820	1,260	1,700	2,160
5.0	134	470	960	1,490	2,040	2,570
4.0	105	550	1,110	1,720	2,310	2,930
3.0	73	590	1,210	1,860	2,480	3,150

Description		Assembly Order No.
Style 26	Blind nuts, 1/4 NPT	WO1-358-7325
	Blind nuts, 3/4 NPT	WO1-358-7327
Two Ply Bellows	Button head steel bead rings, 1 7/8 bolts, nuts, washers	WO1-358-7333
	Rubber bellows only	WO1-358-0142
Assembly weight .....		5.3 lbs.
Force to collapse to minimum height (@ 0 PSIG).....		23 lbs.

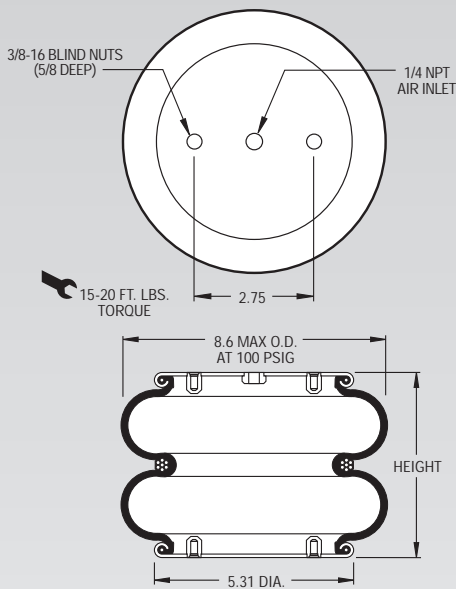

**NOTE: A bead plate part is shown. This part is also available with bead rings. See pages 8-10 for explanation.**

Dynamic Characteristics at 8.0 in. Design Height (Required for Airmount isolator design only)				
Volume @ 100 PSIG = 241 in <sup>3</sup>			Natural Frequency	
Gage Pressure (PSIG)	Load (lbs.)	Spring Rate (lbs./in.)	CPM	HZ
40	790	322	120	1.99
60	1,230	454	114	1.90
80	1,670	589	111	1.85
100	2,140	720	109	1.82

RECOMMENDED  
AIRMOUNT  
DESIGN HEIGHT  
8.0 INCHES

**Static Data**  
8442

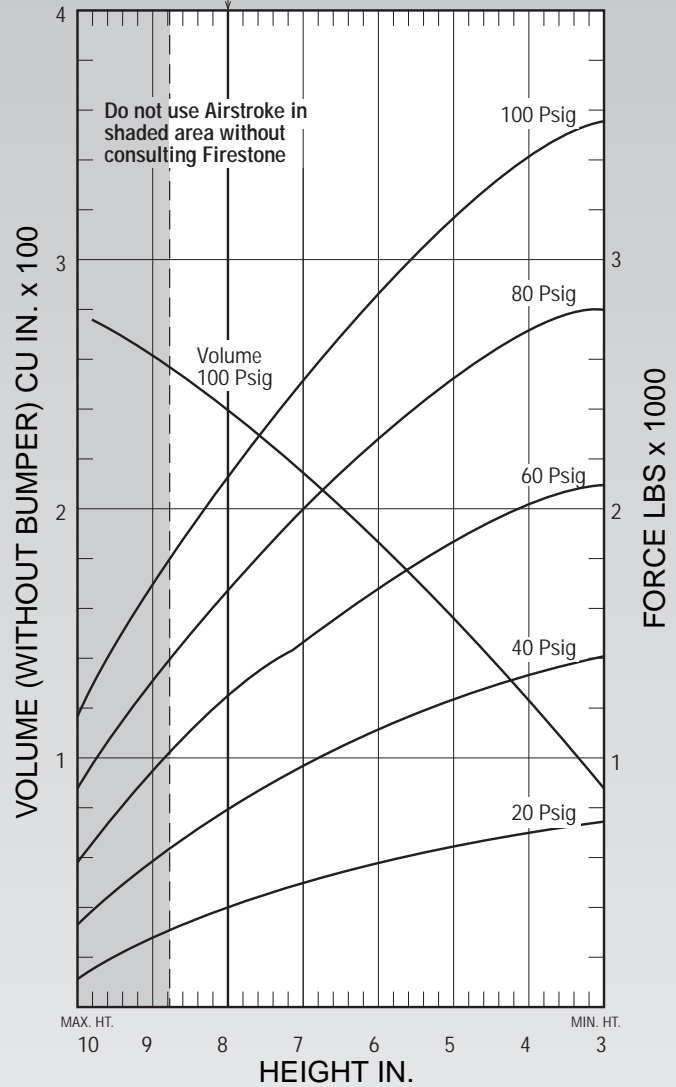

See page 12 for instructions on how to use chart.

Force Table (Use for Airstroke <sup>®</sup> actuator design)						
Assembly Height (in.)	Volume @ 100 PSIG (in <sup>3</sup> )	Pounds Force				
		@20 PSIG	@40 PSIG	@60 PSIG	@80 PSIG	@100 PSIG
8.0	241	400	790	1,230	1,670	2,140
7.0	217	490	950	1,460	1,970	2,500
6.0	189	570	1,090	1,660	2,230	2,820
5.0	158	640	1,220	1,850	2,490	3,140
4.0	124	690	1,340	2,010	2,700	3,400

Description		Assembly Order No.
Style 20	Blind nuts, 1/4 NPT	WO1-358-6910
	Blind nuts, 1/4 NPT, bumper	WO1-358-6911
Two Ply Bellows	Blind nuts, 3/4 NPT	WO1-358-6900
	Blind nuts, 3/4 NPT, bumper	WO1-358-6901
	Countersunk steel bead rings, 1 3/4 bolts, nuts, washers	WO1-358-6923
	Rubber bellows only	WO1-358-7901

Assembly weight ..... 7.5 lbs.  
Force to collapse to minimum height (@ 0 PSIG)..... 14 lbs.

Style 202	Blind nuts, 1/4 NPT	WO1-358-7080
High Strength Bellows	Blind nuts, 3/4 NPT	WO1-358-7119

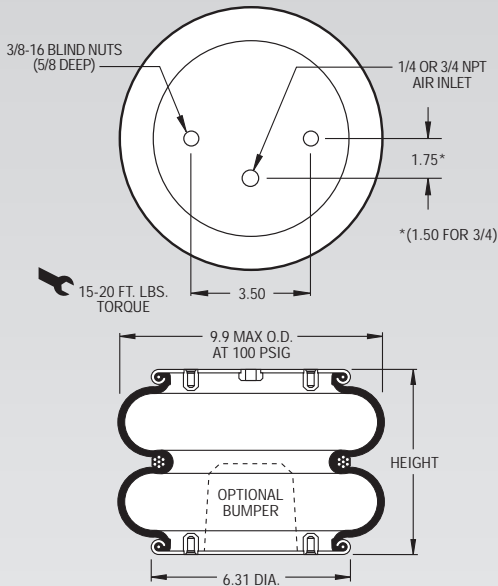

**NOTE: A bead plate part is shown. This part is also available with bead rings. See pages 8-10 for explanation.**

Dynamic Characteristics at 8.5 in. Design Height (Required for Airmount isolator design only)				
Volume @ 100 PSIG = 376 in <sup>3</sup>			Natural Frequency	
Gage Pressure (PSIG)	Load (lbs.)	Spring Rate (lbs./in.)	CPM	HZ
40	990	414	121	2.02
60	1,540	615	119	1.98
80	2,130	820	116	1.94
100	2,720	996	114	1.89

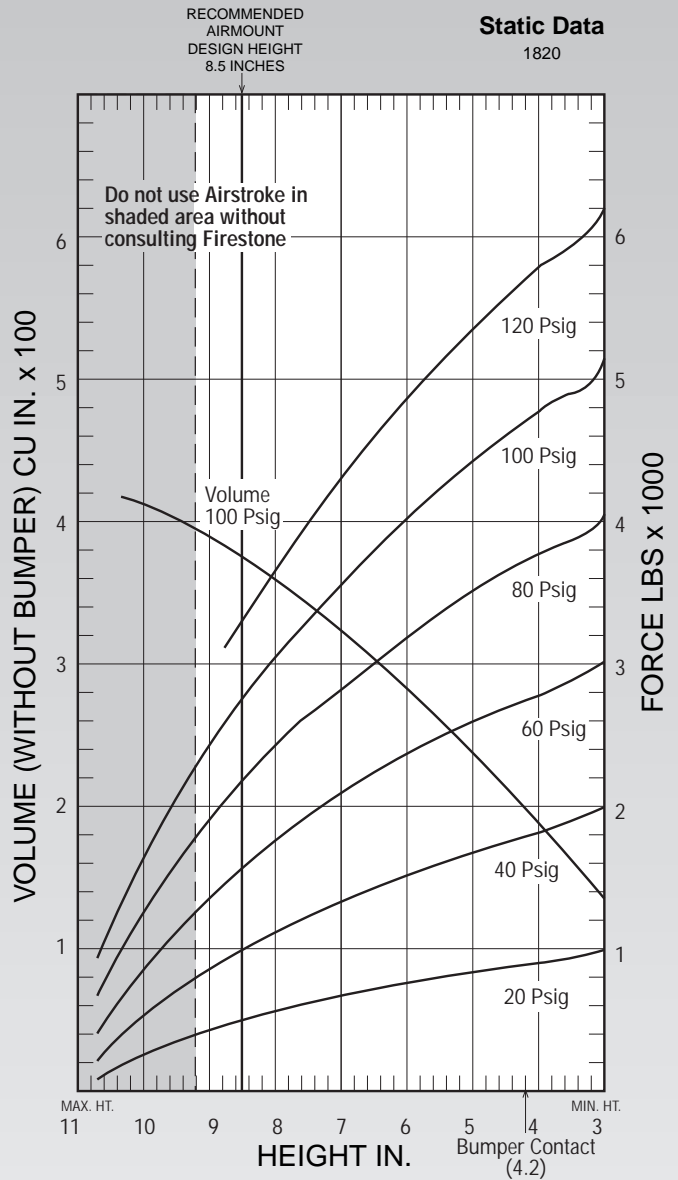

See page 12 for instructions on how to use chart.

Force Table (Use for Airstroke® actuator design)						
Assembly Height (in.)	Volume @ 100 PSIG (in <sup>3</sup> )	Pounds Force				
		@20 PSIG	@40 PSIG	@60 PSIG	@80 PSIG	@100 PSIG
9.0	390	420	850	1,330	1,850	2,380
8.0	360	550	1,120	1,730	2,390	3,030
7.0	325	660	1,330	2,090	2,830	3,570
6.0	284	760	1,520	2,390	3,180	4,030
5.0	239	840	1,680	2,610	3,510	4,430
4.0	190	920	1,830	2,810	3,790	4,790

Description		Assembly Order No.
Style 20-2	Blind nuts, 1/4 NPT	WO1-358-6951
	Blind nuts, 3/4 NPT	WO1-358-6952
Two Ply Bellows	Blind nuts, 3/4 NPT, rubber bumper	WO1-358-6947
	Rubber bellows only	WO1-358-0152
Assembly weight .....		7.7 lbs.
Force to collapse to minimum height (@ 0 PSIG).....		17 lbs.

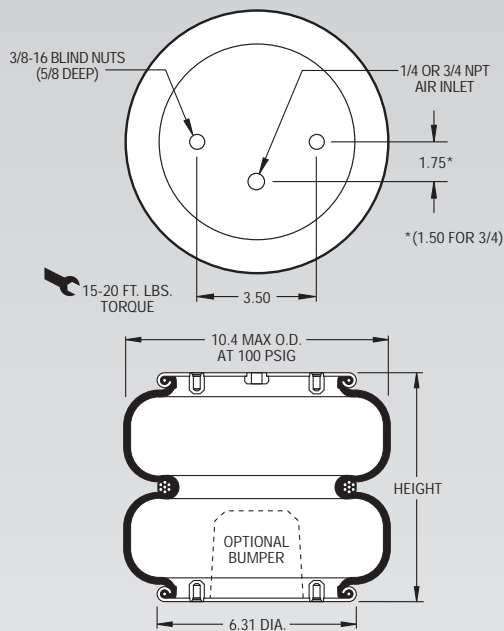

**NOTE: A bead plate part is shown. This part is also available with bead rings. See pages 8-10 for explanation.**

Dynamic Characteristics at 10.0 in. Design Height				
Consult factory before using as an Airmount isolator.				
Volume @ 100 PSIG = 488 in <sup>3</sup>			Natural Frequency	
Gage Pressure (PSIG)	Load (lbs.)	Spring Rate (lbs./in.)	CPM	HZ
40	1,184	376	105.91	1.77
60	1,848	534	101.04	1.68
80	2,531	669	96.64	1.61
100	3,238	813	94.21	1.57

CONSULT FIRESTONE BEFORE USING AS AIRMOUNT

RECOMMENDED AIRMOUNT DESIGN HEIGHT 10.0 INCHES

### Static Data

A9902

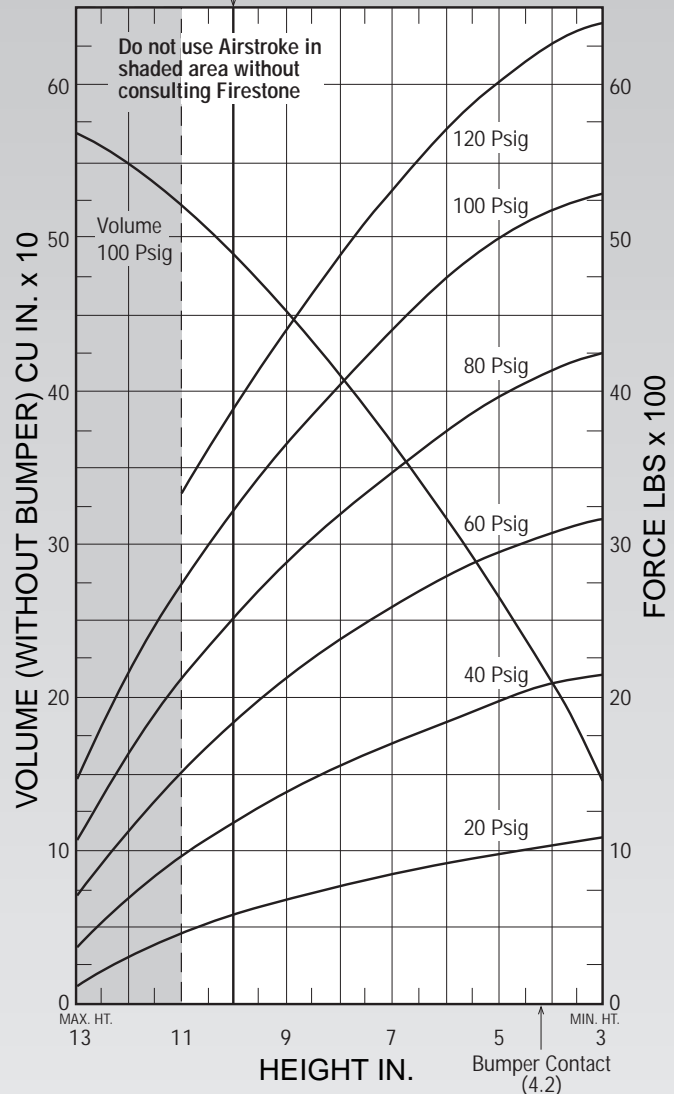

See page 12 for instructions on how to use chart.

Force Table (Use for Airstroke <sup>®</sup> actuator design)						
Assembly Height (in.)	Volume @ 100 PSIG (in <sup>3</sup> )	Pounds Force				
		@20 PSIG	@40 PSIG	@60 PSIG	@80 PSIG	@100 PSIG
11.0	520	449	951	1,517	2,122	2,753
10.0	488	572	1,184	1,848	2,531	3,238
9.0	451	673	1,384	2,134	2,880	3,661
8.0	409	759	1,554	2,377	3,193	4,049
7.0	364	836	1,704	2,590	3,485	4,416
6.0	316	907	1,845	2,786	3,753	4,748
5.0	256	975	1,979	2,954	3,968	5,005

Description		Assembly Order No.
Style 22	Blind nuts, 1/4 NPT	WO1-358-7180
	Blind nuts, 1/4 NPT, bumper	WO1-358-7400
Two Ply Bellows	Blind nuts, 3/4 NPT	WO1-358-7184
	Blind nuts, 3/4 NPT, bumper	WO1-358-7185
	Countersunk steel bead rings, 1 5/8 bolts, nuts, washers	WO1-358-7431
	Rubber bellows only	WO1-358-0226

Assembly weight ..... 12.3 lbs  
 Force to collapse to minimum height (@ 0 PSIG)..... 20 lbs.

Style 210	Blind nuts, 1/4 NPT	WO1-358-7251
	Blind nuts, 1/4 NPT, bumper	WO1-358-7291
High Strength Bellows	Blind nuts, 3/4 NPT	WO1-358-7250
	Countersunk steel bead rings, 1 3/4 bolts, nuts, washers	WO1-358-7258
	Rubber bellows only	WO1-358-7928

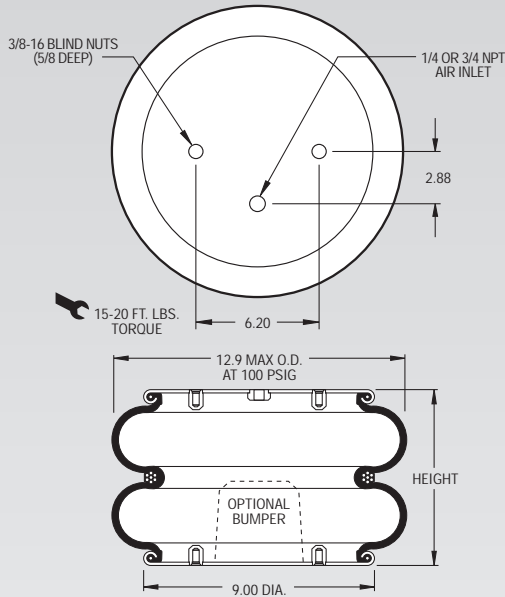

**NOTE: A bead plate part is shown. This part is also available with bead rings. See pages 8-10 for explanation.**

Dynamic Characteristics at 9.5 in. Design Height (Required for Airmount isolator design only)				
Volume @ 100 PSIG = 782 in <sup>3</sup>			Natural Frequency	
Gage Pressure (PSIG)	Load (lbs.)	Spring Rate (lbs./in.)	CPM	HZ
40	2,050	729	112	1.86
60	3,170	1,036	107	1.79
80	4,280	1,373	106	1.77
100	5,400	1,668	104	1.74

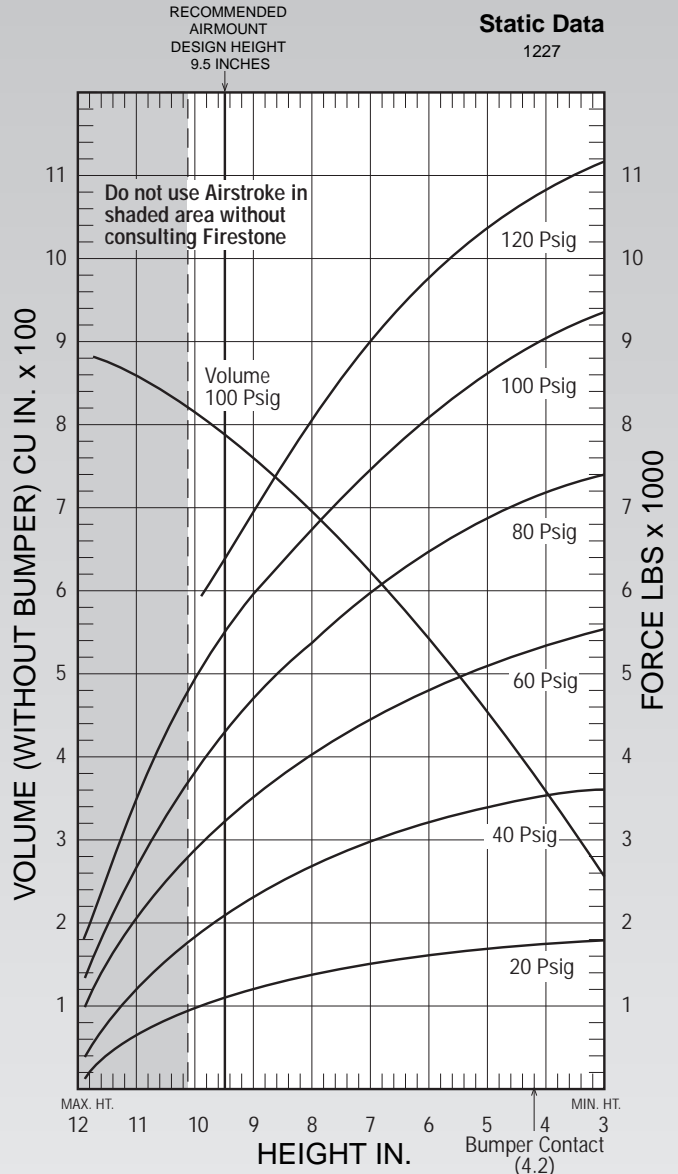

See page 12 for instructions on how to use chart.

Assembly Height (in.)	Volume @ 100 PSIG (in <sup>3</sup> )	Pounds Force				
		@20 PSIG	@40 PSIG	@60 PSIG	@80 PSIG	@100 PSIG
10.0	809	950	1,810	2,830	3,810	4,840
9.0	752	1,170	2,260	3,460	4,670	5,880
8.0	685	1,310	2,590	3,940	5,350	6,700
7.0	610	1,430	2,900	4,390	5,950	7,450
6.0	529	1,540	3,170	4,780	6,470	8,110
5.0	442	1,640	3,380	5,100	6,880	8,630
4.0	349	1,730	3,520	5,340	7,180	9,020

# 22-1.5

# Firestone

# AIRSTROKE<sup>®</sup>

ACTUATORS

# AIRMOUNT<sup>®</sup>

ISOLATORS

Description		Assembly Order No.
Style 22-1.5 Two Ply Bellows	Blind nuts, 1/4 NPT	WO1-358-7444
	Blind nuts, 1/4 NPT, rubber bumper	WO1-358-7473
	Blind nuts, 3/4 NPT	WO1-358-7442
	Blind nuts, 1/4 NPT(centered)	WO1-358-7443
	Rubber bellows only	WO1-358-0259
Assembly weight .....		12.9 lbs.
Force to collapse to minimum height (@ 0 PSIG).....		26 lbs.

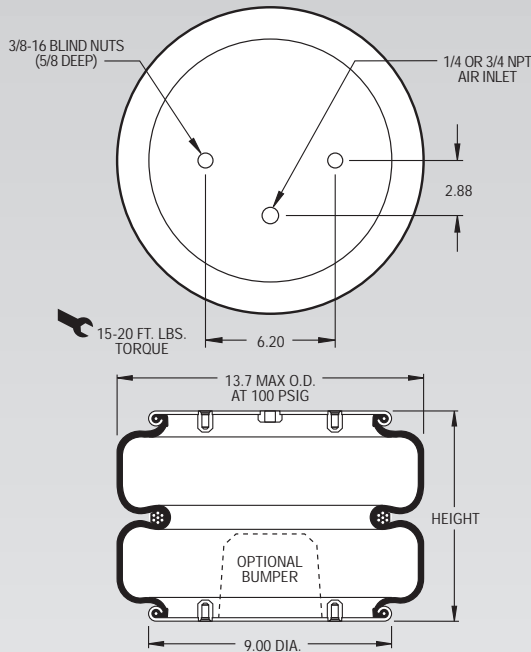

**NOTE:** The bellows extends beyond the bead plates at minimum height.

**NOTE:** A bead plate part is shown. This part is also available with bead rings. See pages 8-10 for explanation.

Dynamic Characteristics at 10.5 in. Design Height (Required for Airmount isolator design only)				
Volume @ 100 PSIG = 935 in <sup>3</sup>			Natural Frequency	
Gage Pressure (PSIG)	Load (lbs.)	Spring Rate (lbs./in.)	CPM	HZ
40	1,930	684	112	1.86
60	3,030	999	108	1.80
80	4,130	1,319	106	1.77
100	5,310	1,630	104	1.73

RECOMMENDED  
AIRMOUNT  
DESIGN HEIGHT  
10.5 INCHES

**Static Data**  
1889

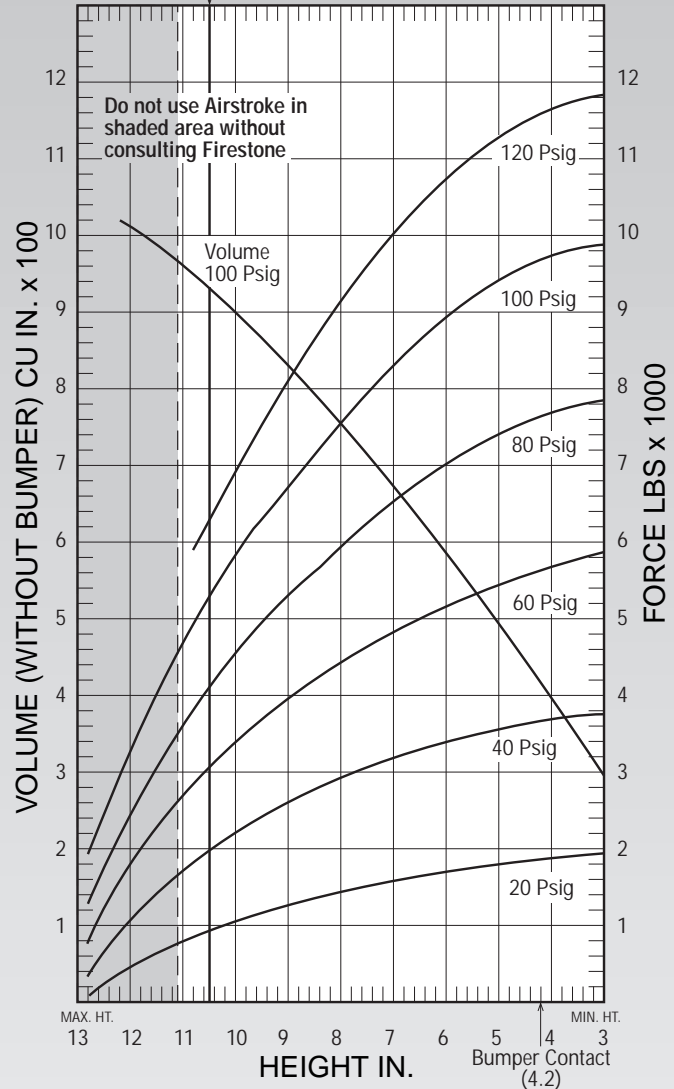

See page 12 for instructions on how to use chart.

Force Table (Use for Airstroke <sup>®</sup> actuator design)						
Assembly Height (in.)	Volume @ 100 PSIG (in <sup>3</sup> )	Pounds Force				
		@20 PSIG	@40 PSIG	@60 PSIG	@80 PSIG	@100 PSIG
10.0	905	1,040	2,140	3,340	4,550	5,830
9.0	838	1,220	2,520	3,880	5,250	6,700
8.0	763	1,370	2,850	4,360	5,850	7,450
7.0	681	1,510	3,150	4,810	6,430	8,170
6.0	591	1,650	3,400	5,210	6,990	8,860
5.0	496	1,760	3,590	5,520	7,420	9,380
4.0	396	1,840	3,730	5,730	7,680	9,700

Description		Assembly Order No.
Style 21	Blind nuts, 1/4 NPT	WO1-358-7145
	Blind nuts, 1/4 NPT, bumper	WO1-358-7146
Two Ply Bellows	Blind nuts, 3/4 NPT	WO1-358-7143
	Blind nuts, 3/4 NPT, bumper	WO1-358-7144
	Button head steel bead rings, 1 7/8 bolts, nuts, washers	WO1-358-7139
	Rubber bellows only	WO1-358-0213
Assembly weight .....		17.3 lbs
Force to collapse to minimum height (@ 0 PSIG).....		22 lbs.

Style 205	Blind nuts, 1/4 NPT	WO1-358-7208
	Blind nuts, 1/4 NPT, bumper	WO1-358-7221
High Strength Bellows	Blind nuts, 3/4 NPT	WO1-358-7224
	Button head steel bead rings, 1 7/8 bolts, nuts, washers	WO1-358-7237
	Rubber bellows only	WO1-358-7929

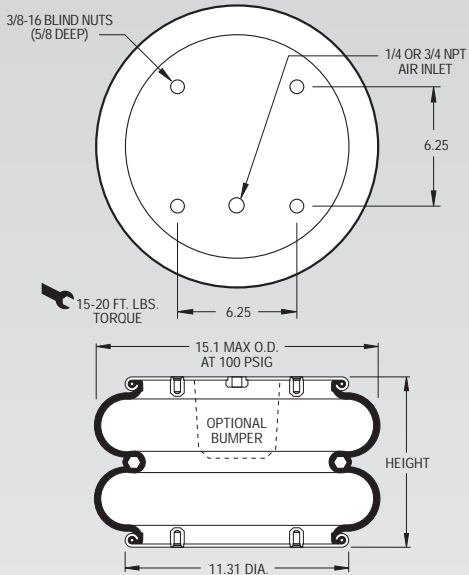

**NOTE: A bead plate part is shown. This part is also available with bead rings. See pages 8-10 for explanation.**

Dynamic Characteristics at 9.5 in. Design Height (Required for Airmount isolator design only)				
Volume @ 100 PSIG = 1,136 in <sup>3</sup>			Natural Frequency	
Gage Pressure (PSIG)	Load (lbs.)	Spring Rate (lbs./in.)	CPM	HZ
40	3,030	1,110	114	1.89
60	4,750	1,582	108	1.80
80	6,540	2,044	105	1.75
100	8,330	2,500	103	1.71

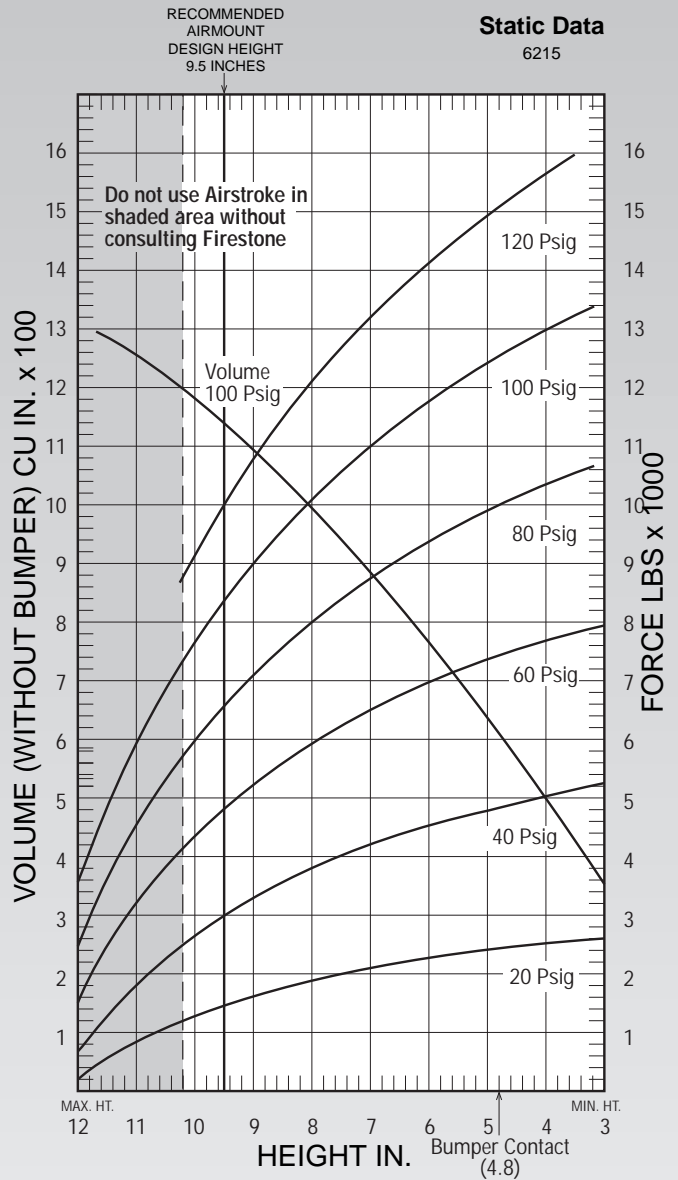

See page 12 for instructions on how to use chart.

Force Table (Use for Airstroke® actuator design)						
Assembly Height (in.)	Volume @ 100 PSIG (in <sup>3</sup> )	Pounds Force				
		@20 PSIG	@40 PSIG	@60 PSIG	@80 PSIG	@100 PSIG
10.0	1,180	1,260	2,670	4,240	5,890	7,550
9.0	1,091	1,590	3,330	5,180	7,100	9,010
8.0	989	1,810	3,800	5,850	7,980	10,120
7.0	878	2,000	4,180	6,400	8,700	11,020
6.0	758	2,160	4,490	6,860	9,310	11,760
5.0	630	2,300	4,760	7,260	9,830	12,400
4.0	497	2,440	5,010	7,620	10,300	12,960

Description		Assembly Order No.
Style 21-2	Blind nuts, 1/4 NPT	WO1-358-6800
Two Ply Bellows	Blind nuts, 1/4 NPT, rubber bumper	WO1-358-6801
	Blind nuts, 3/4 NPT	WO1-358-9529
Assembly weight .....		18.2 lbs
Force to collapse to minimum height (@ 0 PSIG).....		35 lbs.

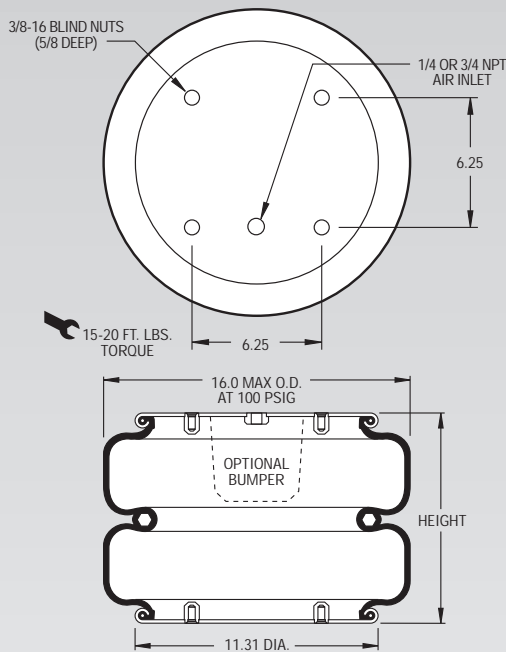

**NOTE:** The bellows extends beyond the bead plates at minimum height.

**NOTE:** A bead plate part is shown. This part is also available with bead rings. See pages 8-10 for explanation.

Dynamic Characteristics at 10.5 in. Design Height (Required for Airmount isolator design only)				
Volume @ 100 PSIG = 1,462 in <sup>3</sup>			Natural Frequency	
Gage Pressure (PSIG)	Load (lbs.)	Spring Rate (lbs./in.)	CPM	HZ
40	3,460	989	100	1.67
60	5,350	1,437	97	1.62
80	7,280	1,850	95	1.58
100	9,210	2,247	93	1.55

RECOMMENDED  
AIRMOUNT  
DESIGN HEIGHT  
10.5 INCHES

**Static Data**  
3931

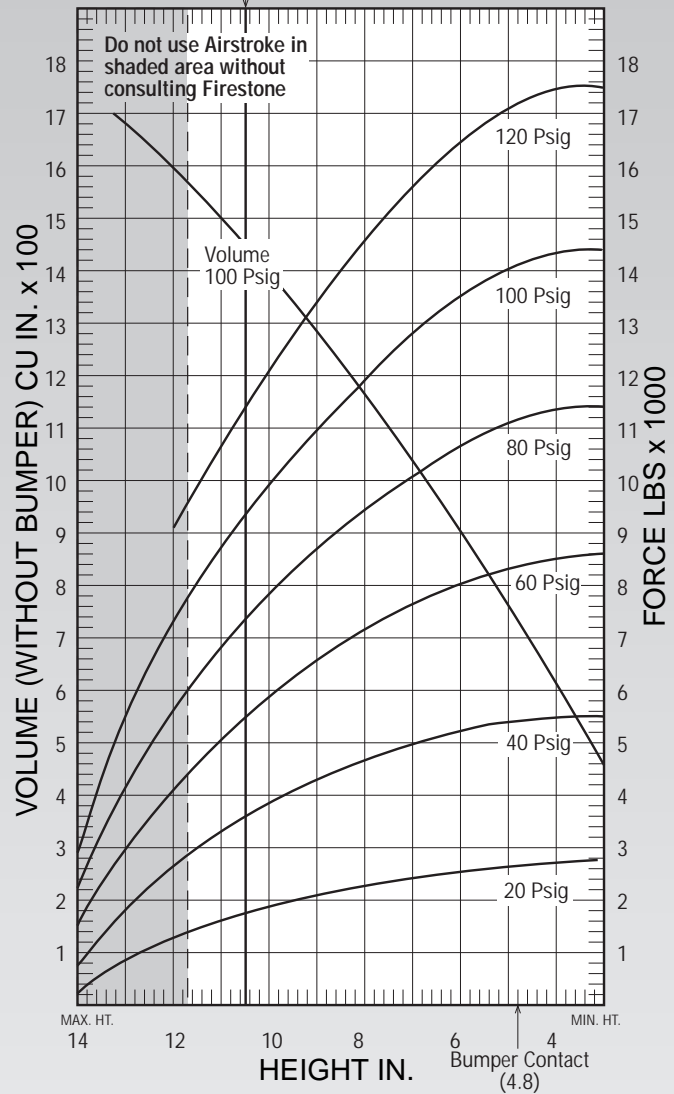

See page 12 for instructions on how to use chart.

Force Table (Use for Airstroke <sup>®</sup> actuator design)						
Assembly Height (in.)	Volume @ 100 PSIG (in <sup>3</sup> )	Pounds Force				
		@20 PSIG	@40 PSIG	@60 PSIG	@80 PSIG	@100 PSIG
11.0	1,510	1,540	3,180	4,930	6,730	8,550
10.0	1,410	1,810	3,710	5,730	7,760	9,790
9.0	1,298	2,040	4,150	6,430	8,570	10,780
8.0	1,177	2,240	4,530	7,050	9,290	11,690
7.0	1,048	2,400	4,850	7,570	10,030	12,620
6.0	910	2,530	5,140	8,000	10,670	13,440
5.0	764	2,620	5,370	8,310	11,100	13,990
4.0	615	2,690	5,490	8,490	11,330	14,280



Description		Assembly Order No.
Style 233-2	Blind nuts, 1/4 NPT	WO1-358-6810
Two	Blind nuts, 1/4 NPT, rubber bumper	WO1-358-7781
Ply Bellows	Blind nuts, 3/4 NPT	WO1-358-6811
Assembly weight .....		19.6 lbs
Force to collapse to minimum height (@ 0 PSIG).....		100 lbs.

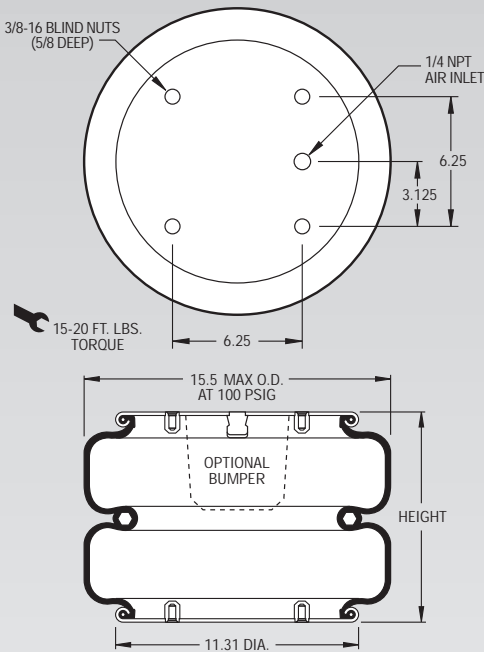

**NOTE:** The bellows extends beyond the bead plates at minimum height.

**NOTE:** A bead plate part is shown. This part is also available with bead rings. See pages 8-10 for explanation.

Dynamic Characteristics at 11.25 in. Design Height (Required for Airmount isolator design only)				
Volume @ 100 PSIG = 1,418 in <sup>3</sup>			Natural Frequency	
Gage Pressure (PSIG)	Load (lbs.)	Spring Rate (lbs./in.)	CPM	HZ
40	3,413	968	100	1.67
60	5,631	1,351	92	1.53
80	7,691	1,735	89	1.49
100	9,917	2,122	87	1.45

CONSULT FIRESTONE BEFORE USING AS AIRMOUNT  
RECOMMENDED AIRMOUNT DESIGN HEIGHT 11.25 INCHES  
**Static Data**  
A9899

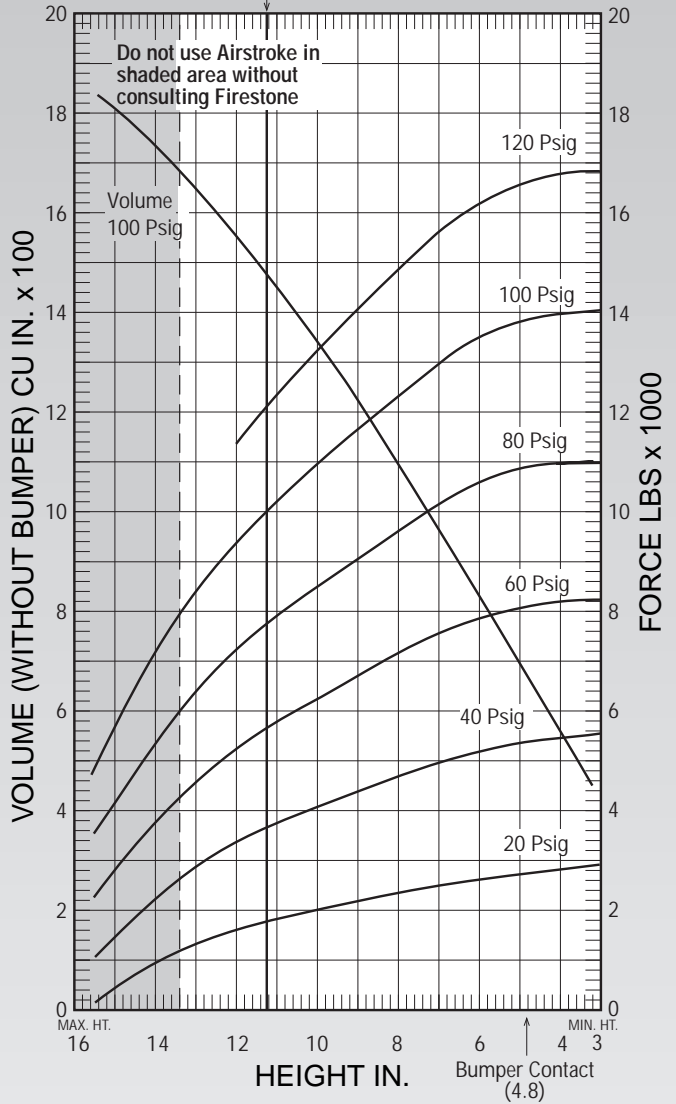

See page 12 for instructions on how to use chart.

Force Table (Use for Airstroke® actuator design)						
Assembly Height (in.)	Volume @ 100 PSIG (in <sup>3</sup> )	Pounds Force				
		@20 PSIG	@40 PSIG	@60 PSIG	@80 PSIG	@100 PSIG
12.0	1,548	1,542	3,299	5,184	7,194	9,321
10.0	1,333	1,992	4,052	6,239	8,483	10,937
8.0	1,091	2,311	4,666	7,128	9,601	12,333
6.0	829	2,569	5,174	7,485	10,564	13,468
4.0	556	2,793	5,431	8,189	10,966	13,867

Description		Assembly Order No.
Style 28	Ribbed neck aluminum bead rings (equal spacing), 1 7/8 bolts, nuts, washers	WO1-358-7191
Two Ply Bellows	Ribbed neck aluminum bead rings (unequal spacing) 1 7/8 b,n,w	WO1-358-7194
	Ribbed neck aluminum bead rings (equal spacing) 1 1/4 b,n,w	WO1-358-7192
	Rolled plate assembly, 1/2 blind but 3/4 NPT	WO1-358-7271
	Rubber bellows only	WO1-358-7925
	Assembly weight .....	19.0 lbs
Force to collapse to minimum height (@ 0 PSIG).....		38 lbs.

Style 201 High Strength Bellows	Ribbed neck aluminum bead rings (equal spacing)	WO1-358-7244
	Rubber Bellows Only	WO1-139-0201

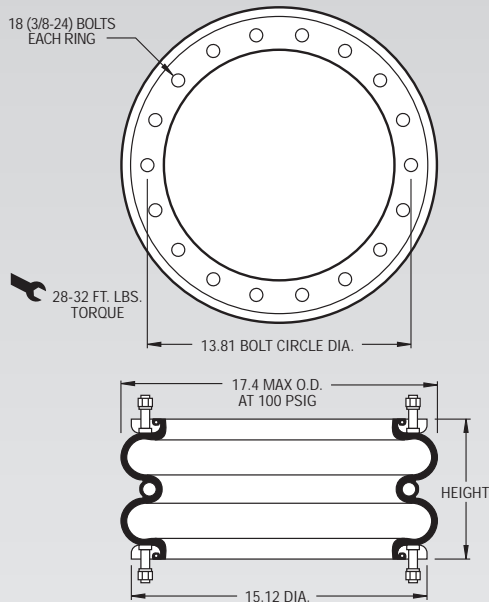

**NOTE: A bead ring part is shown. This part is also available with rolled plates. See page 11 for explanation.**

Dynamic Characteristics at 9.5 in. Design Height (Required for Airmount isolator design only)				
Volume @ 100 PSIG = 1,596 in <sup>3</sup>			Natural Frequency	
Gage Pressure (PSIG)	Load (lbs.)	Spring Rate (lbs./in.)	CPM	HZ
40	4,590	1,553	109	1.82
60	7,010	2,125	103	1.72
80	9,590	2,779	101	1.68
100	12,120	3,471	100	1.67

RECOMMENDED AIRMOUNT DESIGN HEIGHT 9.5 INCHES

**Static Data**  
5526

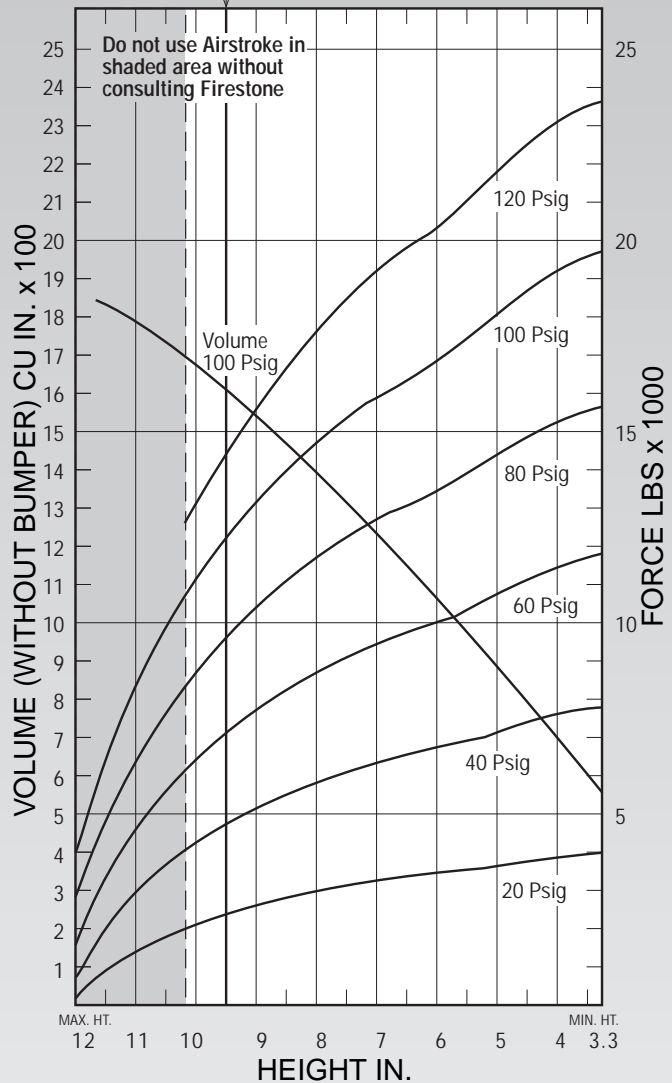

See page 12 for instructions on how to use chart.

Force Table (Use for Airstroke <sup>®</sup> actuator design)						
Assembly Height (in.)	Volume @ 100 PSIG (in <sup>3</sup> )	Pounds Force				
		@20 PSIG	@40 PSIG	@60 PSIG	@80 PSIG	@100 PSIG
10.0	1,658	2,090	4,150	6,410	8,780	11,100
9.0	1,529	2,500	5,000	7,550	10,290	13,010
8.0	1,384	2,840	5,700	8,530	11,530	14,550
7.0	1,224	3,110	6,250	9,340	12,580	15,790
6.0	1,053	3,330	6,650	9,940	13,380	16,760
5.0	871	3,590	7,130	10,690	14,380	18,010
4.0	679	3,820	7,570	11,360	15,270	19,130

Description		Assembly Order No.
Style 203	Ribbed neck aluminum bead rings (equal spacing), 1 7/8 bolts, nuts, washers	WO1-358-7227
Two Ply Bellows	Ribbed neck aluminum bead rings (equal spacing) 1 1/4 b,n,w	WO1-358-7225
	Rolled plate assembly, 1/2 blind but 3/4 NPT	WO1-358-7273
	Rubber bellows only	WO1-358-0205
Assembly weight .....		23.8 lbs
Force to collapse to minimum height (@ 0 PSIG).....		40 lbs.

Style 218	Ribbed neck aluminum bead rings (equal spacing)	
High Strength Bellows	1 7/8 bolts, nuts, washers	
		WO1-358-7228

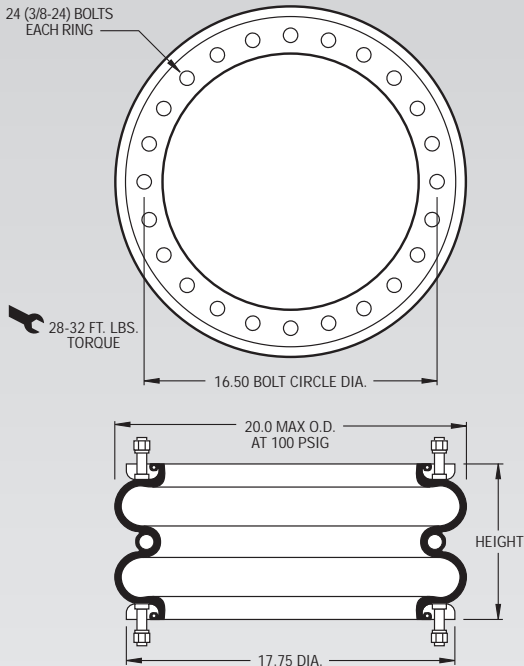

**NOTE: A bead ring part is shown. This part is also available with rolled plates. See page 11 for explanation.**

Dynamic Characteristics at 9.5 in. Design Height (Required for Airmount isolator design only)				
Volume @ 100 PSIG = 2,163 in <sup>3</sup>			Natural Frequency	
Gage Pressure (PSIG)	Load (lbs.)	Spring Rate (lbs./in.)	CPM	HZ
40	7,210	2,190	103	1.72
60	11,100	3,150	100	1.67
80	14,970	4,040	97	1.62
100	18,890	4,971	96	1.60

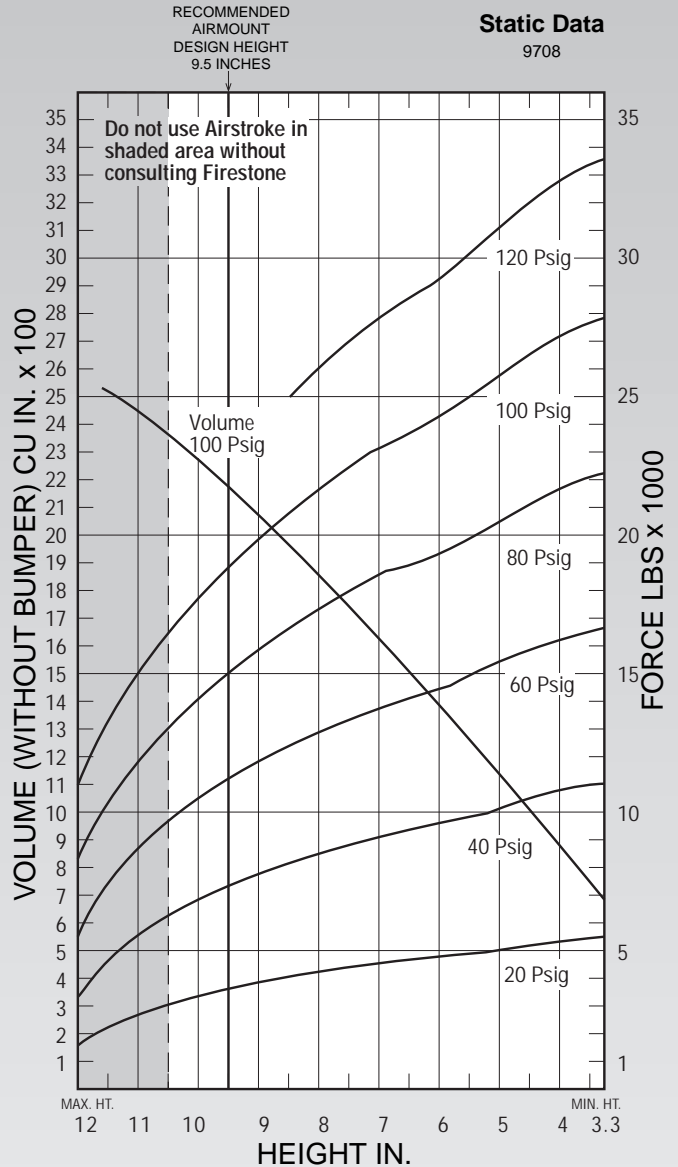

See page 12 for instructions on how to use chart.

Force Table (Use for Airstroke® actuator design)						
Assembly Height (in.)	Volume @ 100 PSIG (in <sup>3</sup> )	Pounds Force				
		@20 PSIG	@40 PSIG	@60 PSIG	@80 PSIG	@100 PSIG
10.0	2,261	3,330	6,710	10,340	14,000	17,680
9.0	2,067	3,820	7,680	11,780	15,850	19,970
8.0	1,853	4,210	8,450	12,880	17,370	21,840
7.0	1,625	4,520	9,010	13,700	18,590	23,280
6.0	1,385	4,790	9,510	14,460	19,490	24,360
5.0	1,135	5,070	10,140	15,380	20,580	25,790
4.0	870	5,350	10,760	16,260	21,750	27,240

Description		Assembly Order No.
Style 29	Ribbed neck aluminum bead rings (equal spacing), 1 7/8 bolts, nuts, washers	WO1-358-7203
Two Ply Bellows	Ribbed neck aluminum bead rings (unequal spacing) 1 7/8 b,n,w	WO1-358-7205
	Ribbed neck aluminum bead rings (equal spacing) 1 1/4 b,n,w	WO1-358-7201
	Rolled plate assembly, 1/2 blind nuts 3/4 NPT	WO1-358-7275
	Rubber bellows only	WO1-358-7902
Assembly weight .....		28.8 lbs
Force to collapse to minimum height (@ 0 PSIG).....		70 lbs.

Style 207	Ribbed neck aluminum bead rings (equal spacing), 1 7/8 bolts, nuts, washers	WO1-358-7242
High Strength Bellows	Ribbed neck aluminum bead rings (unequal spacing) 1 7/8 b,n,w	WO1-358-7239
	Rubber bellows only	WO1-139-0207

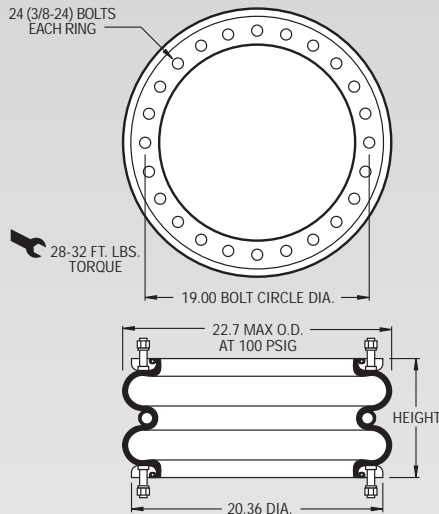

**NOTE: A bead ring part is shown. This part is also available with rolled plates. See page 11 for explanation**

Dynamic Characteristics at 9.5 in. Design Height (Required for Airmount isolator design only)				
Volume @ 100 PSIG = 2,934 in <sup>3</sup>			Natural Frequency	
Gage Pressure (PSIG)	Load (lbs.)	Spring Rate (lbs./in.)	CPM	HZ
40	9,780	2,752	96	1.60
60	14,860	3,737	94	1.57
80	20,060	4,844	92	1.54
100	25,350	5,917	91	1.51

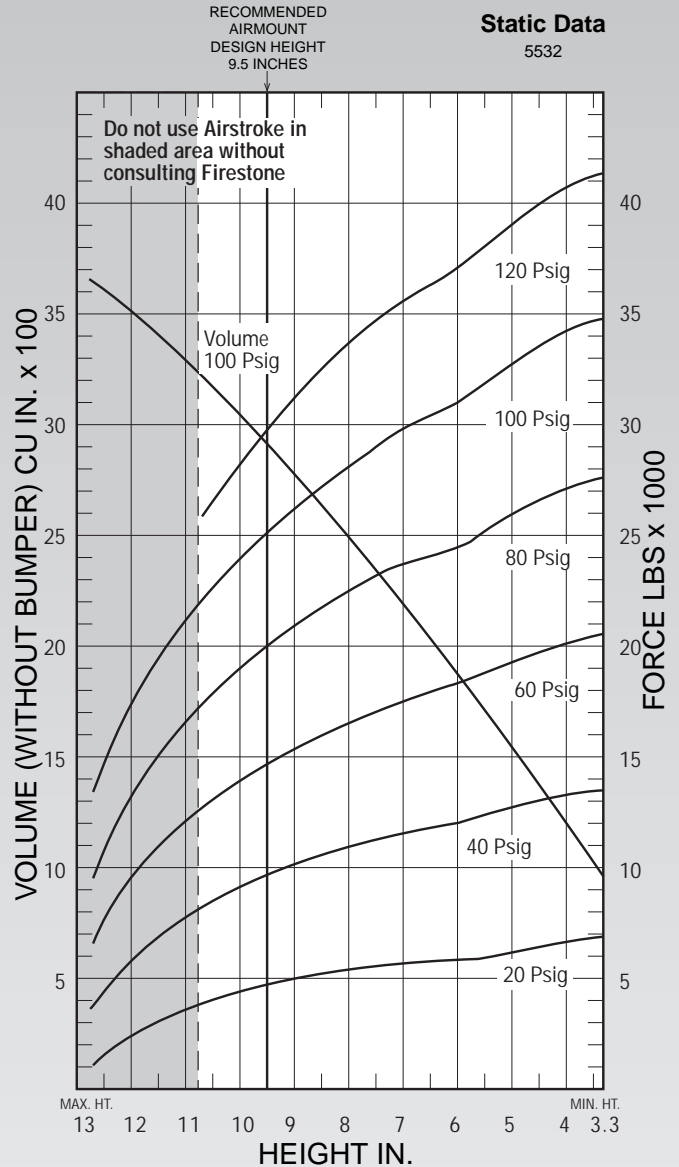

See page 12 for instructions on how to use chart.

Force Table (Use for Airstroke <sup>®</sup> actuator design)						
Assembly Height (in.)	Volume @ 100 PSIG (in <sup>3</sup> )	Pounds Force				
		@20 PSIG	@40 PSIG	@60 PSIG	@80 PSIG	@100 PSIG
10.0	3,064	4,480	9,320	14,130	19,110	24,190
9.0	2,796	4,990	10,200	15,520	20,940	26,410
8.0	2,512	5,440	10,990	16,680	22,480	28,270
7.0	2,206	5,780	11,650	17,620	23,740	29,830
6.0	1,889	5,950	12,090	18,330	24,640	31,000
5.0	1,559	6,310	12,720	19,340	26,040	32,740
4.0	1,211	6,650	13,320	20,150	27,140	34,100

Description		Assembly Order No.
Style 200	Ribbed neck aluminum bead rings (equal spacing), 1 7/8 bolts, nuts, washers	WO1-358-7772
Two Ply Bellows	Ribbed neck aluminum bead rings (equal spacing) 1 1/4 b,n,w Rubber bellows only	WO1-358-7775 WO1-358-5126
Assembly weight .....		34.9 lbs
Force to collapse to minimum height (@ 0 PSIG).....		100 lbs.

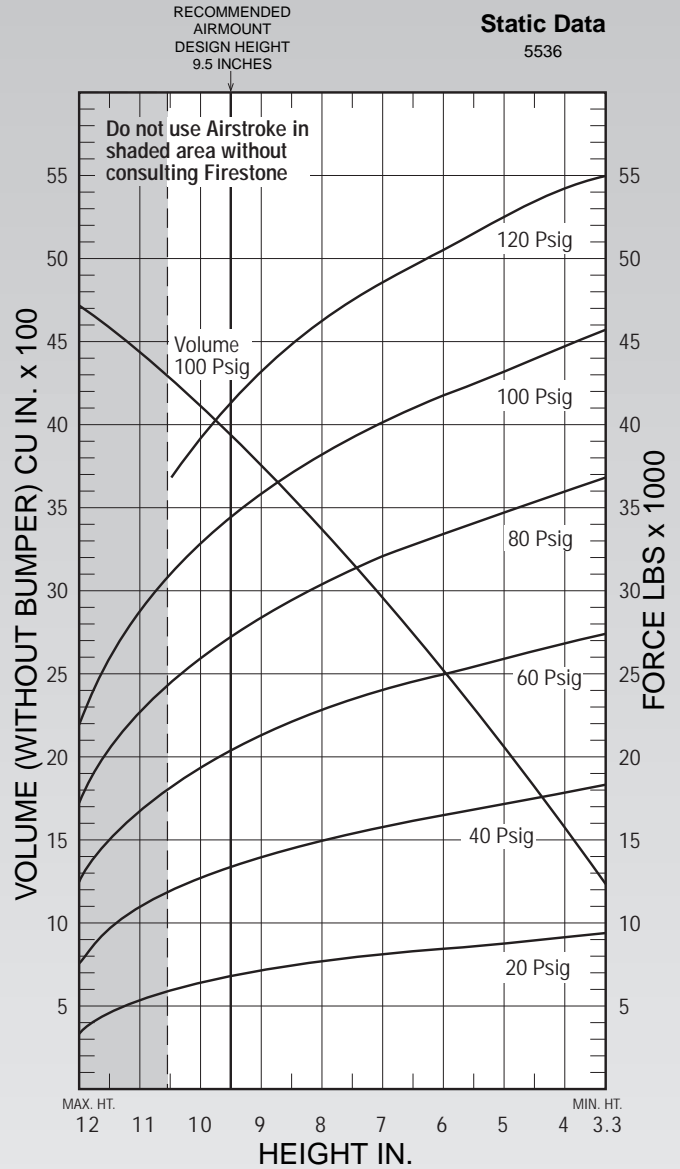
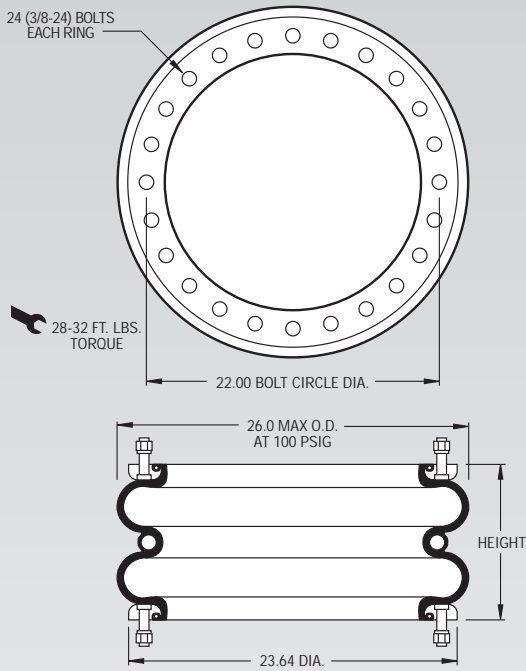

See page 12 for instructions on how to use chart.

Dynamic Characteristics at 9.5 in. Design Height (Required for Airmount isolator design only)				
Volume @ 100 PSIG = 3,921 in <sup>3</sup>			Natural Frequency	
Gage Pressure (PSIG)	Load (lbs.)	Spring Rate (lbs./in.)	CPM	HZ
40	13,290	3,784	100	1.67
60	20,390	5,336	96	1.60
80	27,330	6,763	93	1.56
100	34,620	8,105	91	1.51

Force Table (Use for Airstroke® actuator design)						
Assembly Height (in.)	Volume @ 100 PSIG (in <sup>3</sup> )	Pounds Force				
		@20 PSIG	@40 PSIG	@60 PSIG	@80 PSIG	@100 PSIG
10.0	4,099	6,270	12,530	19,300	25,970	33,040
9.0	3,734	7,070	13,960	21,360	28,550	36,020
8.0	3,343	7,710	15,070	22,960	30,580	38,450
7.0	2,928	8,180	15,920	24,160	32,200	40,400
6.0	2,495	8,540	16,610	25,110	33,550	41,960
5.0	2,055	8,880	17,280	26,010	34,790	43,400
4.0	1,589	9,260	18,000	26,960	36,020	44,850

Description		Assembly Order No.
Style 215	Ribbed neck aluminum bead rings (equal spacing), 1 7/8 bolts, nuts, washers	WO1-358-7230
Two Ply High Strength Bellows	Ribbed neck aluminum bead rings (unequal spacing) 1 7/8 b,n,w	WO1-358-7301
	Ribbed neck aluminum bead rings (equal spacing) 1 1/4 b,n,w	WO1-358-7302
	Rubber bellows only	WO1-358-7912
Assembly weight . . . . .		38.4 lbs.
Force to collapse to minimum height (@ 0 PSIG).....		160 lbs.

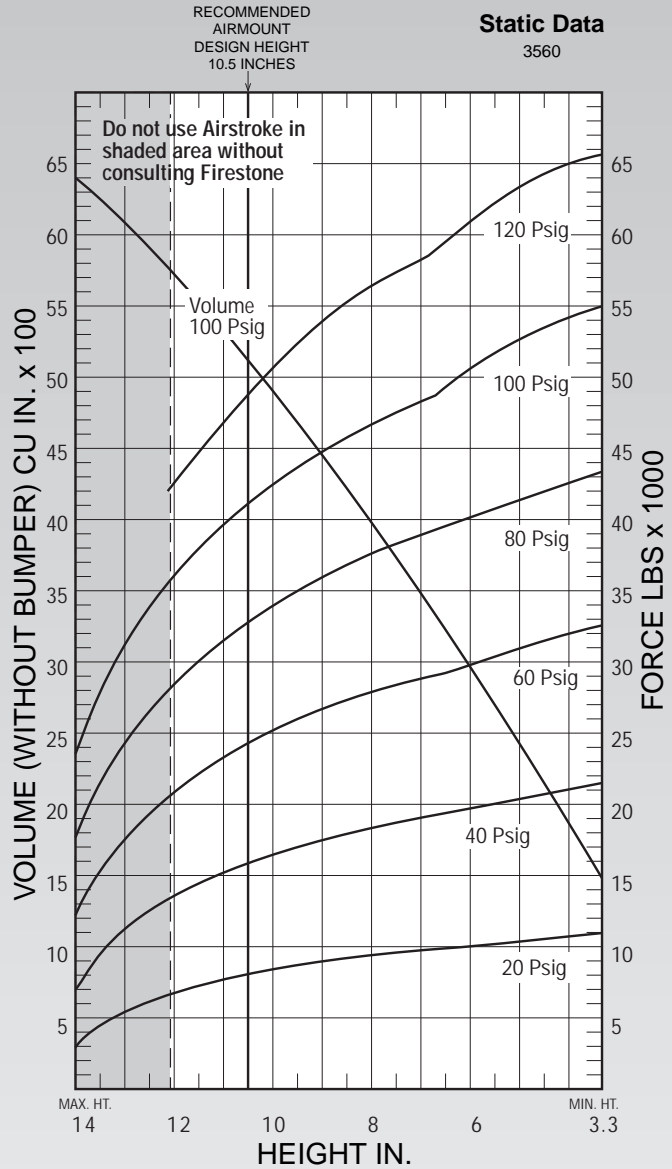
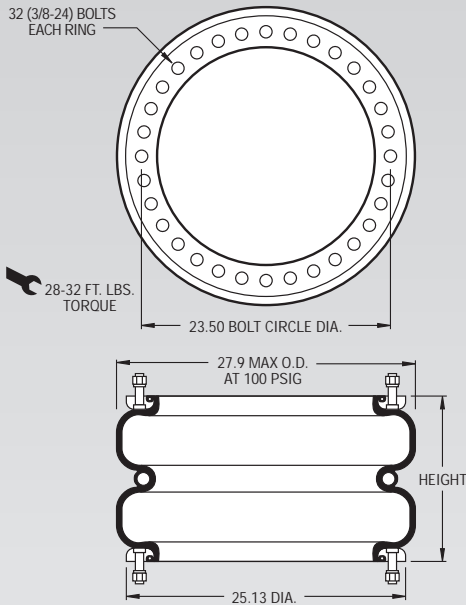

See page 12 for instructions on how to use chart.

Dynamic Characteristics at 10.5 in. Design Height (Required for Airmount isolator design only)				
Volume @ 100 PSIG = 5,094 in <sup>3</sup>			Natural Frequency	
Gage Pressure (PSIG)	Load (lbs.)	Spring Rate (lbs./in.)	CPM	HZ
40	15,840	3,858	93	1.54
60	24,140	5,370	88	1.47
80	32,550	6,857	86	1.44
100	40,980	8,203	84	1.40

Force Table (Use for Airstroke <sup>®</sup> actuator design)						
Assembly Height (in.)	Volume @ 100 PSIG (in <sup>3</sup> )	Pounds Force				
		@20 PSIG	@40 PSIG	@60 PSIG	@80 PSIG	@100 PSIG
12.0	5,701	6,520	13,310	20,720	28,410	36,100
10.0	4,882	8,170	16,480	25,050	33,720	42,350
8.0	3,964	9,120	18,460	27,920	37,570	47,010
6.0	2,973	9,910	19,940	30,070	40,430	51,100
4.0	1,907	10,790	21,290	31,970	42,980	54,390

Description		Assembly Order No.
Style 248-2	Ribbed neck aluminum bead rings (equal spacing), 1 7/8 bolts, nuts, washers	WO1-358-9602
Four Ply Bellows		
Assembly weight .....		72.5 lbs.
Force to collapse to minimum height (@ 0 PSIG).....		350 lbs.

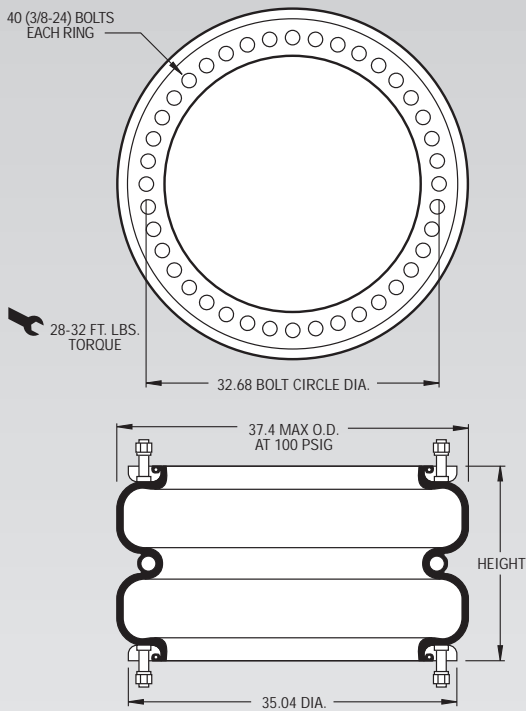

**NOTE:** The effective length of 1 7/8 bolt is 1.02" in this bead ring.

Dynamic Characteristics at 11.0 in. Design Height (Required for Airmount isolator design only)				
Volume @ 100 PSIG = 9,815 in <sup>3</sup>			Natural Frequency	
Gage Pressure (PSIG)	Load (lbs.)	Spring Rate (lbs./in.)	CPM	HZ
40	30,830	6,746	88	1.46
60	47,720	9,549	84	1.40
80	63,890	12,423	83	1.38
100	79,730	14,989	81	1.36

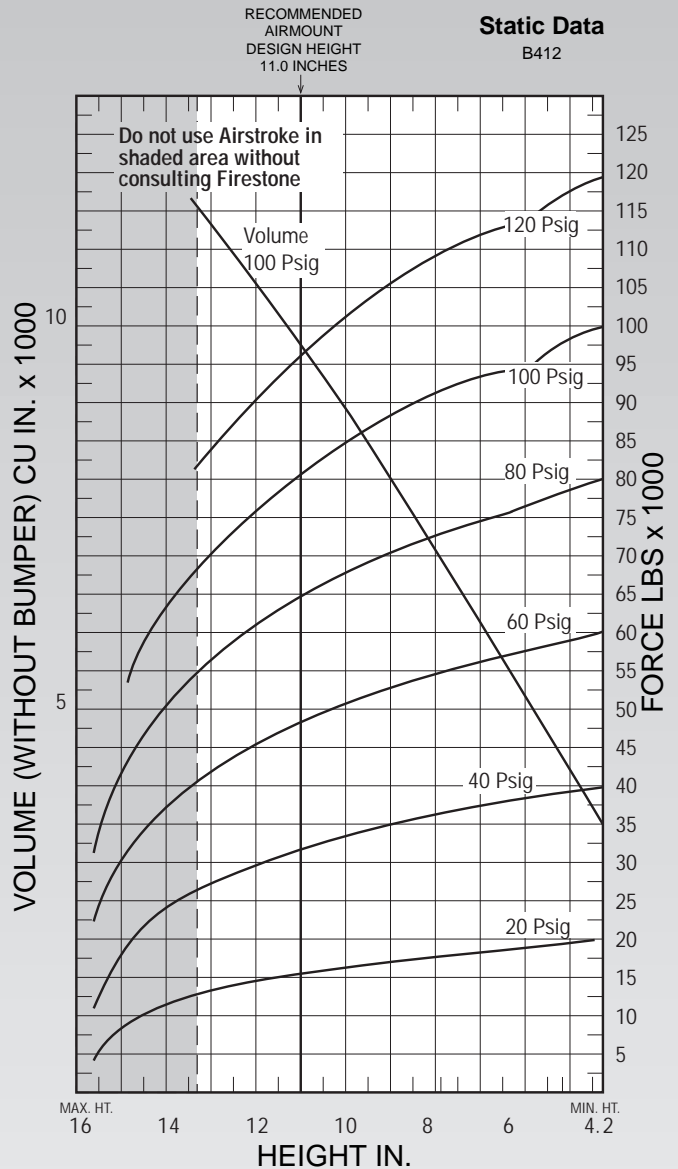

See page 12 for instructions on how to use chart.

Force Table (Use for Airstroke® actuator design)						
Assembly Height (in.)	Volume @ 100 PSIG (in <sup>3</sup> )	Pounds Force				
		@20 PSIG	@40 PSIG	@60 PSIG	@80 PSIG	@100 PSIG
13.0	11,386	12,660	26,460	41,020	55,290	69,700
11.0	9,815	15,200	30,830	47,720	63,890	79,730
9.0	8,090	16,890	34,210	52,080	69,850	87,790
7.0	6,243	18,210	37,030	55,570	74,410	93,230
5.0	4,304	19,270	38,820	58,730	78,570	98,180

Description		Assembly Order No.
Style 352	Blind nuts, 1/4 NPT	WO1-358-8048
	Blind nuts, 3/4 NPT	WO1-358-8047
Two Ply Bellows		
Assembly weight .....		20.3 lbs.
Force to collapse to minimum height (@ 0 PSIG).....		21 lbs.

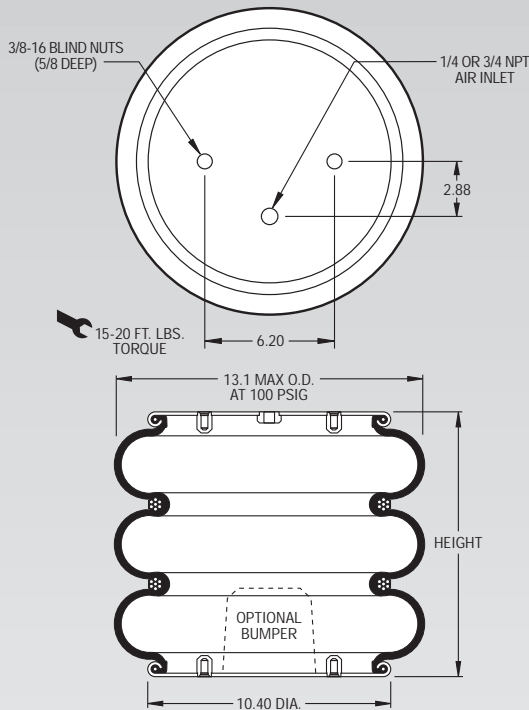

**NOTE:** A bead plate part is shown. This part is also available with bead rings. See pages 8-10 for explanation.

Dynamic Characteristics at 13.5 in. Design Height (Required for Airmount isolator design only)				
Volume @ 100 PSIG = 1,168 in <sup>3</sup>			Natural Frequency	
Gage Pressure (PSIG)	Load (lbs.)	Spring Rate (lbs./in.)	CPM	HZ
40	2,319	475	85.08	1.42
60	3,631	675	81.05	1.35
80	5,017	851	77.42	1.29
100	6,463	1,042	75.49	1.26

CONSULT FIRESTONE BEFORE USING AS AIRMOUNT

RECOMMENDED AIRMOUNT DESIGN HEIGHT 13.5 INCHES

**Static Data**  
B4789

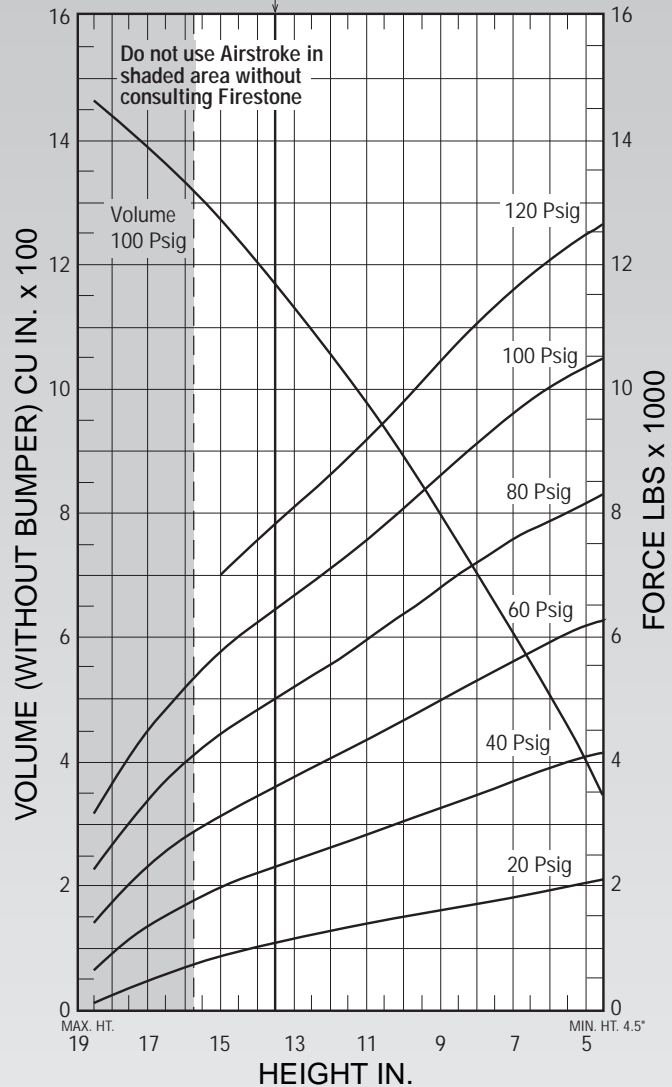

See page 12 for instructions on how to use chart.

Force Table (Use for Airstroke <sup>®</sup> actuator design)						
Assembly Height (in.)	Volume @ 100 PSIG (in <sup>3</sup> )	Pounds Force				
		@20 PSIG	@40 PSIG	@60 PSIG	@80 PSIG	@100 PSIG
16.0	1,330	679	1,695	2,780	4,000	5,221
14.0	1,203	1,015	2,211	3,480	4,838	6,248
12.0	1,057	1,278	2,622	4,068	5,557	7,104
10.0	892	1,497	3,025	4,662	6,365	8,069
8.0	708	1,700	3,457	5,296	7,201	9,127
6.0	507	1,917	3,896	5,910	7,881	10,030
5.0	400	2,040	4,095	6,169	8,165	10,363



Description		Assembly Order No.
Style 313	Blind nuts, 1/4 NPT	WO1-358-7808
	Blind nuts, 1/4 NPT, bumper	WO1-358-7811
Two Ply	Blind nuts, 3/4 NPT	WO1-358-7802
	Blind nuts, 3/4 NPT, bumper	WO1-358-7807
Bellows	Button head steel bead rings, 1 7/8 bolts, nuts, washers	WO1-358-7801
	Rubber bellows only	WO1-358-7900
Assembly weight .....		19.5 lbs
Force to collapse to minimum height (@ 0 PSIG).....		46 lbs.

Style 39	Blind nuts, 1/4 NPT	WO1-358-1098
	Blind nuts, 3/4 NPT	WO1-358-7815
High Strength Bellows	Button head steel bead rings, 1 7/8 bolts, nuts, washers	WO1-358-1099

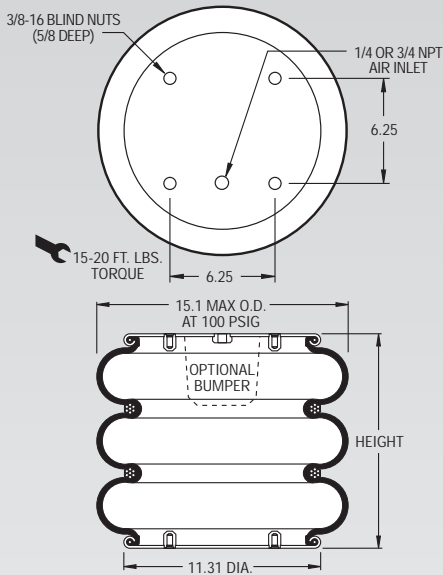

**NOTE: A bead plate part is shown. This part is also available with bead rings. See pages 8-10 for explanation.**

Dynamic Characteristics at 13.0 in. Design Height (Required for Airmount isolator design only)				
Volume @ 100 PSIG = 1,585 in <sup>3</sup>			Natural Frequency	
Gage Pressure (PSIG)	Load (lbs.)	Spring Rate (lbs./in.)	CPM	HZ
40	3,310	716	87	1.45
60	5,120	1,049	85	1.41
80	7,020	1,348	82	1.37
100	8,960	1,668	81	1.35

CONSULT FIRESTONE BEFORE USING AS AIRMOUNT

RECOMMENDED AIRMOUNT DESIGN HEIGHT 13.0 INCHES

Static Data  
1841

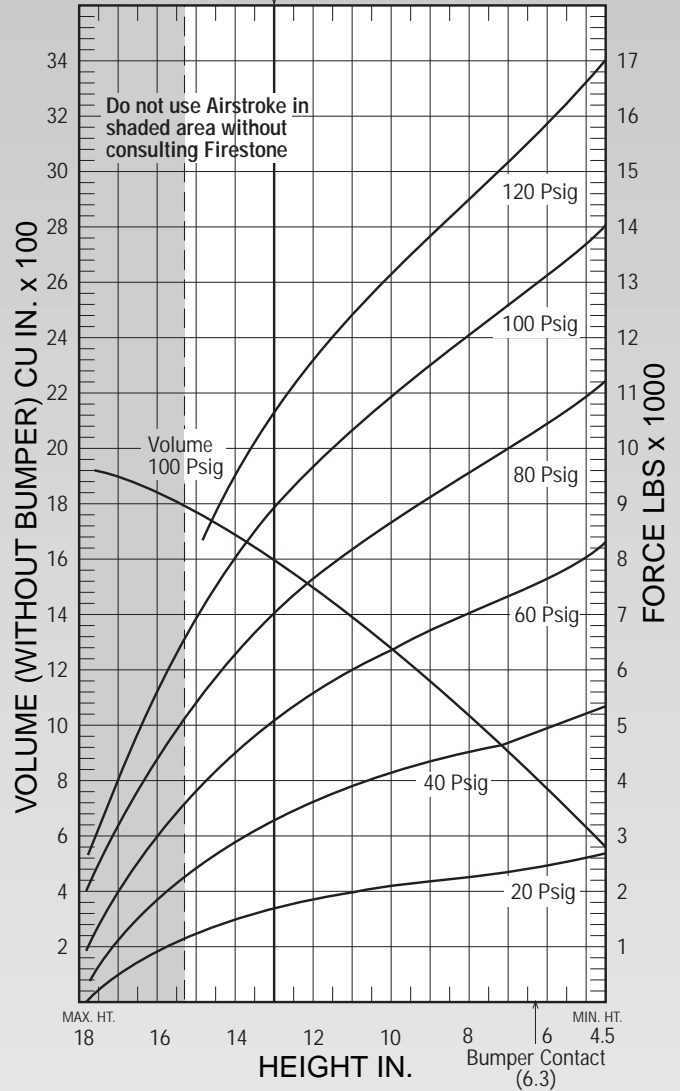

See page 12 for instructions on how to use chart.

Force Table (Use for Airstroke® actuator design)						
Assembly Height (in.)	Volume @ 100 PSIG (in <sup>3</sup> )	Pounds Force				
		@20 PSIG	@40 PSIG	@60 PSIG	@80 PSIG	@100 PSIG
15.0	1,760	1,280	2,500	3,870	5,470	7,040
13.0	1,585	1,710	3,310	5,120	7,020	8,960
11.0	1,379	1,970	3,920	6,030	8,200	10,360
9.0	1,149	2,140	4,340	6,710	9,120	11,480
7.0	898	2,350	4,730	7,290	9,920	12,510
5.0	625	2,640	5,230	8,050	10,940	13,670

Description		Assembly Order No.
Style 333	Blind nuts, 1/4 NPT	WO1-358-7845
	Blind nuts, 3/4 NPT	WO1-358-7842
Two Ply Bellows	Blind nuts, 1/4 NPT, bumper	WO1-358-7838
	Button head steel bead ring 1 7/8 bolts, nuts, washers	WO1-358-7830
	Rubber bellows only	WO1-358-7019
	Assembly weight .....	24.6 lbs.
Force to collapse to minimum height (@ 0 PSIG).....		65 lbs.

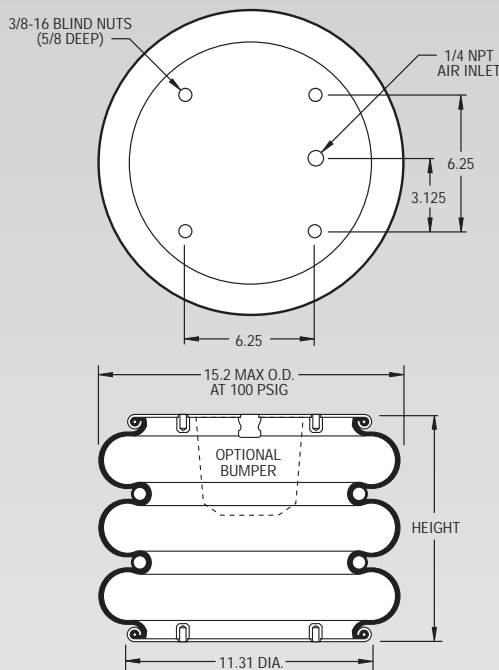

**NOTE: A bead plate part is shown. This part is also available with bead rings. See pages 8-10 for explanation.**

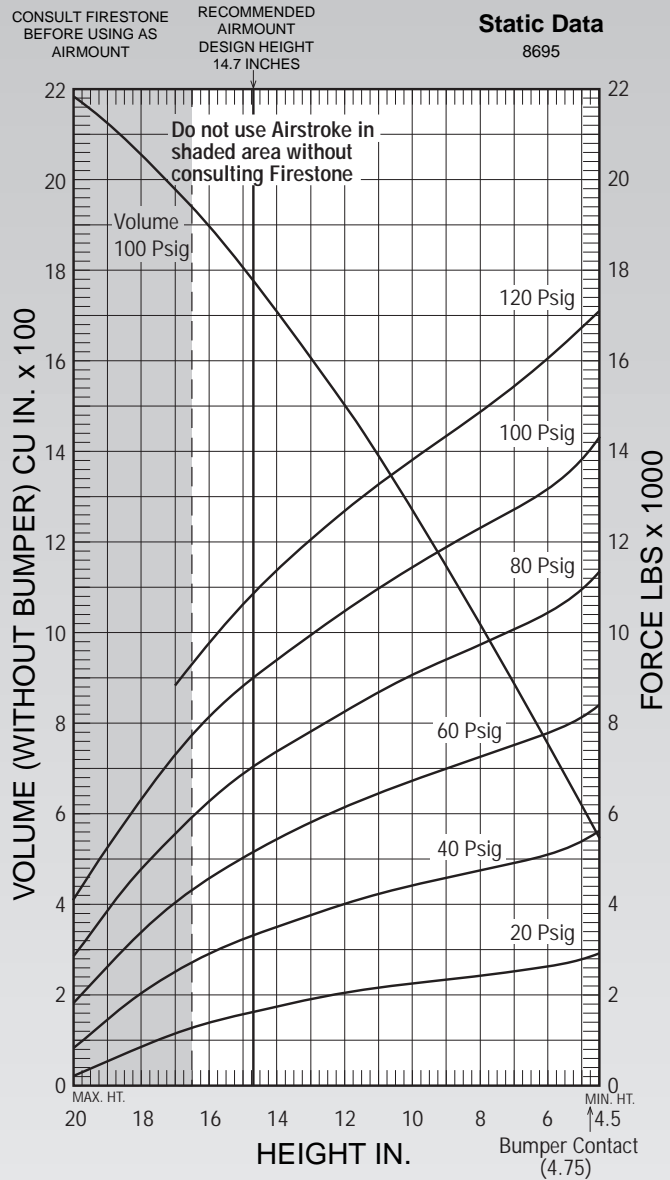

See page 12 for instructions on how to use chart.

Dynamic Characteristics at 14.70 in. Design Height (Required for Airmount isolator design only)				
Volume @ 100 PSIG = 1,786 in <sup>3</sup>			Natural Frequency	
Gage Pressure (PSIG)	Load (lbs.)	Spring Rate (lbs./in.)	CPM	HZ
40	3,282	685	86	1.43
60	5,167	933	80	1.33
80	7,000	1,179	77	1.28
100	8,940	1,425	75	1.25

Force Table (Use for Airstroke <sup>®</sup> actuator design)						
Assembly Height (in.)	Volume @ 100 PSIG (in <sup>3</sup> )	Pounds Force				
		@20 PSIG	@40 PSIG	@60 PSIG	@80 PSIG	@100 PSIG
16.0	1,904	1,338	2,866	4,524	6,241	8,062
14.0	1,718	1,706	3,478	5,388	7,325	9,338
12.0	1,507	1,981	3,955	6,083	8,200	10,405
10.0	1,274	2,208	4,376	6,698	9,003	11,400
8.0	1,022	2,389	4,733	7,220	9,710	12,278
6.0	754	2,574	5,087	7,724	10,396	13,139
4.0	473	3,049	5,871	8,787	11,827	14,918

Description		Assembly Order No.
Style 312	Ribbed neck aluminum bead rings (equal spacing), 1 7/8 bolts, nuts, washers	WO1-358-7761
Two Ply Bellows	Ribbed neck aluminum bead rings (unequal spacing) 1 7/8 b,n,w	WO1-358-7760
	Rolled plate assembly, 1/2 blind nuts, 3/4 NPT	WO1-358-7286
	Rubber bellows only	WO1-358-7914
Assembly weight .....		24.8 lbs
Force to collapse to minimum height (@ 0 PSIG).....		135 lbs.

Style 314	Ribbed neck aluminum bead rings (equal spacing), 1 7/8 bolts, nuts, washers	WO1-358-8003
High Strength Bellows	Ribbed neck aluminum bead rings (unequal spacing) 1 7/8 b,n,w	WO1-358-8004
	Rolled plate assembly, 1/2 blind nuts, 3/4 NPT	WO1-358-8009
	Rubber bellows only	WO1-358-7926

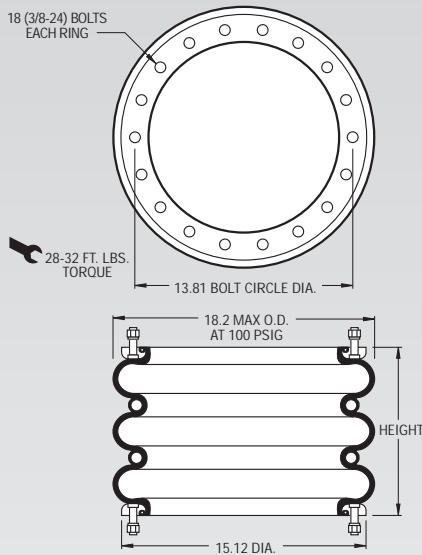

**NOTE: A bead ring part is shown. This part is also available with rolled plates. See page 11 for explanation.**

Dynamic Characteristics at 13.0 in. Design Height (Required for Airmount isolator design only)				
Volume @ 100 PSIG = 2,207 in <sup>3</sup>			Natural Frequency	
Gage Pressure (PSIG)	Load (lbs.)	Spring Rate (lbs./in.)	CPM	HZ
40	5,100	1,056	85	1.42
60	7,930	1,536	83	1.38
80	10,730	1,950	80	1.33
100	13,530	2,371	79	1.31

CONSULT FIRESTONE BEFORE USING AS AIRMOUNT  
RECOMMENDED AIRMOUNT DESIGN HEIGHT 13.0 INCHES  
**Static Data**  
1909

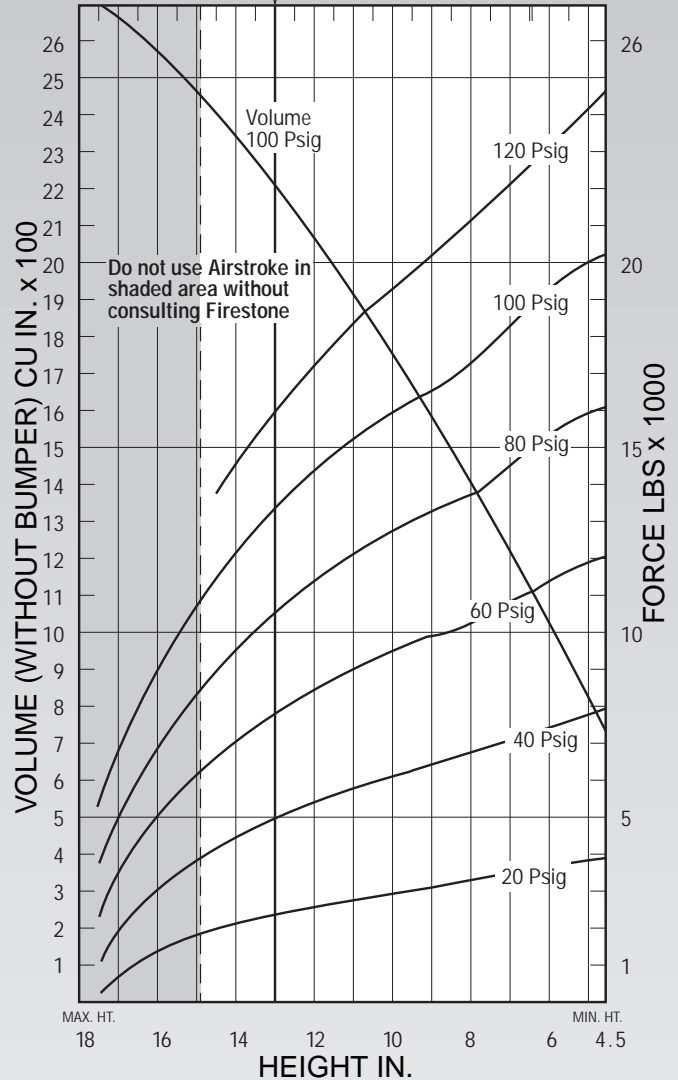

See page 12 for instructions on how to use chart.

Force Table (Use for Airstroke® actuator design)						
Assembly Height (in.)	Volume @ 100 PSIG (in <sup>3</sup> )	Pounds Force				
		@20 PSIG	@40 PSIG	@60 PSIG	@80 PSIG	@100 PSIG
14.0	2,342	2,300	4,640	7,230	9,820	12,420
12.0	2,061	2,760	5,510	8,560	11,510	14,450
10.0	1,744	3,130	6,260	9,620	12,870	16,060
8.0	1,400	3,340	6,940	10,370	13,820	17,440
6.0	1,021	3,790	7,580	11,510	15,350	19,280

Description		Assembly Order No.
Style 323	Ribbed neck aluminum bead rings (equal spacing), 1 7/8 bolts, nuts, washers	WO1-358-7823
Two Ply Bellows	Rolled plate assembly, 1/2 blind nuts, 3/4 NPT	WO1-358-7274
	Rubber bellows only	WO1-358-7921
Assembly weight .....		31.1 lbs
Force to collapse to minimum height (@ 0 PSIG).....		70 lbs.

Style 324	Ribbed neck aluminum bead rings (equal spacing), 1 7/8 bolts, nuts, washers	WO1-358-7829
High Strength Bellows	Rubber bellows only	WO1-358-0324

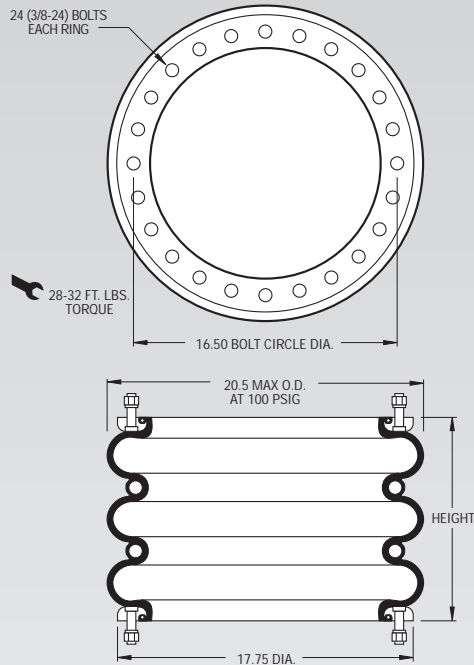

**NOTE: A bead ring part is shown. This part is also available with rolled plates. See page 11 for explanation.**

Dynamic Characteristics at 13.0 in. Design Height (Required for Airmount isolator design only)				
Volume @ 100 PSIG = 3,109 in <sup>3</sup>			Natural Frequency	
Gage Pressure (PSIG)	Load (lbs.)	Spring Rate (lbs./in.)	CPM	HZ
40	7,380	1,487	84	1.40
60	11,520	2,080	80	1.33
80	15,550	2,652	77	1.29
100	19,660	3,399	78	1.30

CONSULT FIRESTONE BEFORE USING AS AIRMOUNT

RECOMMENDED AIRMOUNT DESIGN HEIGHT 13.0 INCHES

**Static Data**  
1808

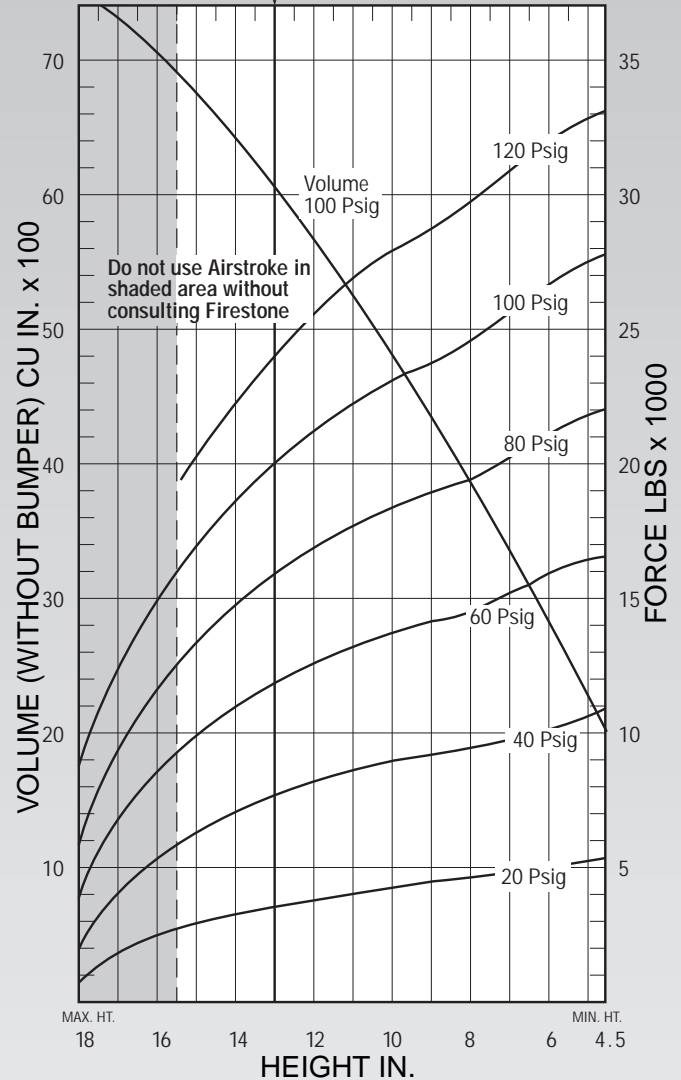

See page 12 for instructions on how to use chart.

Force Table (Use for Airstroke <sup>®</sup> actuator design)						
Assembly Height (in.)	Volume @ 100 PSIG (in <sup>3</sup> )	Pounds Force				
		@20 PSIG	@40 PSIG	@60 PSIG	@80 PSIG	@100 PSIG
15.0	3,496	2,940	6,160	9,810	13,170	16,620
13.0	3,109	3,490	7,380	11,520	15,550	19,660
11.0	2,673	3,970	8,400	12,910	17,270	21,910
9.0	2,201	4,330	9,150	13,890	18,650	23,500
7.0	1,698	4,670	9,660	14,850	19,890	25,140
5.0	1,155	5,160	10,360	16,050	21,470	26,970

Description		Assembly Order No.
Style 320	Ribbed neck aluminum bead rings (equal spacing), 1 7/8 bolts, nuts, washers	WO1-358-7324
Two Ply Bellows	Rolled plate assembly, 1/2 blind nuts, 3/4 NPT	WO1-358-7276
	Rubber bellows only	WO1-358-0987
Assembly weight .....		36.3 lbs
Force to collapse to minimum height (@ 0 PSIG).....		90 lbs.

Style 328	Ribbed neck aluminum bead rings (equal spacing), 1 7/8 bolts, nuts, washers	WO1-358-9528
High Strength Bellows		

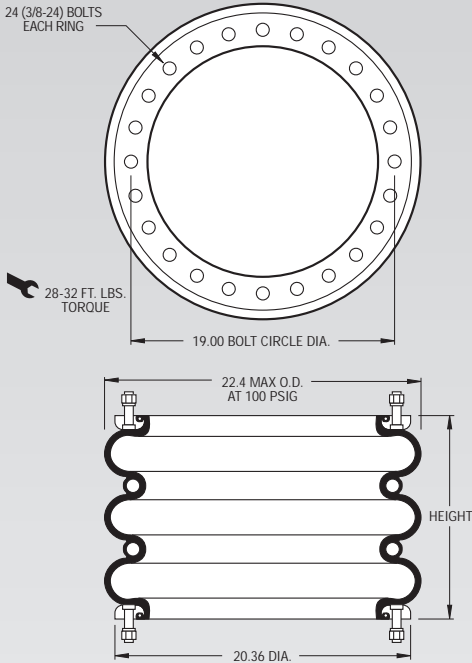

**NOTE: A bead ring part is shown. This part is also available with rolled plates. See page 11 for explanation.**

Dynamic Characteristics at 14.0 in. Design Height (Required for Airmount isolator design only)				
Volume @ 100 PSIG = 4,328 in <sup>3</sup>			Natural Frequency	
Gage Pressure (PSIG)	Load (lbs.)	Spring Rate (lbs./in.)	CPM	HZ
40	10,340	1,794	78	1.30
60	15,580	2,503	75	1.25
80	21,080	3,225	73	1.22
100	26,740	3,981	72	1.21

CONSULT FIRESTONE BEFORE USING AS AIRMOUNT

RECOMMENDED AIRMOUNT DESIGN HEIGHT 14.0 INCHES

**Static Data**  
5282

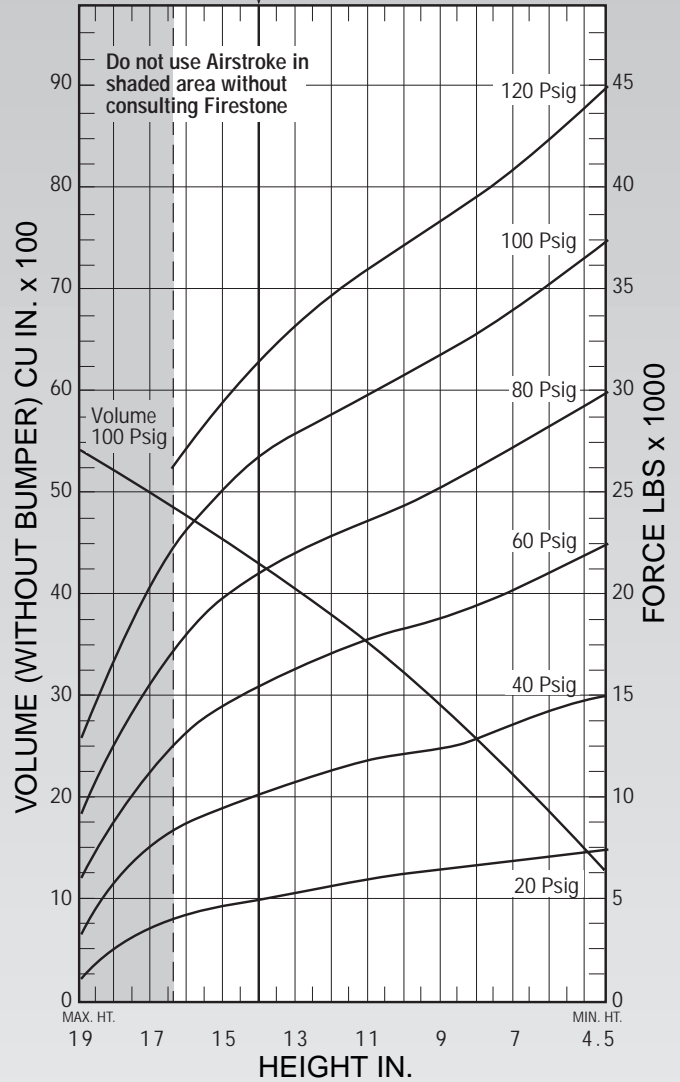

See page 12 for instructions on how to use chart.

Force Table (Use for Airstroke® actuator design)						
Assembly Height (in.)	Volume @ 100 PSIG (in <sup>3</sup> )	Pounds Force				
		@20 PSIG	@40 PSIG	@60 PSIG	@80 PSIG	@100 PSIG
16.0	4,833	4,330	8,900	13,420	18,120	23,110
14.0	4,328	5,110	10,340	15,580	21,080	26,740
12.0	3,780	5,750	11,470	17,210	22,950	29,000
10.0	3,180	6,230	12,330	18,570	24,580	30,910
8.0	2,544	6,580	12,930	19,530	26,280	32,920
6.0	1,856	7,050	14,230	21,260	28,220	35,270

Description		Assembly Order No.
Style 321	Ribbed neck aluminum bead rings (equal spacing), 1 7/8 bolts, nuts, washers	WO1-358-7304
Two Ply High Strength Bellows	Ribbed neck aluminum bead rings (unequal spacing) 1 7/8 b,n,w Rubber bellows only	WO1-358-7306 WO1-358-7919
Assembly weight .....		103.9 lbs
Force to collapse to minimum height (@ 0 PSIG).....		380 lbs.

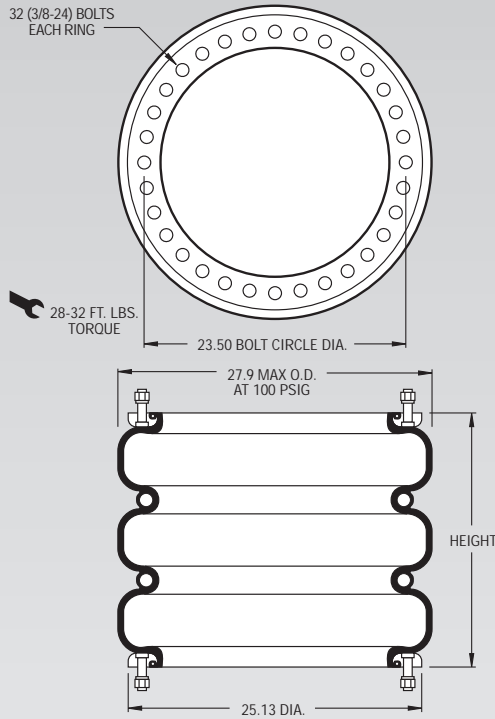

CONSULT FIRESTONE BEFORE USING AS AIRMOUNT

RECOMMENDED AIRMOUNT DESIGN HEIGHT 15.0 INCHES

**Static Data**  
1229

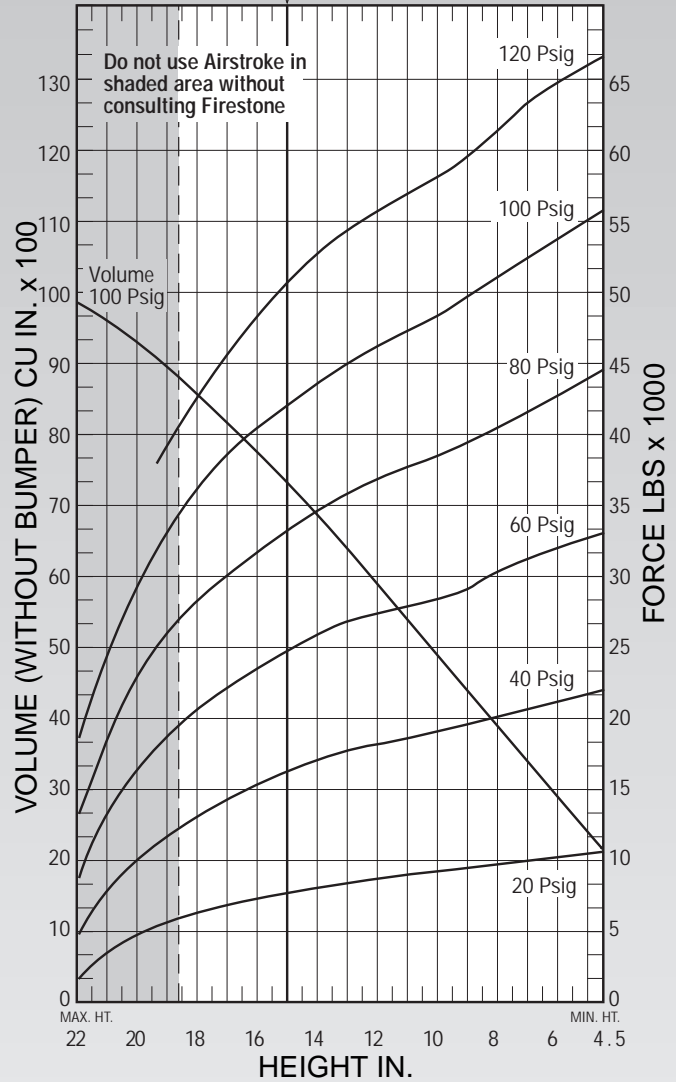

See page 12 for instructions on how to use chart.

Dynamic Characteristics at 15.0 in. Design Height (Required for Airmount isolator design only)				
Volume @ 100 PSIG = 7,346 in <sup>3</sup>			Natural Frequency	
Gage Pressure (PSIG)	Load (lbs.)	Spring Rate (lbs./in.)	CPM	HZ
40	16,220	2,538	74	1.24
60	24,690	3,623	72	1.20
80	33,290	4,624	70	1.17
100	41,900	5,620	69	1.15

Force Table (Use for Airstroke <sup>®</sup> actuator design)						
Assembly Height (in.)	Volume @ 100 PSIG (in <sup>3</sup> )	Pounds Force				
		@20 PSIG	@40 PSIG	@60 PSIG	@80 PSIG	@100 PSIG
18.0	8,561	6,400	13,320	20,620	28,020	35,660
16.0	7,770	7,510	15,410	23,490	31,760	40,060
14.0	6,904	8,200	16,890	25,740	34,610	43,510
12.0	5,983	8,710	17,960	27,350	36,690	46,120
10.0	5,019	9,240	18,830	28,410	38,280	48,150
8.0	4,007	9,790	19,850	30,160	40,510	50,860
6.0	2,944	10,260	20,990	32,110	42,880	53,710

Description		Assembly Order No.
Style 348-3	Ribbed neck aluminum bead rings (equal spacing), 1 7/8 bolts, nuts, washers	WO1-358-9603
High Strength Bellows	Rubber bellows only	WO1-358-1023
Assembly weight .....		103.9 lbs
Force to collapse to minimum height (@ 0 PSIG).....		380 lbs.

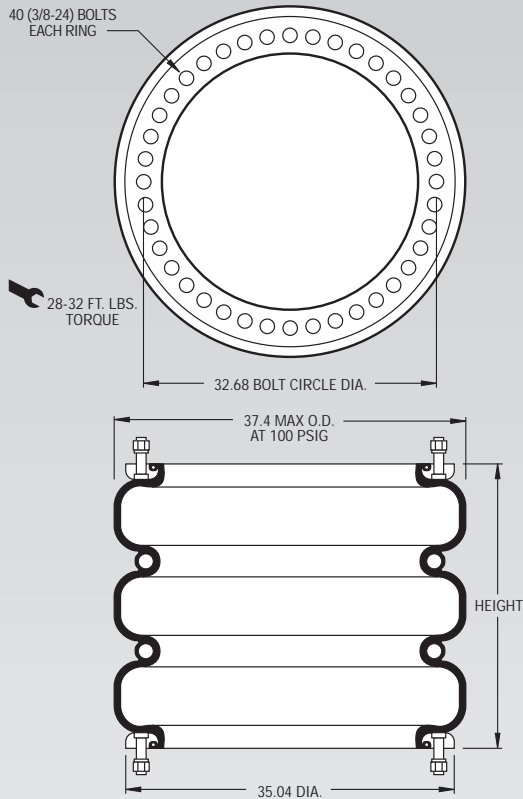

**NOTE:** The effective length of the 1 7/8 bolt is 1.02" in this bead ring.

Dynamic Characteristics at 15.0 in. Design Height (Required for Airmount isolator design only)				
Volume @ 100 PSIG = 13,501 in <sup>3</sup>			Natural Frequency	
Gage Pressure (PSIG)	Load (lbs.)	Spring Rate (lbs./in.)	CPM	HZ
40	31,480	4,761	73	1.22
60	47,870	6,586	70	1.16
80	64,870	8,614	68	1.14
100	82,540	10,592	67	1.12

CONSULT FIRESTONE BEFORE USING AS AIRMOUNT

RECOMMENDED AIRMOUNT DESIGN HEIGHT 15.0 INCHES

**Static Data**  
8413

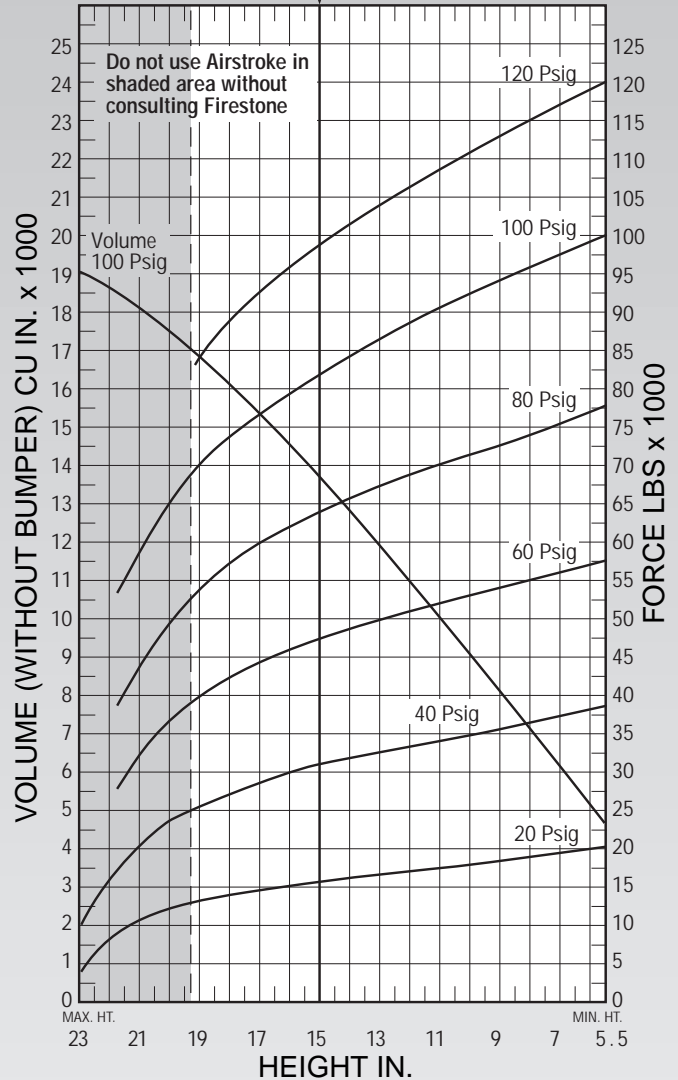

See page 12 for instructions on how to use chart.

Force Table (Use for Airstroke® actuator design)						
Assembly Height (in.)	Volume @ 100 PSIG (in <sup>3</sup> )	Pounds Force				
		@20 PSIG	@40 PSIG	@60 PSIG	@80 PSIG	@100 PSIG
18.0	15,946	14,080	27,430	43,790	57,710	74,670
16.0	14,340	15,190	30,370	46,420	62,810	80,190
14.0	12,634	16,230	32,380	49,170	66,610	84,820
12.0	10,843	17,330	33,880	51,470	69,410	89,150
10.0	8,984	18,290	35,370	53,580	71,930	93,030
8.0	7,075	19,070	36,970	55,590	74,740	96,470
6.0	5,102	19,760	38,620	57,550	77,790	99,680

# 1X84D-1 Firestone



## AIRMOUNT ISOLATOR ONLY

Description		Assembly Order No.
Style 1X84D-1	Thin wall assembly, without cap	WO1-358-9188
Thin wall Two Ply Bellows	Thin wall assembly, with cap (dotted line)	WO1-358-9190
	Thin wall rubber bellows only	WO1-358-0480
Assembly weight .....		2.6 lbs.

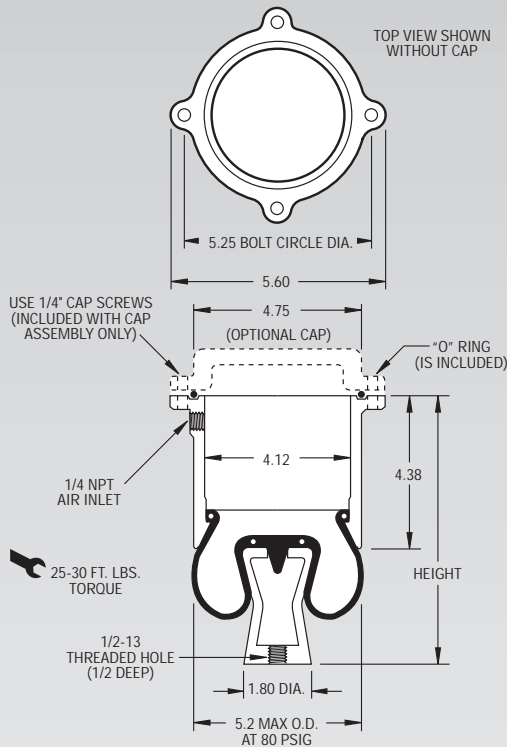

**NOTE: Do not exceed 80 PSIG.**

**NOTE: Do not use as an Airstroke actuator.**

RECOMMENDED AIRMOUNT DESIGN HEIGHT 8.0 INCHES

**Static Data**  
R9260

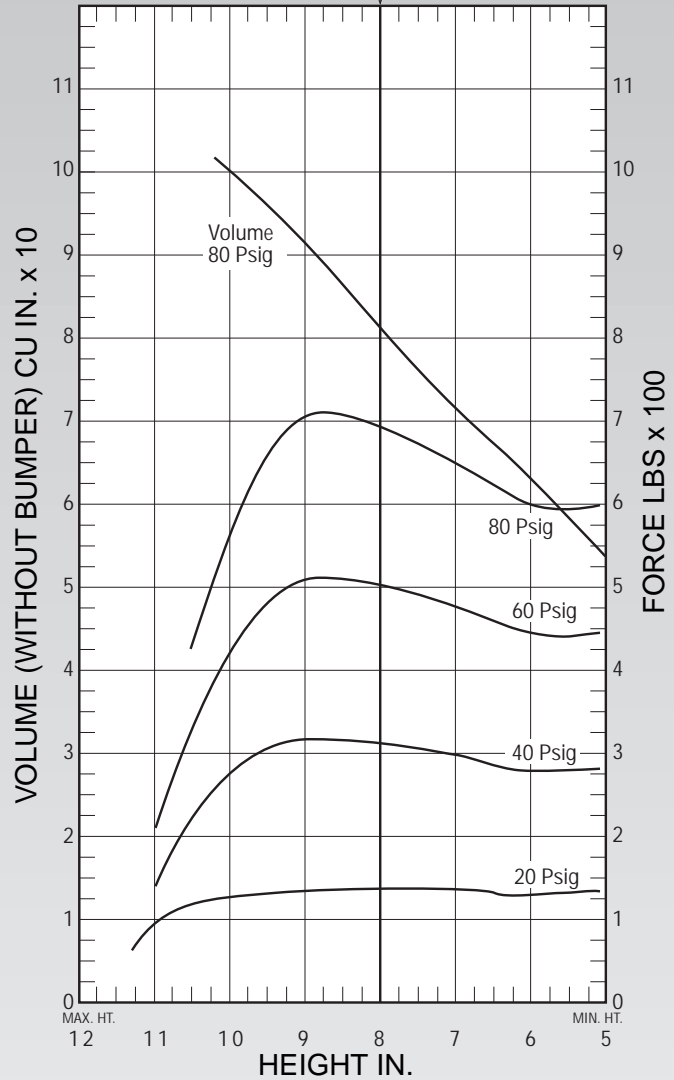

See page 12 for instructions on how to use chart.

Dynamic Characteristics at 8.0 in. Design Height (Required for Airmount isolator design only)				
Volume @ 80 PSIG = 81 in <sup>3</sup>			Natural Frequency	
Gage Pressure (PSIG)	Load (lbs.)	Spring Rate (lbs./in.)	CPM	HZ
40	310	58	81	1.35
60	500	77	74	1.23
80	680	96	71	1.18

**NOTE:**  
**Do not use as an Airstroke actuator.**



Description		Assembly Order No.
Style 4001	Blind nut, 1/8 NPT	WO2-358-4001
Two Ply Bellows		
Assembly weight .....		1.0 lbs.

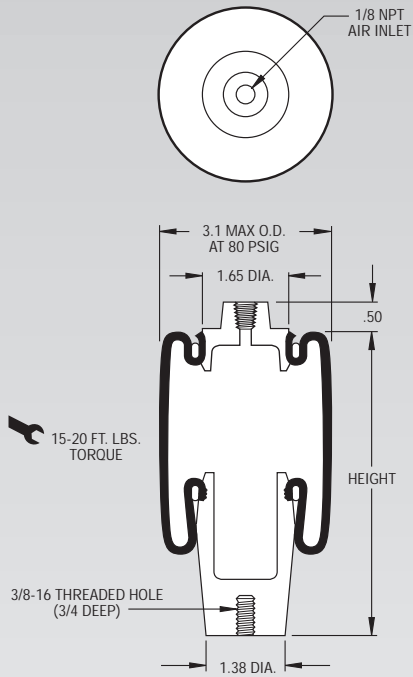

**NOTE:** Bellows will not compress properly with less than 10 PSIG internal pressure.

Dynamic Characteristics at 5.5 in. Design Height (Required for Airmount isolator design only)				
Volume @ 80 PSIG = 20 in <sup>3</sup>			Natural Frequency	
Gage Pressure (PSIG)	Load (lbs.)	Spring Rate (lbs./in.)	CPM	HZ
40	150	55	113	1.88
60	220	70	107	1.78
80	290	91	105	1.74
100	380	99	95	1.59

CONSULT FIRESTONE BEFORE USING AS AIRMOUNT

RECOMMENDED AIRMOUNT DESIGN HEIGHT 5.5 INCHES

**Static Data**  
8611

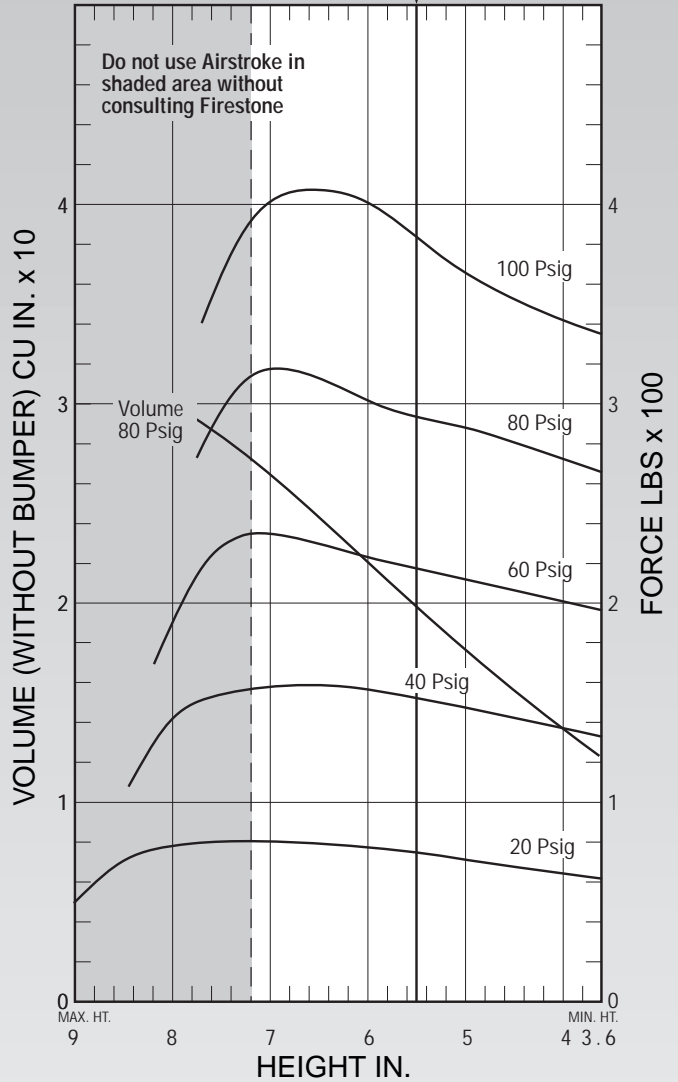

See page 12 for instructions on how to use chart.

Force Table (Use for Airstroke® actuator design)						
Assembly Height (in.)	Volume @ 80 PSIG (in <sup>3</sup> )	Pounds Force				
		@20 PSIG	@40 PSIG	@60 PSIG	@80 PSIG	@100 PSIG
7.0	26	80	160	230	320	410
6.0	22	80	160	220	300	400
5.0	18	70	150	210	290	370
4.0	14	60	140	200	270	340

# 7002

# Firestone

# AIRSTROKE<sup>®</sup>

ACTUATORS

# AIRMOUNT<sup>®</sup>

ISOLATORS

Description		Assembly Order No.
Style 7002	Blind nut, 1/8 NPT	WO2-358-7002
Two Ply Bellows		
Assembly weight .....		1.8 lbs.

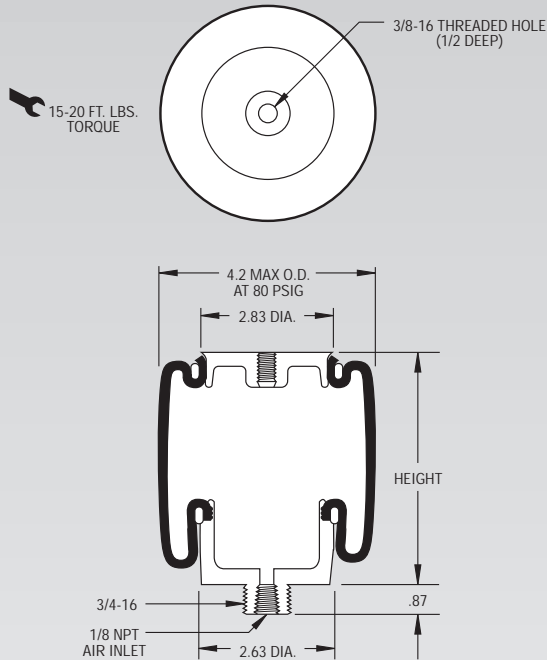

**NOTE: Bellows will not compress properly with less than 10 PSIG internal pressure.**

Dynamic Characteristics at 4.5 in. Design Height (Required for Airmount isolator design only)				
Volume @ 80 PSIG = 37 in <sup>3</sup>			Natural Frequency	
Gage Pressure (PSIG)	Load (lbs.)	Spring Rate (lbs./in.)	CPM	HZ
40	310	137	124	2.07
60	480	178	114	1.91
80	650	239	114	1.89
100	820	280	110	1.81

CONSULT FIRESTONE BEFORE USING AS AIRMOUNT

RECOMMENDED AIRMOUNT DESIGN HEIGHT 4.5 INCHES

**Static Data**  
8609

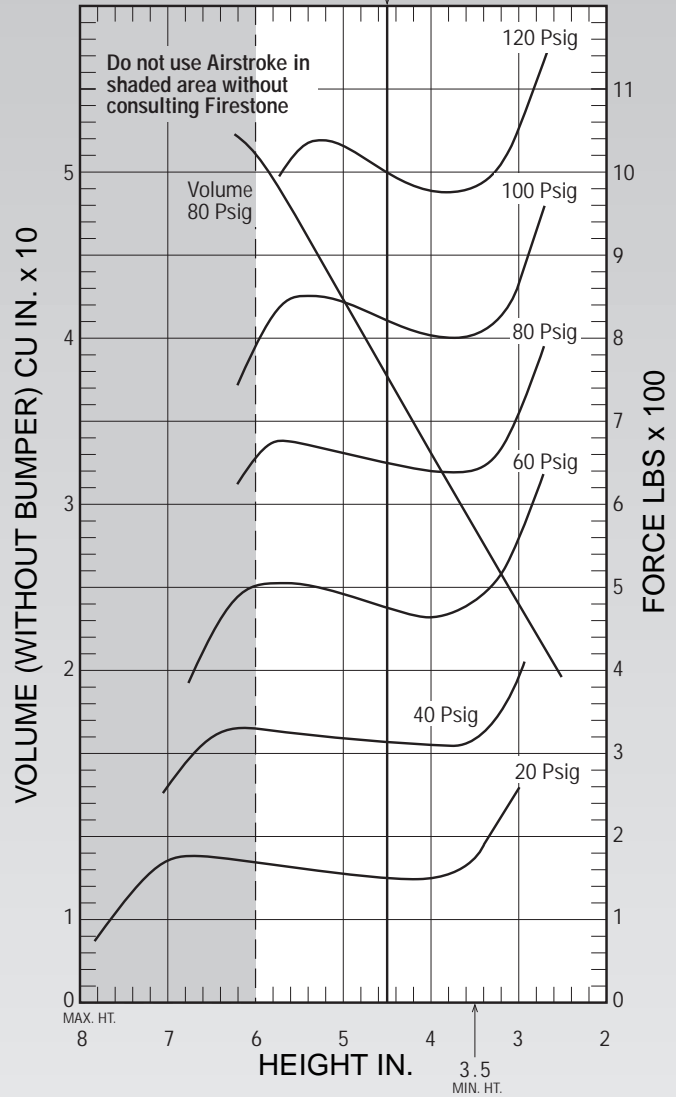

See page 12 for instructions on how to use chart.

Force Table (Use for Airstroke <sup>®</sup> actuator design)						
Assembly Height (in.)	Volume @ 80 PSIG (in <sup>3</sup> )	Pounds Force				
		@20 PSIG	@40 PSIG	@60 PSIG	@80 PSIG	@100 PSIG
6.0	50	170	330	510	680	860
5.0	42	150	320	490	660	840
4.0	33	150	310	470	640	800

Description		Assembly Order No.
Style 7010	Blind nut, 1/8 NPT	WO2-358-7010
Two Ply Bellows		
Assembly weight .....		1.6 lbs.

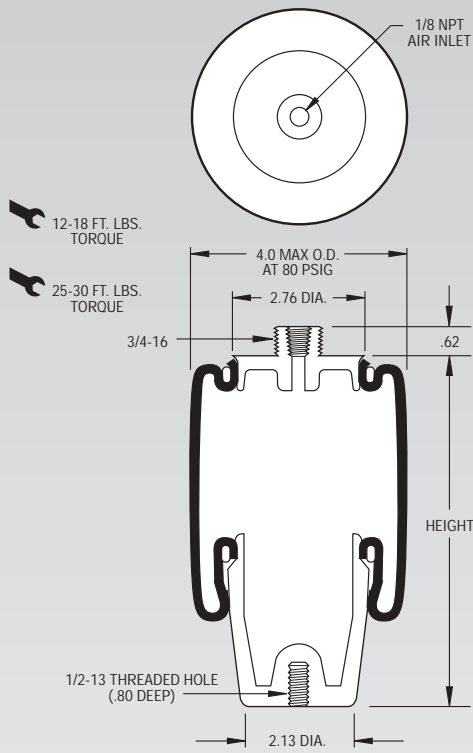

**NOTE:** Bellows will not compress properly with less than 10 PSIG internal pressure.

Dynamic Characteristics at 8.0 in. Design Height (Required for Airmount isolator design only)				
Volume @ 80 PSIG = 58 in <sup>3</sup>			Natural Frequency	
Gage Pressure (PSIG)	Load (lbs.)	Spring Rate (lbs./in.)	CPM	HZ
40	280	62	88	1.47
60	440	89	84	1.40
80	600	116	83	1.38
100	810	107	68	1.13

CONSULT FIRESTONE BEFORE USING AS AIRMOUNT

RECOMMENDED AIRMOUNT DESIGN HEIGHT 8.0 INCHES

**Static Data**  
8612

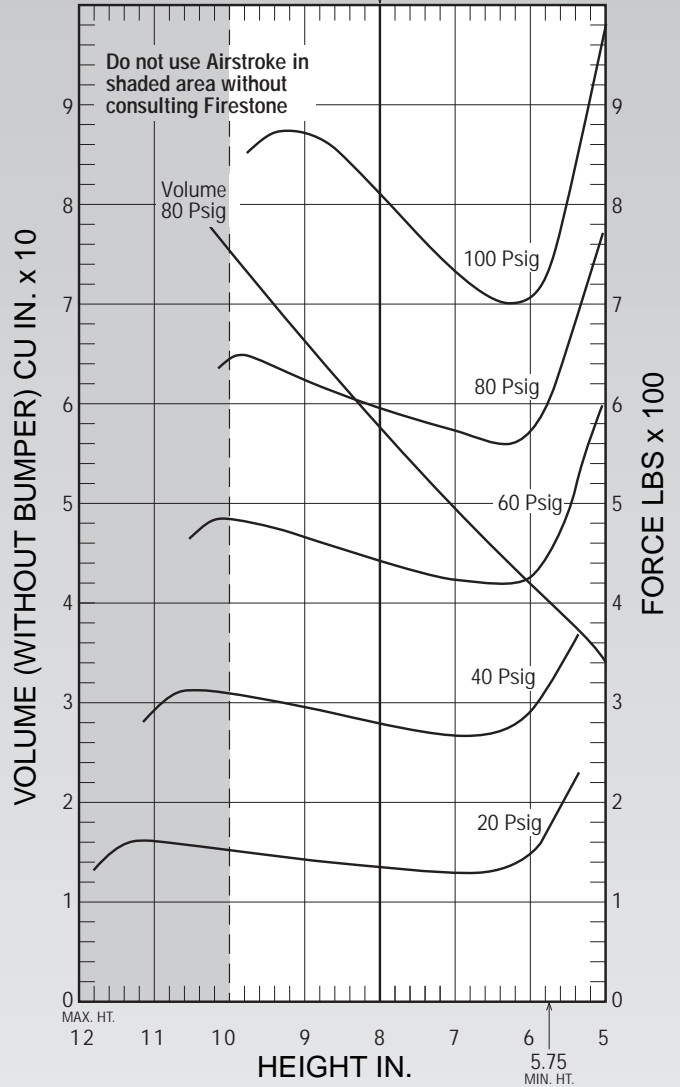

See page 12 for instructions on how to use chart.

Force Table (Use for Airstroke® actuator design)						
Assembly Height (in.)	Volume @ 80 PSIG (in <sup>3</sup> )	Pounds Force				
		@20 PSIG	@40 PSIG	@60 PSIG	@80 PSIG	@100 PSIG
10.0	75	150	310	480	650	880
9.0	67	140	300	470	630	870
8.0	58	140	280	440	600	810
7.0	50	130	270	430	580	740

# 7012

# Firestone

# AIRSTROKE<sup>®</sup>

ACTUATORS

# AIRMOUNT<sup>®</sup>

ISOLATORS

Description		Assembly Order No.
Style 7012	Blind nut, 1/8 NPT	WO2-358-7012
Two Ply Bellows		
Assembly weight .....		1.8 lbs.

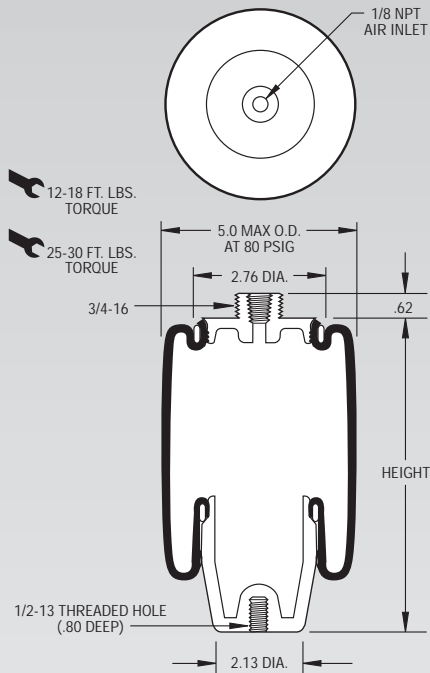

**NOTE:** Bellows will not compress properly with less than 10 PSIG internal pressure.

Dynamic Characteristics at 8.5 in. Design Height (Required for Airmount isolator design only)				
Volume @ 80 PSIG = 93 in <sup>3</sup>			Natural Frequency	
Gage Pressure (PSIG)	Load (lbs.)	Spring Rate (lbs./in.)	CPM	HZ
40	360	69	82	1.37
60	590	115	83	1.38
80	800	131	76	1.27
100	1,000	184	80	1.34

CONSULT FIRESTONE BEFORE USING AS AIRMOUNT

RECOMMENDED AIRMOUNT DESIGN HEIGHT 8.5 INCHES

**Static Data**  
8108

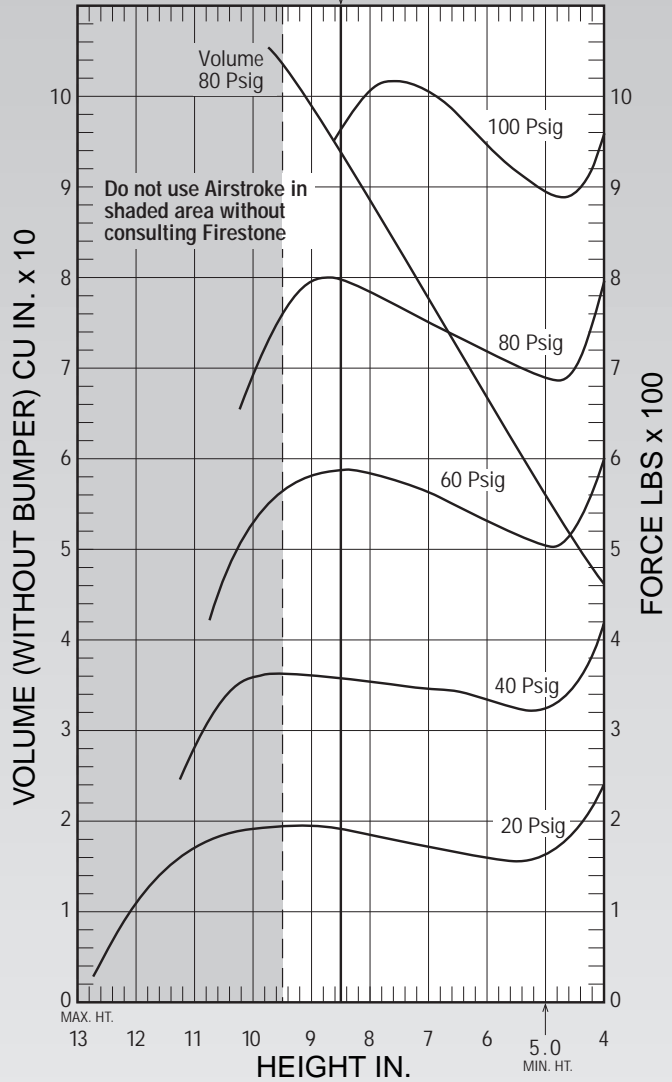

See page 12 for instructions on how to use chart.

Force Table (Use for Airstroke <sup>®</sup> actuator design)						
Assembly Height (in.)	Volume @ 80 PSIG (in <sup>3</sup> )	Pounds Force				
		@20 PSIG	@40 PSIG	@60 PSIG	@80 PSIG	@100 PSIG
9.0	98	200	370	590	800	1,020
8.0	87	190	360	590	780	1,020
7.0	76	170	350	560	750	1,000
6.0	66	160	340	530	720	950
5.0	56	170	330	510	690	890

Description		Assembly Order No.
Style 1T12E-3	Blind nuts, 1/4 NPT	WO1-358-8119
Two Ply Bellows	Socket head aluminum bead ring (bolts, nuts, washers not included, use cap screws)	WO1-358-8118
Assembly weight .....		3.5 lbs.

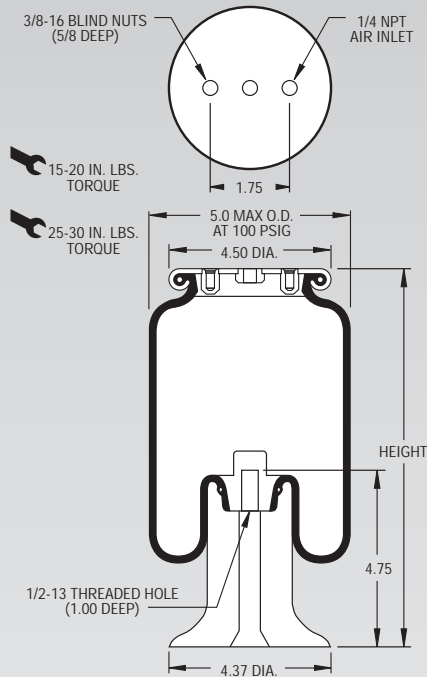

**NOTE:** Bellows will not compress properly with less than 10 PSIG internal pressure.

**NOTE:** A bead plate part is shown. This part is also available with a bead ring. Bolts are not included. See pages 8-10 for explanation.

Dynamic Characteristics at 10.5 in. Design Height (Required for Airmount isolator design only)				
Volume @ 100 PSIG = 89 in <sup>3</sup>			Natural Frequency	
Gage Pressure (PSIG)	Load (lbs.)	Spring Rate (lbs./in.)	CPM	HZ
40	290	53	81	1.35
60	450	75	77	1.28
80	600	91	73	1.22
100	770	114	72	1.21

CONSULT FIRESTONE BEFORE USING AS AIRMOUNT

RECOMMENDED AIRMOUNT DESIGN HEIGHT 10.5 INCHES

Static Data 9232

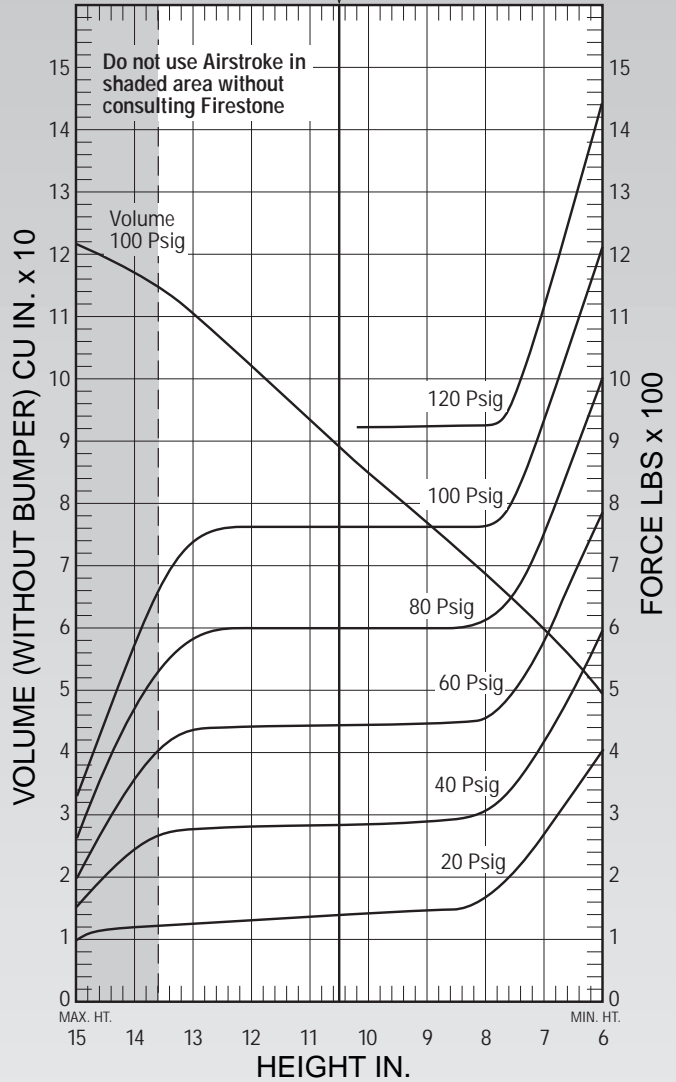

See page 12 for instructions on how to use chart.

Force Table (Use for Airstroke® actuator design)						
Assembly Height (in.)	Volume @ 100 PSIG (in <sup>3</sup> )	Pounds Force				
		@20 PSIG	@40 PSIG	@60 PSIG	@80 PSIG	@100 PSIG
13.0	110	130	280	440	580	740
12.0	102	130	280	450	600	760
11.0	94	140	280	450	600	760
10.0	85	150	290	450	600	770
9.0	77	150	290	450	600	770
8.0	69	170	310	460	610	760
7.0	60	270	420	580	750	920

# 1T14C-1 Firestone



Description		Assembly Order No.
Style 1T14C-1	Blind nuts, 1/4 NPT	WO1-358-5310
	Blind nuts, 1/4 NPT, bumper	WO1-358-5311
Two Ply Bellows	Blind nuts, 3/4 NPT	WO1-358-5305
	Blind nuts, 3/4 NPT, bumper	WO1-358-5306
	Countersunk steel bead ring 1 3/4 bolts, nuts, washers	WO1-358-5307
Assembly weight .....		6.5 lbs.

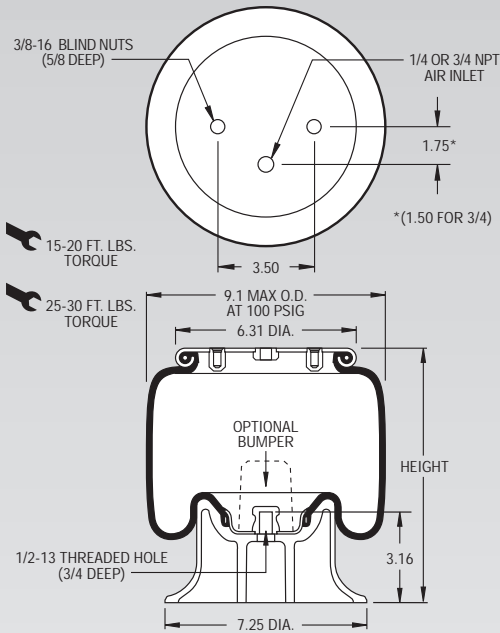

**NOTE:** Bellows will not compress properly with less than 10 PSIG internal pressure.

**NOTE:** A bead plate part is shown. This part is also available with a bead ring. Bolts are not included. See pages 8-10 for explanation.

Dynamic Characteristics at 10.0 in. Design Height (Required for Airmount isolator design only)				
Volume @ 100 PSIG = 314 in <sup>3</sup>			Natural Frequency	
Gage Pressure (PSIG)	Load (lbs.)	Spring Rate (lbs./in.)	CPM	HZ
40	1,210	250	85	1.42
60	1,880	398	86	1.44
80	2,540	535	86	1.43
100	3,220	658	85	1.41

CONSULT FIRESTONE BEFORE USING AS AIRMOUNT

RECOMMENDED AIRMOUNT DESIGN HEIGHT 10.0 INCHES

Static Data  
3019

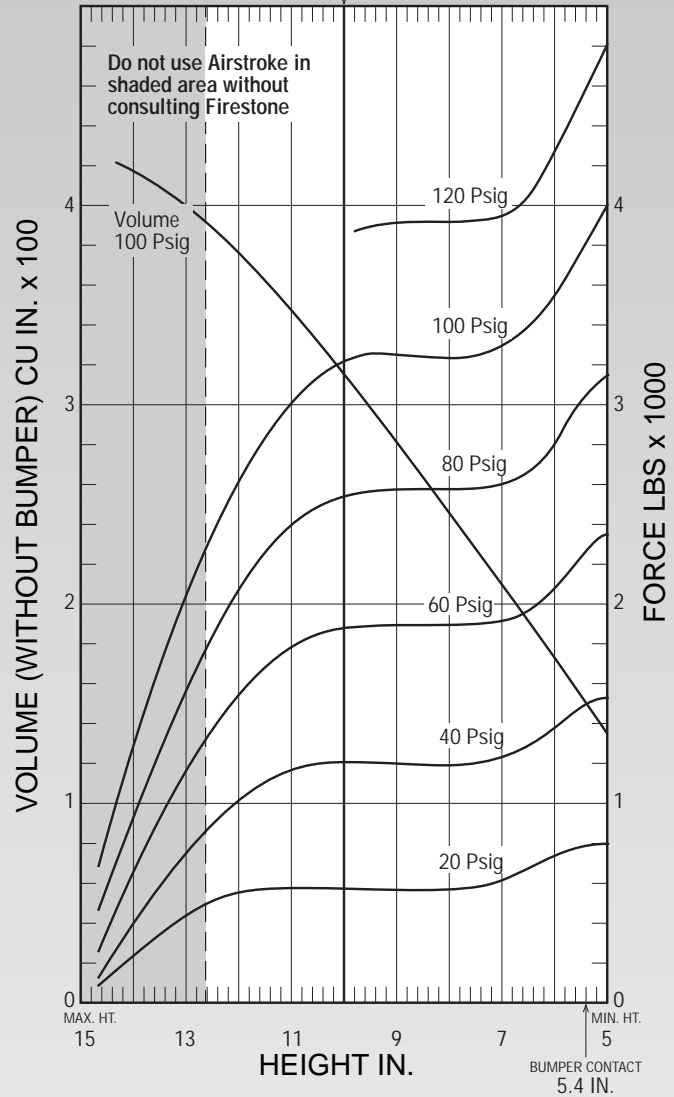

See page 12 for instructions on how to use chart.

Force Table (Use for Airstroke® actuator design)						
Assembly Height (in.)	Volume @ 100 PSIG (in <sup>3</sup> )	Pounds Force				
		@20 PSIG	@40 PSIG	@60 PSIG	@80 PSIG	@100 PSIG
12.0	376	540	1,010	1,530	2,040	2,600
11.0	347	570	1,160	1,770	2,380	3,010
10.0	314	590	1,210	1,880	2,540	3,220
9.0	280	590	1,190	1,890	2,570	3,240
8.0	246	580	1,200	1,890	2,570	3,240
7.0	211	620	1,240	1,920	2,600	3,300
6.0	176	740	1,380	2,060	2,790	3,530

Description		Assembly Order No.
Style 1T14C-3	Blind nuts, 1/4 NPT	WO1-358-5405
Two Ply Bellows		
Assembly weight .....		6.8 lbs.

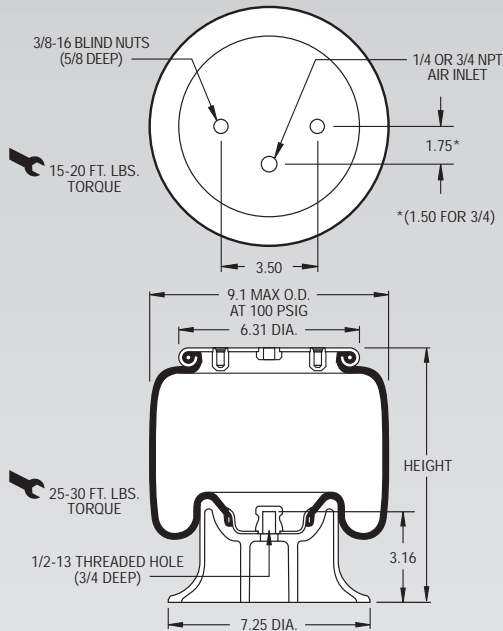

**NOTE: Bellows will not compress properly with less than 10 PSIG internal pressure.**

**NOTE: A bead plate part is shown. This part is also available with a bead ring. Bolts are not included. See pages 8-10 for explanation.**

Dynamic Characteristics at 11.0 in. Design Height (Required for Airmount isolator design only)				
Volume @ 100 PSIG = 366 in <sup>3</sup>			Natural Frequency	
Gage Pressure (PSIG)	Load (lbs.)	Spring Rate (lbs./in.)	CPM	HZ
40	1,230	214	78	1.31
60	1,890	333	79	1.31
80	2,570	424	76	1.27
100	3,240	520	75	1.25

CONSULT FIRESTONE BEFORE USING AS AIRMOUNT

RECOMMENDED AIRMOUNT DESIGN HEIGHT 11.0 INCHES

**Static Data**  
3018

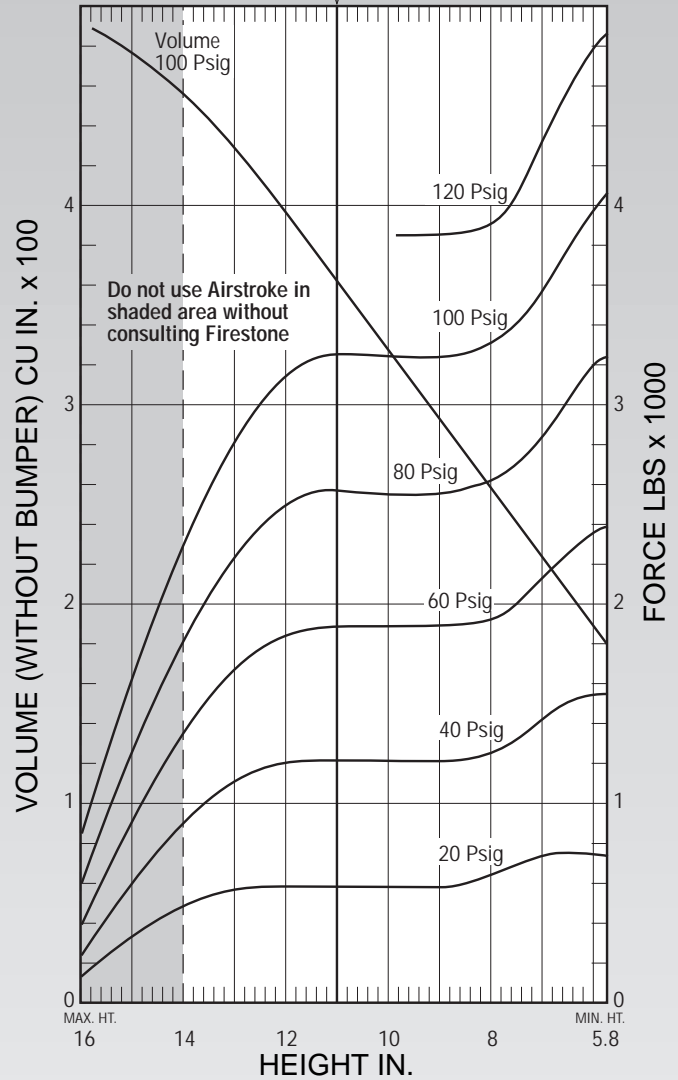

See page 12 for instructions on how to use chart.

Force Table (Use for Airstroke® actuator design)						
Assembly Height (in.)	Volume @ 100 PSIG (in <sup>3</sup> )	Pounds Force				
		@20 PSIG	@40 PSIG	@60 PSIG	@80 PSIG	@100 PSIG
14.0	456	490	890	1,330	1,780	2,240
12.0	399	590	1,210	1,840	2,470	3,130
10.0	331	590	1,220	1,900	2,560	3,240
8.0	263	650	1,260	1,940	2,630	3,310
6.0	189	760	1,570	2,370	3,200	4,010

# 1T14C-7 Firestone



Description		Assembly Order No.
Style 1T14C-7	Blind nuts, 1/4 NPT	WO1-358-5712
Two Ply Bellows	Blind nuts, 3/4 NPT	WO1-358-5708
Assembly weight .....		7.0 lbs.
Style 1T28C-7	Blind nuts, 1/4 NPT	WO1-358-5743
High Strength Bellows		

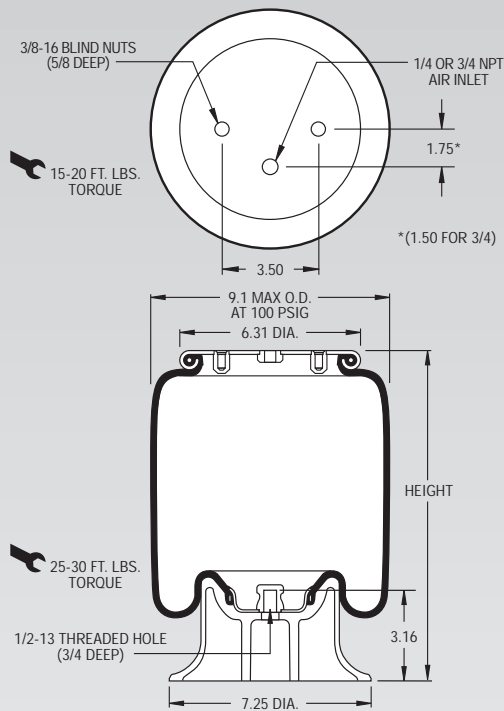

**NOTE:** Bellows will not compress properly with less than 10 PSIG internal pressure.

**NOTE:** A bead plate part is shown. This part is also available with a bead ring. Bolts are not included. See pages 8-10 for explanation.

Dynamic Characteristics at 13.5 in. Design Height (Required for Airmount isolator design only)				
Volume @ 100 PSIG = 507 in <sup>3</sup>			Natural Frequency	
Gage Pressure (PSIG)	Load (lbs.)	Spring Rate (lbs./in.)	CPM	HZ
40	1,250	166	68	1.14
60	1,910	243	67	1.12
80	2,600	305	64	1.07
100	3,240	397	66	1.10

CONSULT FIRESTONE BEFORE USING AS AIRMOUNT

RECOMMENDED AIRMOUNT DESIGN HEIGHT 13.5 INCHES

Static Data 3045

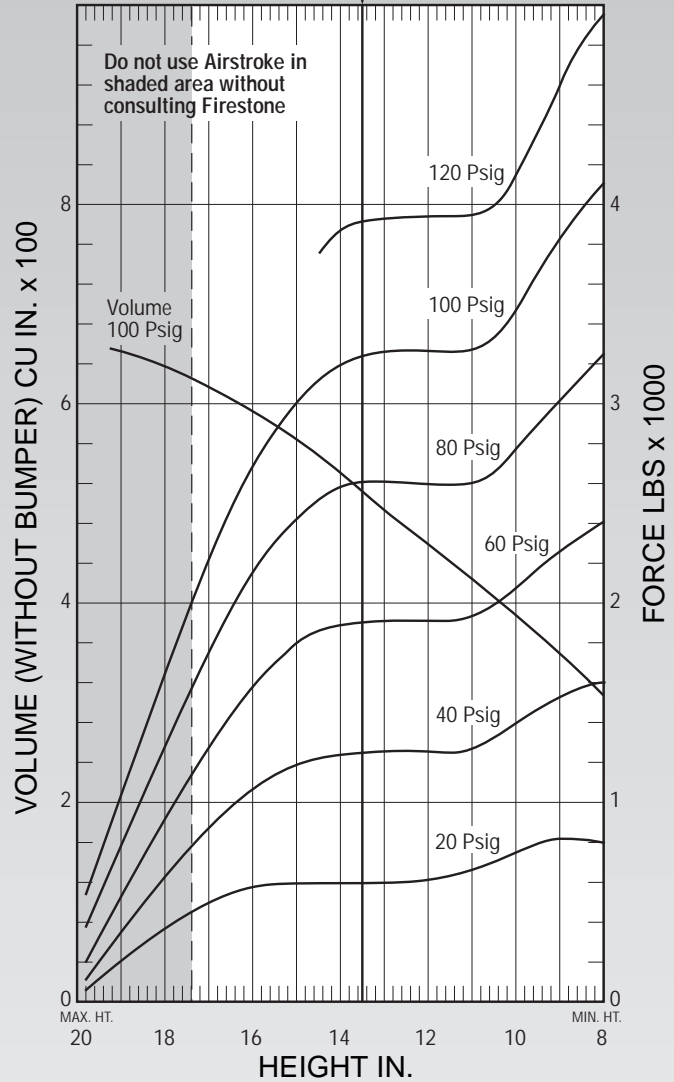

See page 12 for instructions on how to use chart.

Force Table (Use for Airstroke® actuator design)						
Assembly Height (in.)	Volume @ 100 PSIG (in <sup>3</sup> )	Pounds Force				
		@20 PSIG	@40 PSIG	@60 PSIG	@80 PSIG	@100 PSIG
17.0	615	500	890	1,310	1,790	2,260
15.0	558	600	1,210	1,820	2,460	3,070
13.0	490	600	1,250	1,920	2,610	3,260
11.0	421	660	1,280	1,930	2,610	3,270
9.0	349	820	1,540	2,270	3,040	3,850



Description		Assembly Order No.
Style 1T15T-1	Blind nuts, 1/4 NPT	WO1-358-9400
	Blind nuts, 1/4 NPT, bumper	WO1-358-9402
Two Ply Bellows	Blind nuts, 3/4 NPT	WO1-358-9401
Assembly weight .....		10.4 lbs.

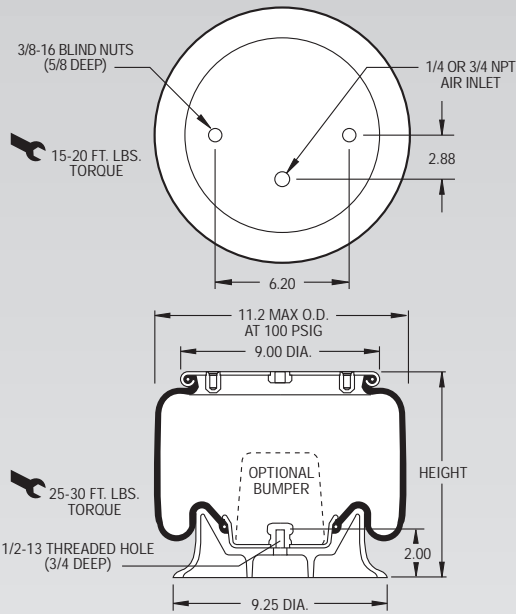

**NOTE:** Bellows will not compress properly with less than 10 PSIG internal pressure.

**NOTE:** A bead plate part is shown. This part is also available with a bead ring. Bolts are not included. See pages 8-10 for explanation..

Dynamic Characteristics at 7.0 in. Design Height (Required for Airmount isolator design only)				
Volume @ 100 PSIG = 373 in <sup>3</sup>			Natural Frequency	
Gage Pressure (PSIG)	Load (lbs.)	Spring Rate (lbs./in.)	CPM	HZ
40	2,100	658	105	1.75
60	3,220	908	100	1.66
80	4,370	1,168	97	1.62
100	5,490	1,408	95	1.58

CONSULT FIRESTONE BEFORE USING AS AIRMOUNT

RECOMMENDED AIRMOUNT DESIGN HEIGHT 7.0 INCHES

**Static Data**  
4209

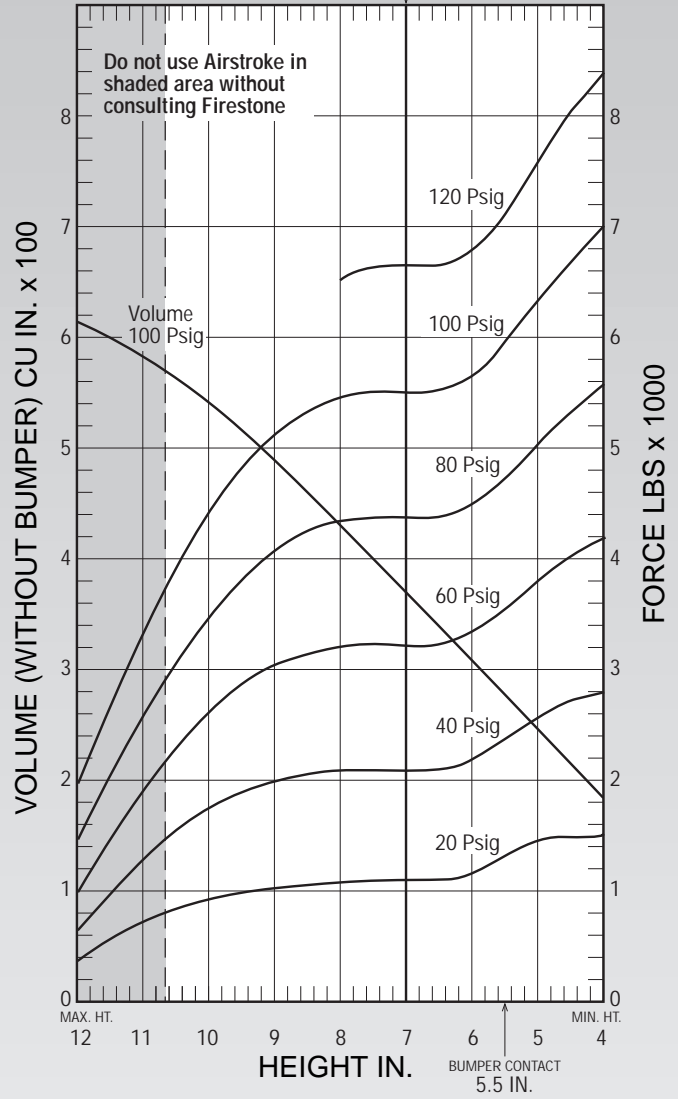

See page 12 for instructions on how to use chart.

Force Table (Use for Airstroke® actuator design)						
Assembly Height (in.)	Volume @ 100 PSIG (in <sup>3</sup> )	Pounds Force				
		@20 PSIG	@40 PSIG	@60 PSIG	@80 PSIG	@100 PSIG
10.0	541	920	1,750	2,600	3,470	4,410
9.0	490	1,030	2,010	3,050	4,050	5,130
8.0	433	1,100	2,090	3,210	4,330	5,470
7.0	373	1,110	2,100	3,220	4,370	5,490
6.0	314	1,160	2,190	3,330	4,480	5,650
5.0	251	1,450	2,570	3,780	5,010	6,290

# 1T15S-6 Firestone



Description		Assembly Order No.
Style 1T15S-6	Blind nuts, 1/4 NPT	WO1-358-9048
	Blind nuts, 1/4 NPT, bumper	WO1-358-9049
Two Ply Bellows	Blind nuts, 3/4 NPT	WO1-358-9051
Assembly weight .....		13.7 lbs.

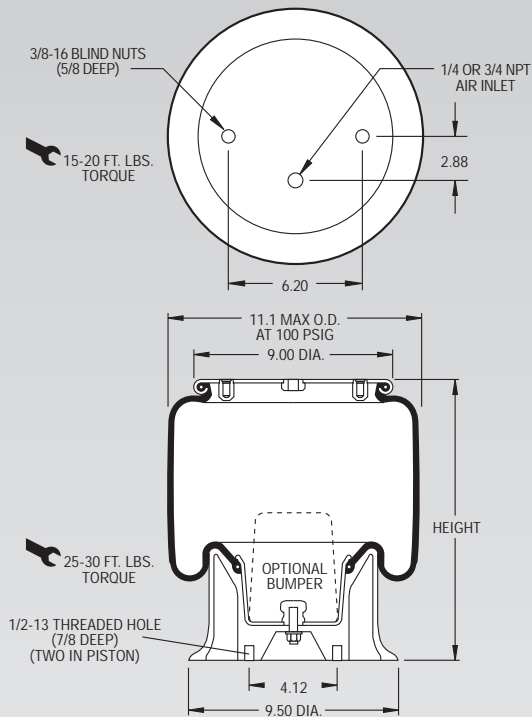

**NOTE:** Bellows will not compress properly with less than 20 PSIG internal pressure.

**NOTE:** A bead plate part is shown. This part is also available with a bead ring. Bolts are not included. See pages 8-10 for explanation.

Dynamic Characteristics at 12.0 in. Design Height (Required for Airmount isolator design only)				
Volume @ 100 PSIG = 625 in <sup>3</sup>			Natural Frequency	
Gage Pressure (PSIG)	Load (lbs.)	Spring Rate (lbs./in.)	CPM	HZ
40	2,040	363	79	1.32
60	3,140	513	76	1.26
80	4,220	657	74	1.23
100	5,340	813	73	1.22

CONSULT FIRESTONE BEFORE USING AS AIRMOUNT

RECOMMENDED AIRMOUNT DESIGN HEIGHT 12.0 INCHES

Static Data 7597

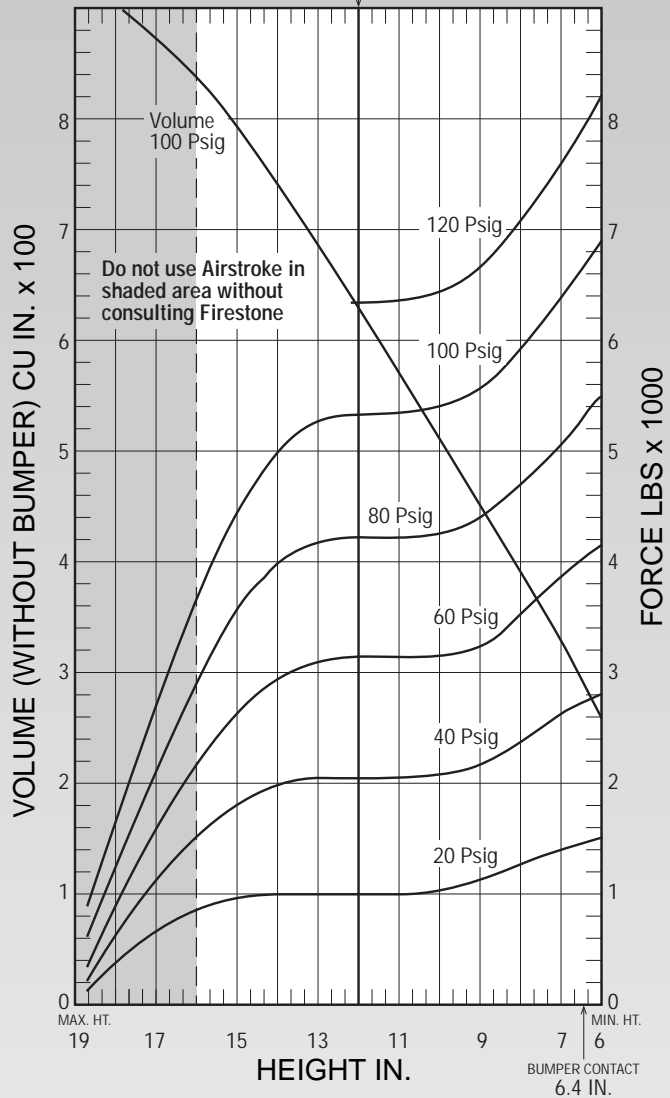

See page 12 for instructions on how to use chart.

Force Table (Use for Airstroke® actuator design)						
Assembly Height (in.)	Volume @ 100 PSIG (in <sup>3</sup> )	Pounds Force				
		@20 PSIG	@40 PSIG	@60 PSIG	@80 PSIG	@100 PSIG
16.0	834	830	1,580	2,140	2,860	3,600
14.0	739	1,010	1,980	2,930	3,980	5,000
12.0	625	980	2,040	3,140	4,220	5,340
10.0	509	1,030	2,100	3,160	4,270	5,410
8.0	392	1,280	2,380	3,520	4,690	5,930

Description		Assembly Order No.
Style 1T15L-4	Blind nuts, 1/4 NPT	WO1-358-9414
Two Ply Bellows		
Assembly weight .....		15.5 lbs.

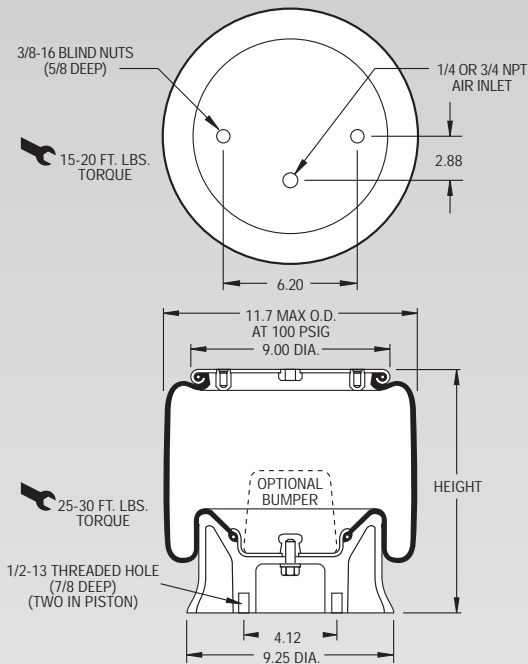

**NOTE:** Bellows will not compress properly with less than 10 PSIG internal pressure.

**NOTE:** A bead plate part is shown. This part is also available with a bead ring. Bolts are not included. See pages 8-10 for explanation.

Dynamic Characteristics at 11.0 in. Design Height (Required for Airmount isolator design only)				
Volume @ 100 PSIG = 625 in <sup>3</sup>			Natural Frequency	
Gage Pressure (PSIG)	Load (lbs.)	Spring Rate (lbs./in.)	CPM	HZ
40	2,650	583	88	1.47
60	4,080	823	84	1.40
80	5,510	1,055	82	1.37
100	6,930	1,281	81	1.34

CONSULT FIRESTONE BEFORE USING AS AIRMOUNT

RECOMMENDED AIRMOUNT DESIGN HEIGHT 11.0 INCHES

**Static Data**  
3105

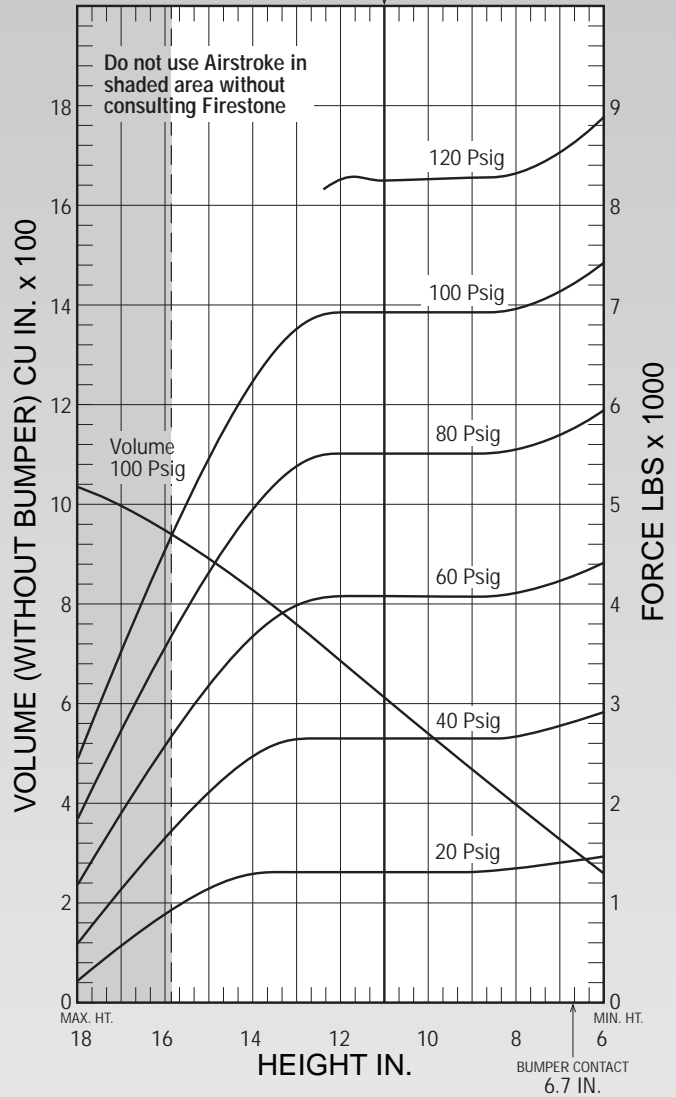

See page 12 for instructions on how to use chart.

Force Table (Use for Airstroke® actuator design)						
Assembly Height (in.)	Volume @ 100 PSIG (in <sup>3</sup> )	Pounds Force				
		@20 PSIG	@40 PSIG	@60 PSIG	@80 PSIG	@100 PSIG
15.0	898	1,120	2,110	3,150	4,300	5,440
13.0	768	1,310	2,630	3,970	5,360	6,720
11.0	625	1,310	2,650	4,080	5,510	6,930
9.0	479	1,310	2,650	4,080	5,500	6,920
7.0	333	1,390	2,780	4,210	5,690	7,120

# 1T15M-0 Firestone



Description		Assembly Order No.
Style 1T15M-0	Blind nuts, 1/4 NPT	WO1-358-9030
Two Ply Bellows	Blind nuts, 1/4 NPT, rubber bumper	WO1-358-9031
	Blind nuts, 3/4 NPT	WO1-358-9034
	Blind nuts, 3/4 NPT, rubber bumper	WO1-358-9036
	Countersunk steel bead ring, 1 3/8 bolts, nuts, washers	WO1-358-9038
	Integral studs, 1/4 NPT	WO1-358-9035
Assembly weight .....		11.5 lbs.

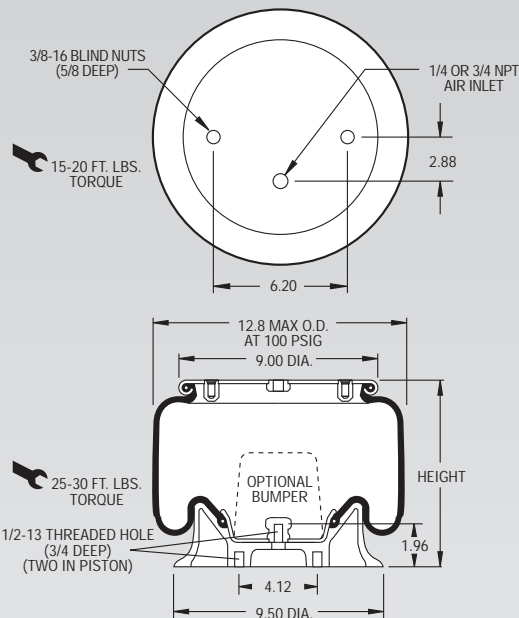

**NOTE:** Bellows will not compress properly with less than 10 PSIG internal pressure.

**NOTE:** A bead plate part is shown. This part is also available with a bead ring. Bolts are not included. See pages 8-10 for explanation.

Dynamic Characteristics at 7.5 in. Design Height (Required for Airmount isolator design only)				
Volume @ 100 PSIG = 498 in <sup>3</sup>			Natural Frequency	
Gage Pressure (PSIG)	Load (lbs.)	Spring Rate (lbs./in.)	CPM	HZ
40	2,670	793	102	1.71
60	4,120	1,105	97	1.62
80	5,540	1,399	94	1.57
100	6,990	1,690	92	1.54

CONSULT FIRESTONE BEFORE USING AS AIRMOUNT

RECOMMENDED AIRMOUNT DESIGN HEIGHT 7.5 INCHES

Static Data 8826

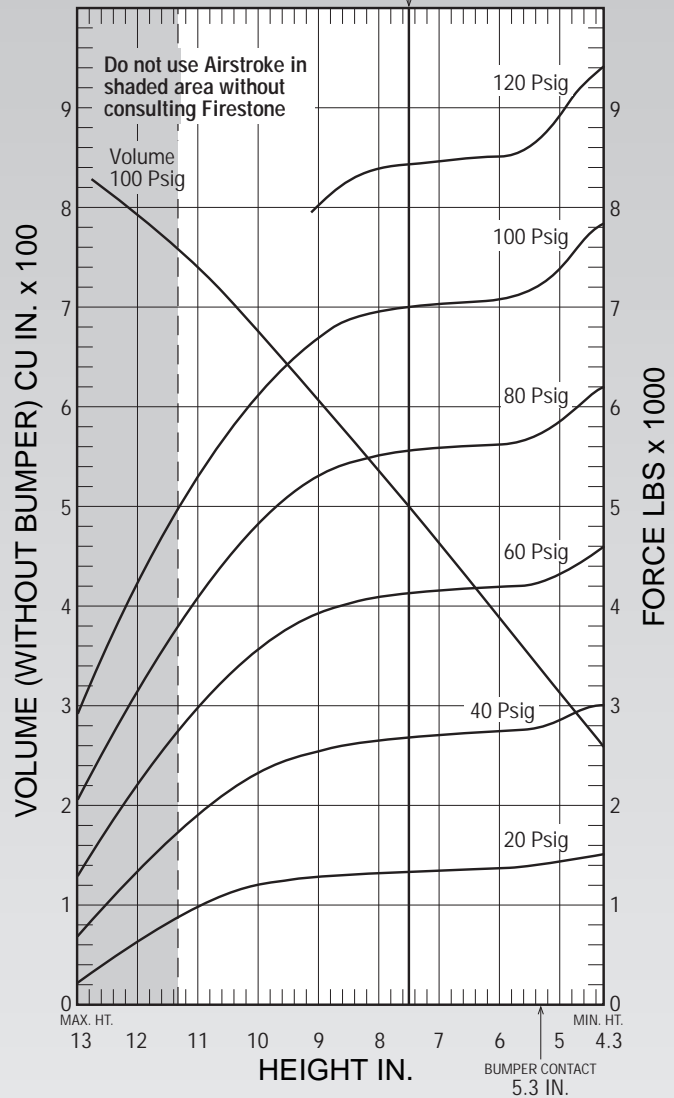

See page 12 for instructions on how to use chart.

Force Table (Use for Airstroke® actuator design)						
Assembly Height (in.)	Volume @ 100 PSIG (in <sup>3</sup> )	Pounds Force				
		@20 PSIG	@40 PSIG	@60 PSIG	@80 PSIG	@100 PSIG
11.0	737	980	1,920	2,980	4,120	5,300
10.0	675	1,180	2,310	3,550	4,810	6,130
9.0	606	1,270	2,540	3,910	5,290	6,710
8.0	534	1,300	2,630	4,080	5,500	6,950
7.0	462	1,320	2,690	4,140	5,570	7,010
6.0	389	1,350	2,730	4,170	5,610	7,070
5.0	314	1,410	2,840	4,310	5,840	7,370

Description		Assembly Order No.
Style 1T15M-2	Blind nuts, 1/4 NPT	WO1-358-9042
	Blind nuts, 1/4 NPT, bumper	WO1-358-9053
Two Ply Bellows	Blind nuts, 3/4 NPT	WO1-358-9054
	Blind nuts, 3/4 NPT, bumper	WO1-358-9099
Assembly weight .....		13.2 lbs.

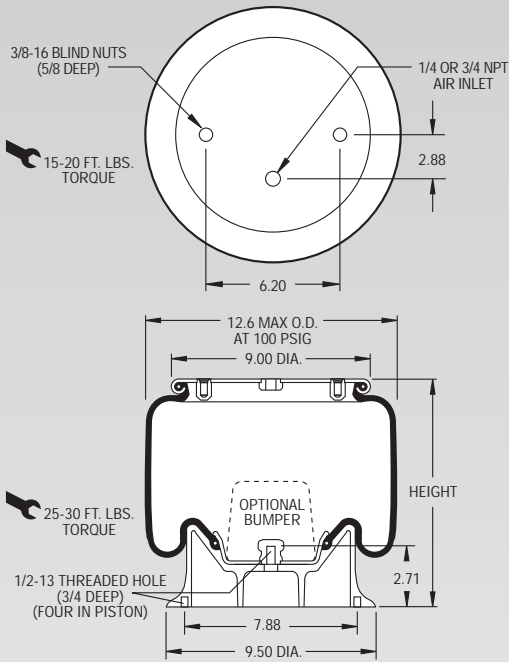

**NOTE:** Bellows will not compress properly with less than 10 PSIG internal pressure.

**NOTE:** A bead plate part is shown. This part is also available with a bead ring. Bolts are not included. See pages 8-10 for explanation.

Dynamic Characteristics at 9.5 in. Design Height (Required for Airmount isolator design only)				
Volume @ 100 PSIG = 648 in <sup>3</sup>			Natural Frequency	
Gage Pressure (PSIG)	Load (lbs.)	Spring Rate (lbs./in.)	CPM	HZ
40	2,850	693	93	1.54
60	4,370	965	88	1.47
80	5,900	1,238	86	1.43
100	7,510	1,510	84	1.40

CONSULT FIRESTONE BEFORE USING AS AIRMOUNT

RECOMMENDED AIRMOUNT DESIGN HEIGHT 9.5 INCHES

**Static Data**  
A9109

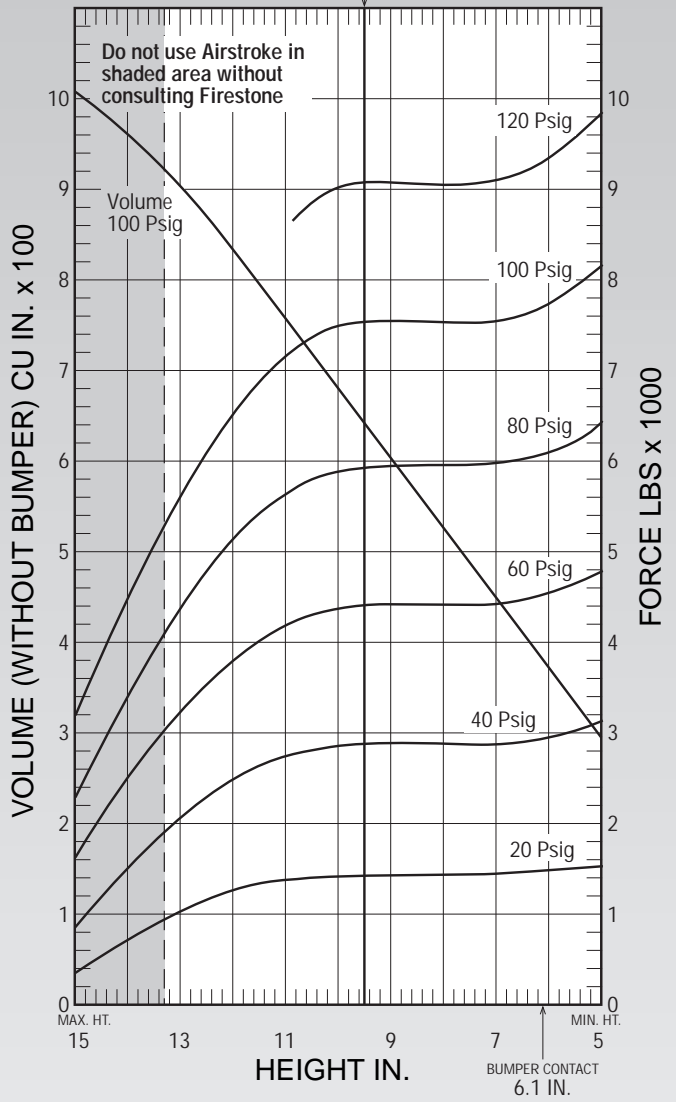

See page 12 for instructions on how to use chart.

Force Table (Use for Airstroke® actuator design)						
Assembly Height (in.)	Volume @ 100 PSIG (in <sup>3</sup> )	Pounds Force				
		@20 PSIG	@40 PSIG	@60 PSIG	@80 PSIG	@100 PSIG
13.0	900	1,000	2,030	3,170	4,320	5,580
12.0	835	1,210	2,420	3,720	5,040	6,440
11.0	763	1,330	2,680	4,120	5,570	7,100
10.0	687	1,380	2,820	4,330	5,850	7,460
9.0	609	1,400	2,860	4,390	5,920	7,530
8.0	531	1,400	2,850	4,390	5,930	7,510
7.0	453	1,410	2,860	4,410	5,950	7,530
6.0	374	1,440	2,930	4,530	6,080	7,730

# 1T15M-4 Firestone



Description		Assembly Order No.
Style 1T15M-4	Blind nuts, 1/4 NPT	WO1-358-9056
	Blind nuts, 1/4 NPT, bumper	WO1-358-9057
Two Ply Bellows	Blind nuts, 3/4 NPT	WO1-358-9062
	Blind nuts, 3/4 NPT, bumper	WO1-358-9060
Assembly weight .....		14.3 lbs

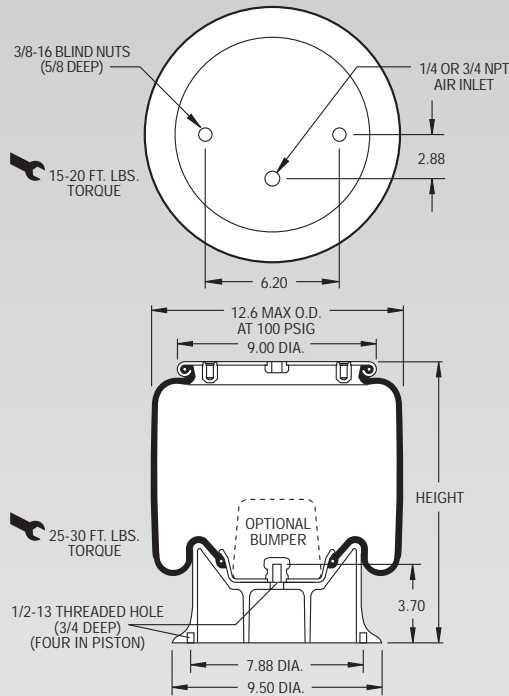

**NOTE:** Bellows will not compress properly with less than 10 PSIG internal pressure.

**NOTE:** A bead plate part is shown. This part is also available with a bead ring. Bolts are not included. See pages 8-10 for explanation.

Dynamic Characteristics at 12.5 in. Design Height (Required for Airmount isolator design only)				
Volume @ 100 PSIG = 898 in <sup>3</sup>			Natural Frequency	
Gage Pressure (PSIG)	Load (lbs.)	Spring Rate (lbs./in.)	CPM	HZ
40	2,760	459	77	1.28
60	4,200	620	72	1.20
80	5,670	803	71	1.18
100	7,170	986	70	1.16

CONSULT FIRESTONE BEFORE USING AS AIRMOUNT

RECOMMENDED AIRMOUNT DESIGN HEIGHT 12.5 INCHES

Static Data 3068

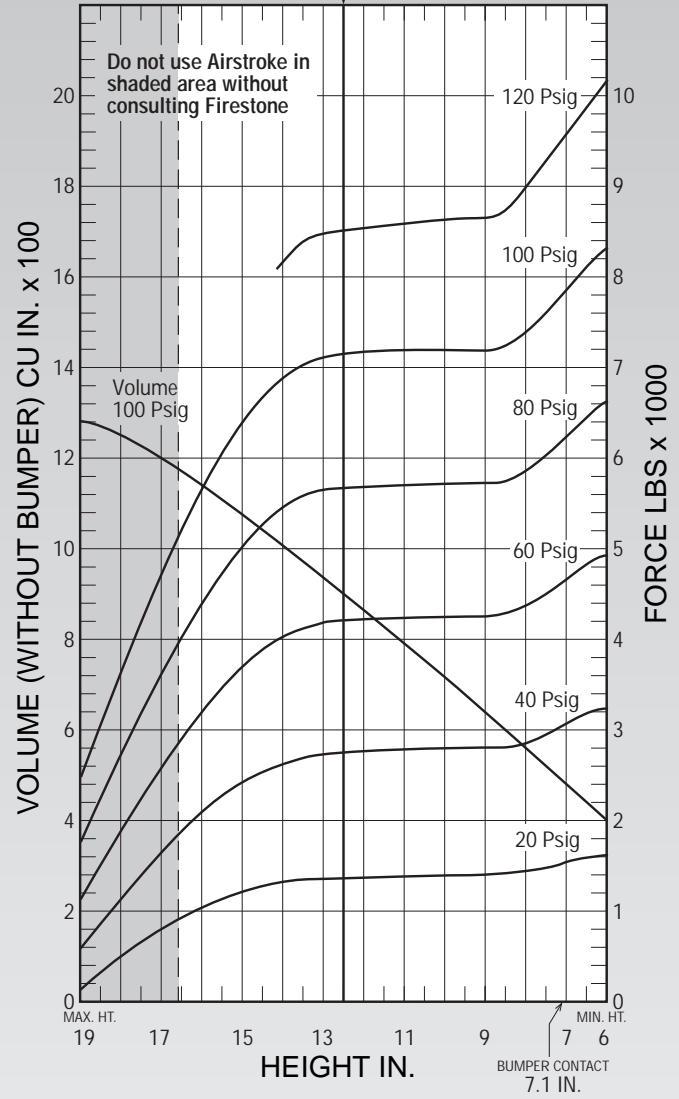

See page 12 for instructions on how to use chart.

Force Table (Use for Airstroke® actuator design)						
Assembly Height (in.)	Volume @ 100 PSIG (in <sup>3</sup> )	Pounds Force				
		@20 PSIG	@40 PSIG	@60 PSIG	@80 PSIG	@100 PSIG
16.0	1,146	1,060	2,110	3,240	4,410	5,680
14.0	1,010	1,330	2,650	4,050	5,460	6,910
12.0	861	1,380	2,770	4,210	5,690	7,190
10.0	711	1,390	2,790	4,230	5,720	7,190
8.0	561	1,440	2,880	4,370	5,860	7,400

Description		Assembly Order No.
Style 1T15M-6	Blind nuts, 1/4 NPT	WO1-358-9079
	Blind nuts, 1/4 NPT, bumper	WO1-358-9096
Two Ply Bellows	Blind nuts, 3/4 NPT	WO1-358-9089
	Blind nuts, 3/4 NPT, bumper	WO1-358-9088
	Blind nuts, 3/4 NPT (piston not included)	WO1-358-0730
Assembly weight (bead plate version, no bumper) ..... 15.7 lbs.		

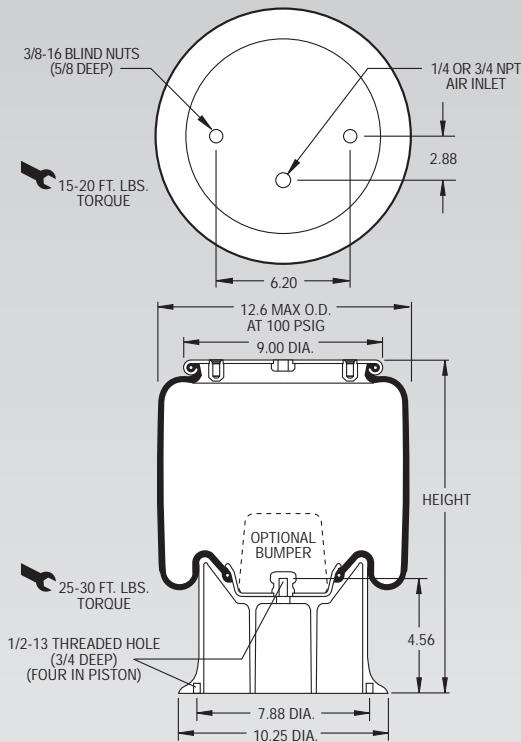

**NOTE:** Bellows will not compress properly with less than 10 PSIG internal pressure.

**NOTE:** A bead plate part is shown. This part is also available with a bead ring. Bolts are not included. See pages 8-10 for explanation.

Dynamic Characteristics at 15.0 in. Design Height (Required for Airmount isolator design only)				
Volume @ 100 PSIG = 1,060 in <sup>3</sup>			Natural Frequency	
Gage Pressure (PSIG)	Load (lbs.)	Spring Rate (lbs./in.)	CPM	HZ
40	2,720	395	71	1.19
60	4,110	541	68	1.13
80	5,560	707	67	1.12
100	7,000	852	65	1.09

CONSULT FIRESTONE BEFORE USING AS AIRMOUNT

RECOMMENDED AIRMOUNT DESIGN HEIGHT 15.0 INCHES

Static Data  
4452

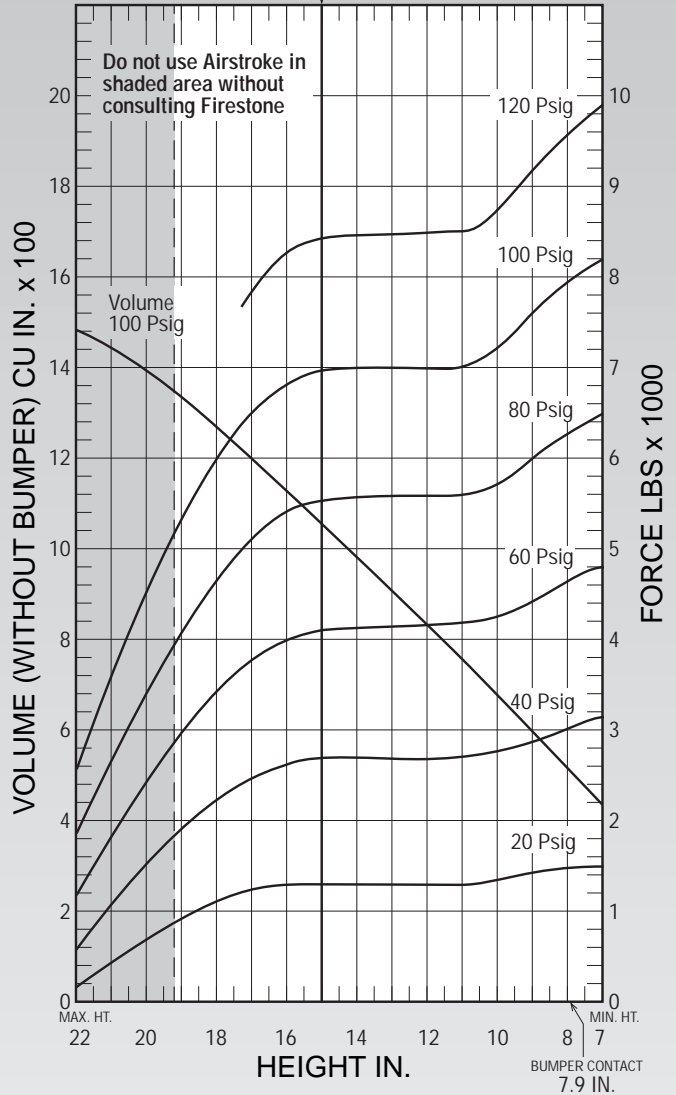

See page 12 for instructions on how to use chart.

Force Table (Use for Airstroke® actuator design)						
Assembly Height (in.)	Volume @ 100 PSIG (in <sup>3</sup> )	Pounds Force				
		@20 PSIG	@40 PSIG	@60 PSIG	@80 PSIG	@100 PSIG
18.0	1,274	1,100	2,220	3,420	4,670	5,980
16.0	1,134	1,290	2,640	4,000	5,410	6,840
14.0	987	1,330	2,730	4,130	5,590	7,030
12.0	841	1,330	2,710	4,170	5,590	7,010
10.0	693	1,380	2,790	4,270	5,730	7,240
8.0	533	1,500	3,060	4,670	6,280	7,950

# 1T15M-9 Firestone



Description		Assembly Order No.
Style 1T15M-9	Blind nuts, 1/4 NPT	WO1-358-9108
	Blind nuts, 1/4 NPT, bumper	WO1-358-9104
Two Ply Bellows	Blind nuts, 3/4 NPT	WO1-358-9106
	Blind nuts, 3/4 NPT, bumper	WO1-358-9117
Assembly weight .....		18.0 lbs.

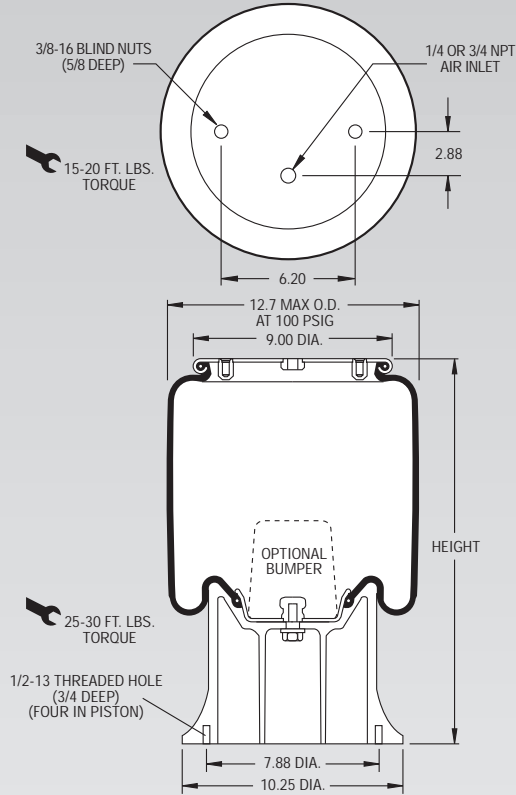

**NOTE:** Bellows will not compress properly with less than 10 PSIG internal pressure.

**NOTE:** A bead plate part is shown. This part is also available with a bead ring. Bolts are not included. See pages 8-10 for explanation.

Dynamic Characteristics at 18.5 in. Design Height (Required for Airmount isolator design only)				
Volume @ 100 PSIG = 1,330 in <sup>3</sup>			Natural Frequency	
Gage Pressure (PSIG)	Load (lbs.)	Spring Rate (lbs./in.)	CPM	HZ
40	2,780	287	60	1.01
60	4,250	425	59	.99
80	5,680	546	58	.97
100	7,120	659	57	.95

CONSULT FIRESTONE BEFORE USING AS AIRMOUNT

RECOMMENDED AIRMOUNT DESIGN HEIGHT 18.5 INCHES

Static Data  
3797

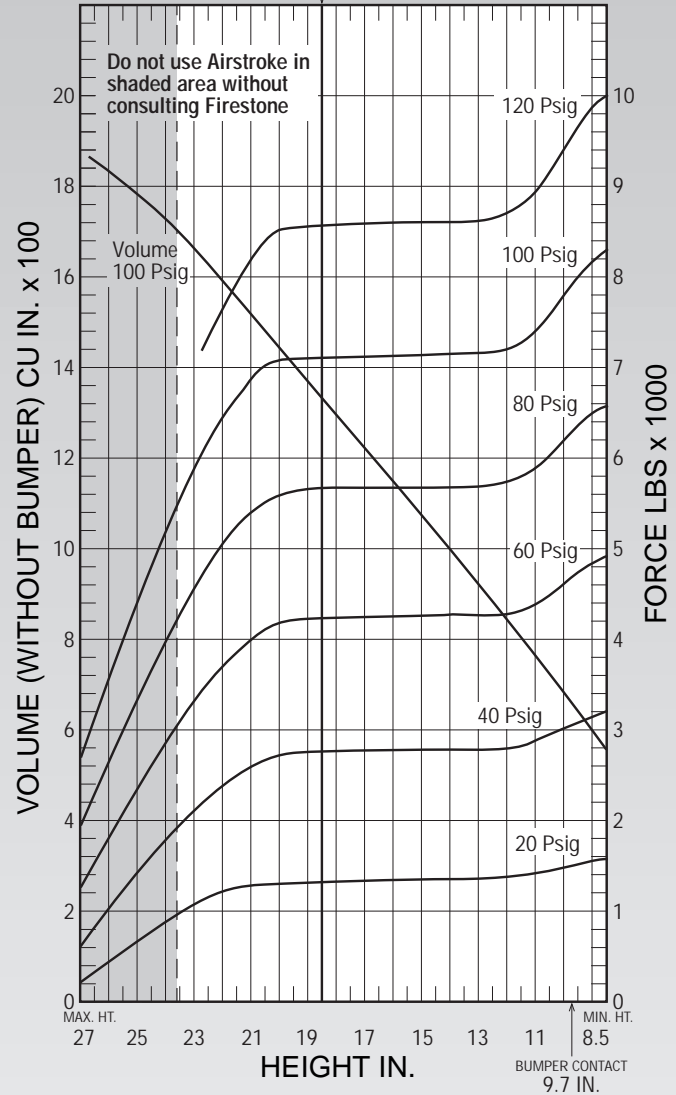

See page 12 for instructions on how to use chart.

Force Table (Use for Airstroke® actuator design)						
Assembly Height (in.)	Volume @ 100 PSIG (in <sup>3</sup> )	Pounds Force				
		@20 PSIG	@40 PSIG	@60 PSIG	@80 PSIG	@100 PSIG
23.0	1,658	1,090	2,150	3,340	4,560	5,850
21.0	1,517	1,290	2,600	4,020	5,380	6,860
19.0	1,368	1,340	2,780	4,240	5,660	7,110
17.0	1,217	1,370	2,770	4,250	5,680	7,140
15.0	1,067	1,380	2,810	4,290	5,690	7,150
13.0	916	1,390	2,810	4,280	5,700	7,170
11.0	760	1,460	2,950	4,430	5,940	7,500
9.0	596	1,580	3,200	4,880	6,550	8,230



Description		Assembly Order No.
Style 1T19L-7	Blind nuts, 1/4 NPT	WO1-358-9148
	Blind nuts, 1/4 NPT, bumper	WO1-358-9149
Two Ply Bellows	Blind nuts, 3/4 NPT	WO1-358-9172
	Blind nuts, 3/4 NPT, bumper	WO1-358-9160
	Button head steel bead ring 1 7/8 bolts, nuts, washers	WO1-358-9165
Assembly weight .....		24.60 lbs.

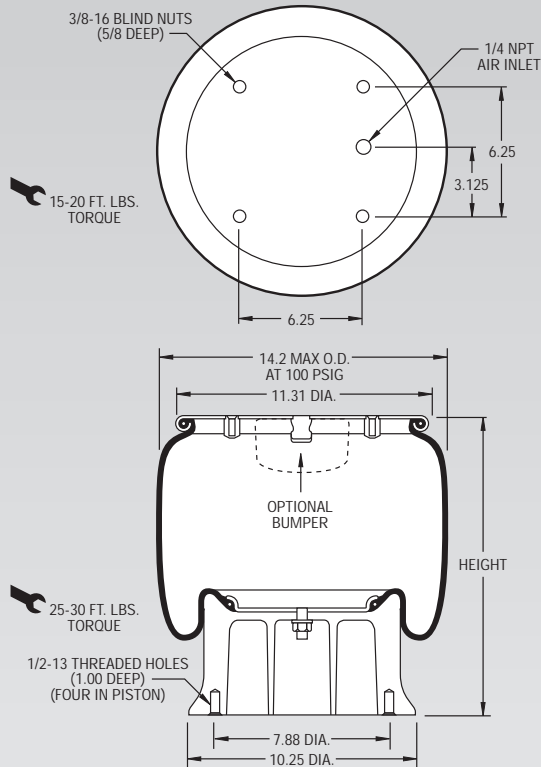

**NOTE:** Bellows will not compress properly with less than 20 PSIG internal pressure.

**NOTE:** A bead plate part is shown. This part is also available with a bead ring. Bolts are not included. See pages 8-10 for explanation.

Dynamic Characteristics at 15.0 in. Design Height (Required for Airmount isolator design only)				
Volume @ 100 PSIG = 1,252 in <sup>3</sup>			Natural Frequency	
Gage Pressure (PSIG)	Load (lbs.)	Spring Rate (lbs./in.)	CPM	HZ
40	3,476	532	73	1.22
60	5,264	777	72	1.20
80	7,052	982	70	1.17
100	8,898	1,227	69	1.15

CONSULT FIRESTONE BEFORE USING AS AIRMOUNT

RECOMMENDED AIRMOUNT DESIGN HEIGHT 15.0 INCHES

**Static Data**  
B0308

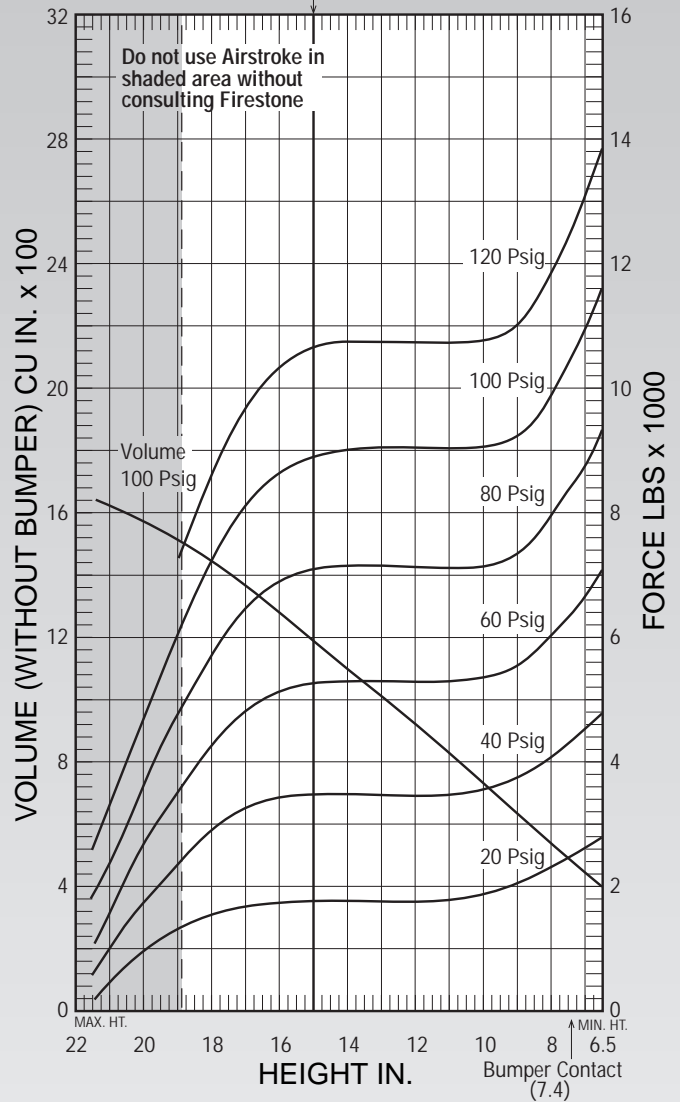

See page 12 for instructions on how to use chart.

Force Table (Use for Airstroke® actuator design)						
Assembly Height (in.)	Volume @ 100 PSIG (in <sup>3</sup> )	Pounds Force				
		@20 PSIG	@40 PSIG	@60 PSIG	@80 PSIG	@100 PSIG
18.50	1,480	1,398	2,605	3,859	5,194	6,645
16.50	1,328	1,705	3,309	4,952	6,624	8,350
14.50	1,155	1,760	3,482	5,293	7,095	8,964
12.50	969	1,760	3,482	5,297	7,101	8,984
10.50	778	1,760	3,482	5,297	7,101	8,984
8.50	591	2,126	3,876	5,748	7,597	9,515

# 1T19L-11 Firestone



Description		Assembly Order No.
Style 1T19L-11	Blind nuts, 1/4 NPT	WO1-358-9155
	Blind nuts, 1/4 NPT, bumper	WO1-358-9156
Two Ply Bellows	Blind nuts, 3/4 NPT	WO1-358-9153
	Blind nuts, 3/4 NPT, bumper	WO1-358-2132
	Button head steel bead ring	
	1 7/8 bolts, nuts, washers	WO1-358-9162
Assembly weight .....		22.6 lbs.

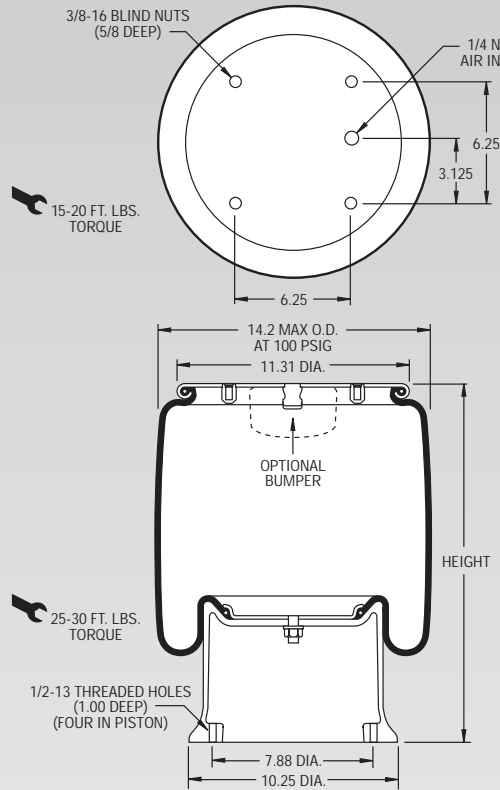

**NOTE:** Bellows will not compress properly with less than 20 PSIG internal pressure.

**NOTE:** A bead plate part is shown. This part is also available with a bead ring. Bolts are not included. See pages 8-10 for explanation.

Dynamic Characteristics at 18.0 in. Design Height (Required for Airmount isolator design only)				
Volume @ 100 PSIG = 1,252 in <sup>3</sup>			Natural Frequency	
Gage Pressure (PSIG)	Load (lbs.)	Spring Rate (lbs./in.)	CPM	HZ
40	3,411	428	67	1.12
60	5,151	602	64	1.07
80	6,911	765	63	1.05
100	8,711	927	61	1.02

CONSULT FIRESTONE BEFORE USING AS AIRMOUNT

RECOMMENDED AIRMOUNT DESIGN HEIGHT 18.0 INCHES

Static Data B0307

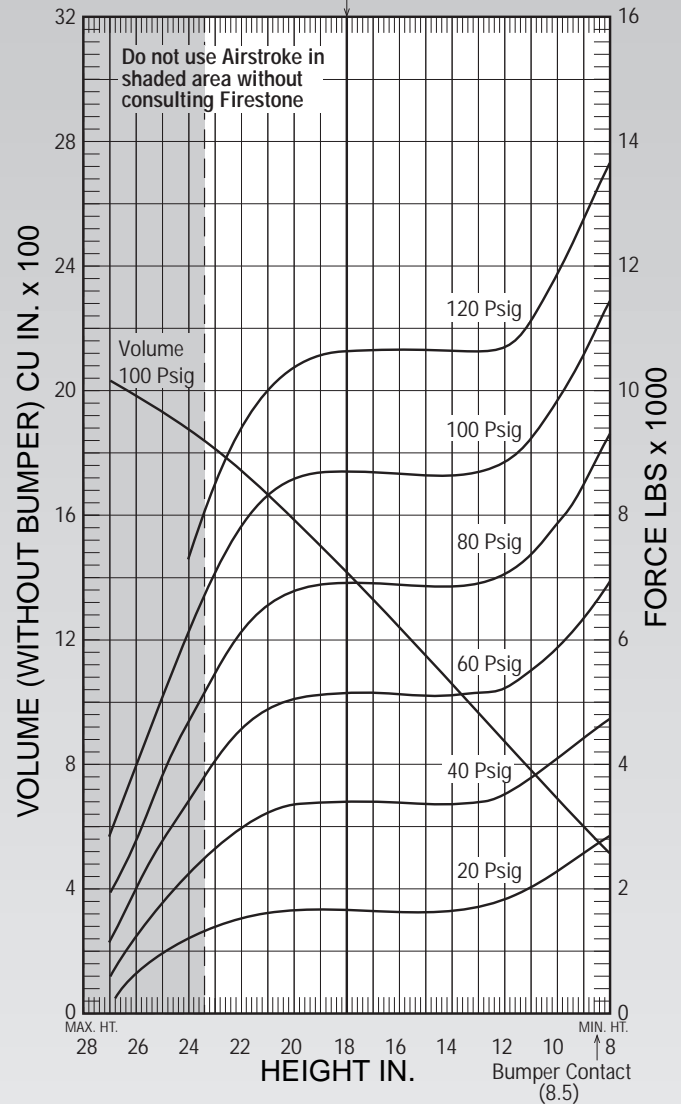

See page 12 for instructions on how to use chart.

Force Table (Use for Airstroke <sup>®</sup> actuator design)						
Assembly Height (in.)	Volume @ 100 PSIG (in <sup>3</sup> )	Pounds Force				
		@20 PSIG	@40 PSIG	@60 PSIG	@80 PSIG	@100 PSIG
20.0	1,597	1,650	3,341	5,068	6,843	8,619
18.0	1,427	1,650	3,411	5,151	6,911	8,711
16.0	1,247	1,650	3,411	5,151	6,911	8,711
14.0	1,060	1,650	3,411	5,151	6,911	8,711
12.0	872	1,830	3,510	5,278	7,101	8,903
10.0	688	2,283	4,100	5,960	7,946	9,911

# INDEX

## STYLE NUMBER TO PAGE NUMBER

TWO PLY STYLE NO.	HIGH STRENGTH STYLE NO.	SEE PAGE
----------------------	----------------------------	----------

### SINGLE CONVOLUTION

16		38
16-ST		39
131		40
110		41
116	117	42
116-1		43
115	124	44
19		45
19-.75		46
113	128	47
113-1	128-1	48
153-2		49
119		50
121		51
126		52
138-1.5		53
148-1	[148-1 is high strength]	54

### DOUBLE CONVOLUTION

25		55
255-1.5		56
224		57
26		58
20	202	59
20-2		60
22	210	61
22-1.5		62
21	205	63
21-2		64
233-2		65
28	201	66
203	218	67
29	207	68
200		69
215		70
248-2	[248-2 is high strength]	71

TWO PLY STYLE NO.	HIGH STRENGTH STYLE NO.	SEE PAGE
----------------------	----------------------------	----------

### TRIPLE CONVOLUTION

352		72
313	39	73
333		74
312	314	75
323	324	76
320	328	77
321		78
348-3	[348-3 is high strength]	79

### REVERSIBLE SLEEVE

1X84D-1		80
4001		81
7002		82
7010		83
7012		84
1T12E-3		85
1T14C-1		86
1T14C-3		87
1T14C-7	1T28F-8	88
1T15T-1		89
1T15S-6		90
1T15L-4		91
1T15M-0		92
1T15M-2		93
1T15M-4		94
1T15M-6		95
1T15M-9		96
1T19L-7		97
1T19L-11		98

### SHAPED SLEEVE

1M1A		34
1M1A-1		35
2M1A		36
2M2A		37

# AIRSTROKE<sup>®</sup> ACTUATOR DESIGN PARAMETER WORKSHEET

1. FORCE REQUIRED:

\_\_\_\_\_

2. STROKE REQUIRED:

\_\_\_\_\_

3. AVAILABLE AIR PRESSURE:

\_\_\_\_\_

4. ANGLE OF MOTION (PLEASE SKETCH):

6. ENVIRONMENTAL CONDITIONS:

\_\_\_\_\_

7. CYCLE RATE:

\_\_\_\_\_

8. RESPONSE TIME REQUIRED:

\_\_\_\_\_

SPECIAL REQUIREMENTS:

\_\_\_\_\_

\_\_\_\_\_

\_\_\_\_\_

\_\_\_\_\_

\_\_\_\_\_

\_\_\_\_\_

\_\_\_\_\_

\_\_\_\_\_

\_\_\_\_\_

5. LATERAL SPACE AVAILABLE FOR  
AIRSTROKE ACTUATOR(S):

\_\_\_\_\_

DATE \_\_\_\_\_

PLEASE SKETCH WITH DIMENSIONS

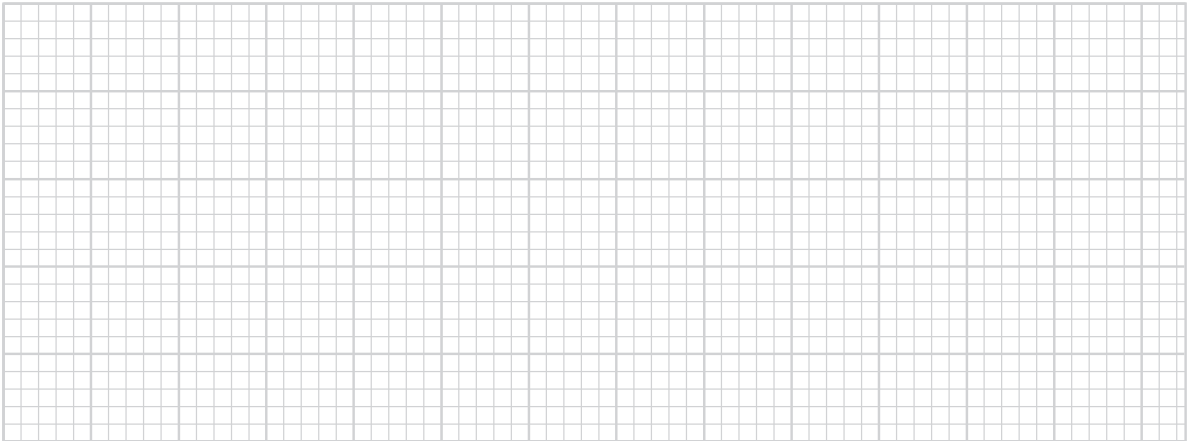

REMARKS

\_\_\_\_\_

\_\_\_\_\_

\_\_\_\_\_

\_\_\_\_\_

NAME \_\_\_\_\_

COMPANY \_\_\_\_\_

ADDRESS \_\_\_\_\_

CITY/COUNTRY/CODE \_\_\_\_\_

TELEPHONE \_\_\_\_\_

Please return to your local stocking distributor, or send directly to:  
Firestone Industrial Products Company, 12650 Hamilton Crossing Blvd, Carmel, IN 46032 U.S.A.  
Phone: 1-800-888-0650

# AIRMOUNT<sup>®</sup> ISOLATOR DESIGN PARAMETER WORKSHEET

**FOR VIBRATION ISOLATION**

- A) TO PREVENT OUTGOING VIBRATION TRANSMISSION (INTO THE SURROUNDING AREA), OR
- B) FOR ISOLATING DELICATE EQUIPMENT FROM INCOMING VIBRATIONS, PLEASE COMPLETE THE FOLLOWING:

1. DESCRIPTION OF EQUIPMENT:

\_\_\_\_\_

\_\_\_\_\_

\_\_\_\_\_

2. TYPE OF DISTURBANCE TO BE ISOLATED (FORCED FREQUENCY OF VIBRATION):

\_\_\_\_\_

3. MAXIMUM WEIGHT (lbs.) \_\_\_\_\_

4. WEIGHT DISTRIBUTION (PLEASE SKETCH ON GRAPH).

5. DESIRED NUMBER OF MOUNTING POINTS: \_\_\_\_\_

6. POSITION OF MOUNTING POINTS (PLEASE SKETCH ON GRAPH).

7. SPACE (DIAMETER) AVAILABLE FOR AIRMOUNT ISOLATORS (inches): \_\_\_\_\_

8. AIR PRESSURE AVAILABLE: \_\_\_\_\_

9. DIMENSIONS: HEIGHT (inches) \_\_\_\_\_

LENGTH (inches) \_\_\_\_\_

WIDTH (inches) \_\_\_\_\_

10. POSITION OF CENTER OF GRAVITY (C.G.,  $\odot$ , mm UP FROM BASE) \_\_\_\_\_

11. DISTURBING FREQUENCY ( $f_f$ )

a) FOR A) ABOVE, MACHINE SPEED, (rpm) \_\_\_\_\_

b) FOR B) ABOVE, FREQUENCY OF INCOMING VIBRATION ( $H_z$ ) \_\_\_\_\_

12. PERCENT ISOLATION DESIRED (%): \_\_\_\_\_

NAME \_\_\_\_\_

COMPANY \_\_\_\_\_

ADDRESS \_\_\_\_\_

CITY/ COUNTRY/CODE \_\_\_\_\_

PHONE \_\_\_\_\_

**FOR ISOLATING AN UNBALANCED MASS**

13. PLEASE COMPLETE 1 THROUGH 12, AND ALSO INCLUDE:

14. TYPE OF MOVING COMPONENTS (UNBALANCED MASS):

15. WEIGHT OF UNBALANCED MOVING MASS (lbs.): \_\_\_\_\_

16. RADIUS OF MOVEMENT (inches): \_\_\_\_\_

17. DIRECTION OF MOVEMENT (PLEASE SKETCH ON GRAPH).

**FOR SHOCK IMPACT ISOLATION**

18. PLEASE COMPLETE 1, AND ALSO INCLUDE:

19. WEIGHT OF MOVING OBJECT (lbs.): \_\_\_\_\_

20. SPEED OF MOVING OBJECT (in/sec): \_\_\_\_\_

21. DISTANCE OF FREE FALL (inches): \_\_\_\_\_

22. DESIRED STOPPING DISTANCE (inches): \_\_\_\_\_

23. SPACE (DIAMETER) AVAILABLE FOR SHOCK IMPACT ISOLATOR(S) (inches): \_\_\_\_\_

DATE \_\_\_\_\_

Please return to your local stocking distributor, or send directly to:  
Firestone Industrial Products Company, 12650 Hamilton Crossing Blvd, Carmel, IN 46032 U.S.A.  
Phone: 1-800-888-0650

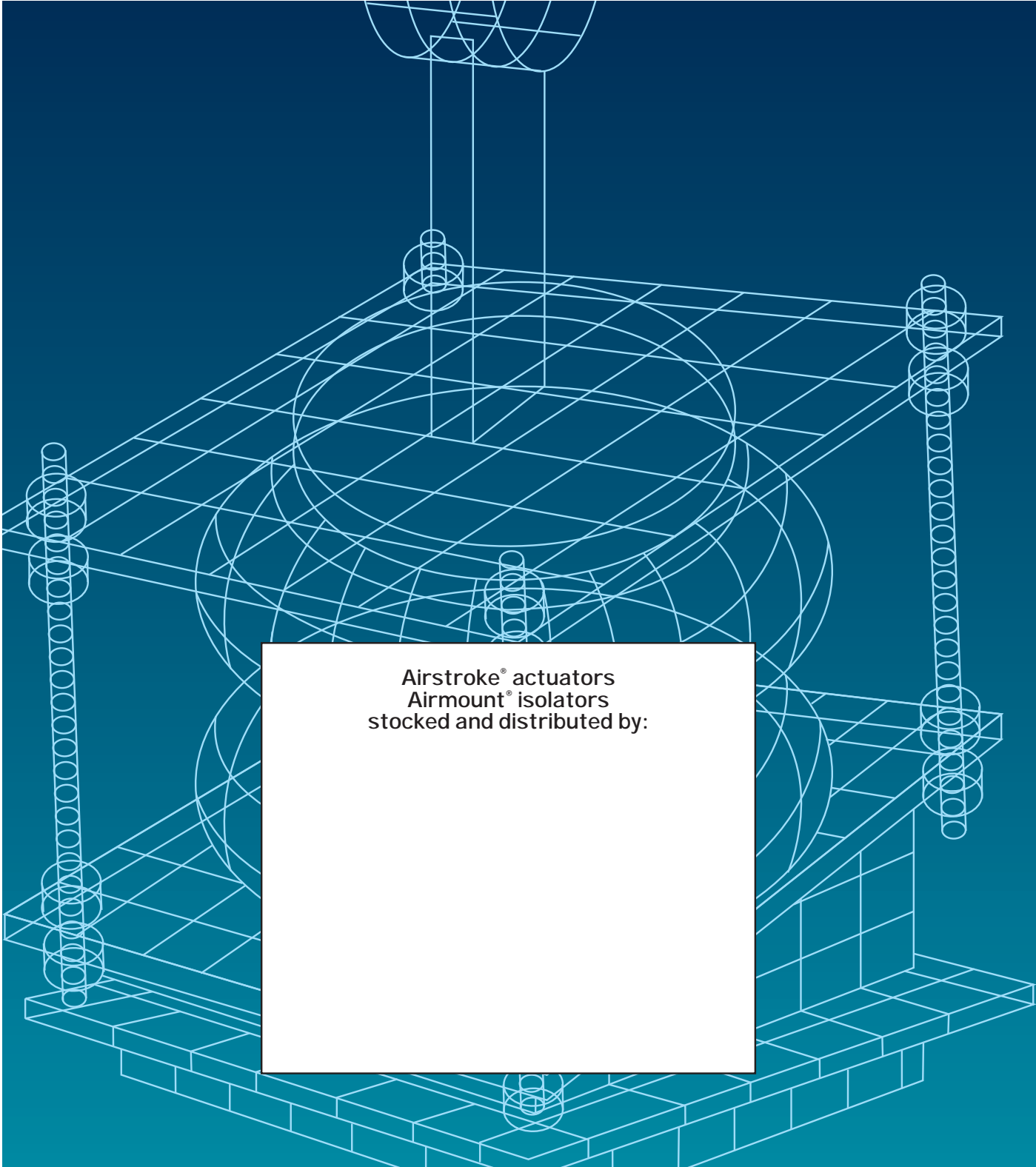

Airstroke® actuators  
Airmount® isolators  
stocked and distributed by:

**Firestone**

**World's Number 1**   
**Air Spring.**

FIRESTONE INDUSTRIAL PRODUCTS COMPANY

12650 Hamilton Crossing Blvd.  
Carmel, Indiana 46032  
1-800-888-0650

support@firestoneindustrial.com